



**SOLUTIONS FOR LIQUID NITROGEN PRE-COOLING
IN HELIUM REFRIGERATION CYCLES**

U. Wagner

Abstract

Pre-cooling of helium by means of liquid nitrogen is the oldest and one of the most common process features used in helium liquefiers and refrigerators. Its two principle tasks are to allow or increase the rate of pure liquefaction, and to permit the initial cool-down of large masses to about 80 K. Several arrangements for the pre-cooling process are possible depending on the desired application. Each arrangement has its proper advantages and drawbacks. The aim of this paper is to review the possible process solutions for liquid nitrogen pre-cooling and their particularities.

LHC Division

Presented at the Eighteenth International Cryogenic Engineering Conference (ICEC 18)
21-25 February 2000, Bombay Mumbai, India

Administrative Secretariat
LHC Division
CERN
CH - 1211 Geneva 23
Switzerland

Geneva, 26 July 2000

Solutions for Liquid Nitrogen Pre-cooling in Helium Refrigeration Cycles

Udo Wagner

LHC Division, CERN, 1211 Geneva 23, Switzerland

Pre-cooling of helium by means of liquid nitrogen is the oldest and one of the most common process features used in helium liquefiers and refrigerators. Its two principle tasks are to allow or increase the rate of pure liquefaction, and to permit the initial cool-down of large masses to about 80 K. Several arrangements for the pre-cooling process are possible depending on the desired application. Each arrangement has its proper advantages and drawbacks. The aim of this paper is to review the possible process solutions for liquid nitrogen pre-cooling and their particularities.

1 INTRODUCTION

Pre-cooling of helium with liquid nitrogen is a very common process feature. Each supplier of helium refrigerators has one or several standard solutions for the process arrangement and the nitrogen control. In fact only a limited number of solutions exists of how to integrate the liquid nitrogen pre-cooling into a helium refrigeration cycle. These different solutions have nevertheless each their proper advantage and draw back, and not all of them are equally adapted to the different tasks liquid nitrogen pre-cooling has to cover.

2 LIQUEFACTION DUTY AND COOL-DOWN DUTY

Two principle tasks for the cooling capacity supplied by liquid nitrogen down to approximately 80 K can be distinguished, liquefaction duty and cool-down duty, the requirements for which differ in several points.

During liquefaction the temperature range in which the cooling must be supplied remains constant, whereas during cool-down heat has to be withdrawn at continuously decreasing temperature. During cool-down the cooling capacity of the nitrogen available above the temperature of the helium returning from the load to be cooled is consequently lost.

The required capacity for cool-down is usually significantly higher than that necessary for liquefaction, which has to be taken into consideration for the design of the heat exchangers involved.

The flow imbalance between warm helium to be cooled and cold helium returning through the heat exchangers is limited for liquefaction, but maximum for cool-down duty. The temperature difference between the nitrogen and the helium can therefore become very large for cool-down duty, which again has to be taken into consideration for the design of the heat exchangers.

3 COMPARISON OF POSSIBLE SOLUTIONS

The different solutions for the process arrangement of the liquid nitrogen pre-cooling will be compared concerning:

- The adaptation to the required function;

- The danger of nitrogen freezing in the heat exchanger channels;
- The amount of liquid nitrogen necessary for cool-down operation.

3.1 Solutions with nitrogen and returning helium in the same heat exchanger

For all solutions where the returning low-pressure helium is passed through the same heat exchanger as the gaseous nitrogen, the risk of freezing of nitrogen is inherent. These solutions should therefore only be adopted if the probability of excessive amount of cold helium flowing through this heat exchanger is negligible. Three principle solutions that may be envisaged for the arrangement of heat exchangers, valves and process connections are shown in Figure 1.

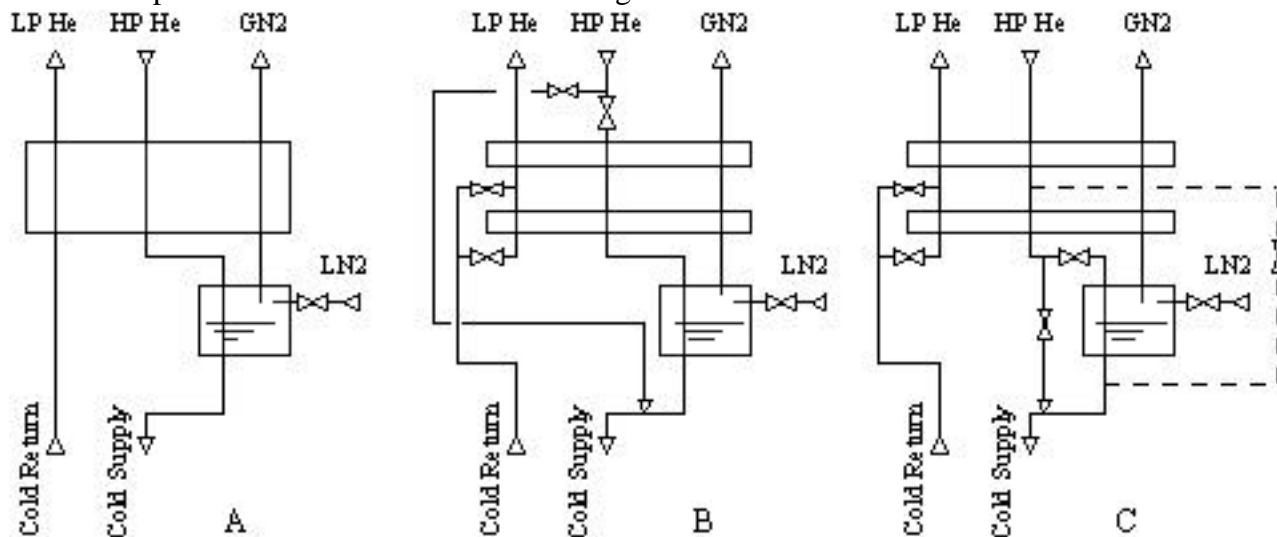

Figure 1 Solutions for the arrangement of nitrogen pre-cooling with the cold return helium in the same heat exchanger as the gaseous nitrogen

The arrangement given in Figure 1A is most common for liquefiers and is well suitable for continuous liquefaction duty. This arrangement is in general not adapted to cool-down operation, for which two major disadvantages can immediately be identified:

- Active control of the temperature of the cold helium supplied by the pre-cooler is difficult for the start of the cool-down. A badly adapted control may even destroy the heat exchanger at the warm end;
- The main heat exchanger will see high temperature differences around its cold end.

The addition of by-pass lines as indicated in the process arrangement in Figure 1B, improves the functionality for cool-down operation. This arrangement is fully adapted both to steady state liquefaction load as to continuous cool-down operation. It represents no problem as for the control of the helium supply temperature, which is achieved by mixing with warm helium. The temperature difference at the cold end of the main heat exchanger is lower than in the previous example.

Finally the by-pass for mixing the warm helium stream in order to achieve smooth temperature control can be located at a lower temperature level as shown in Figure 2C. It could either be connected to the intermediate heat exchanger level or just above the liquid nitrogen vaporiser. Energetically this is equivalent whereas the first solution allows for slightly lower temperature differences at the cold end of the main heat exchanger.

3.2 Solutions with nitrogen and returning helium in separate heat exchangers

In order to avoid with certainty the risk of freezing of nitrogen in the heat exchanger channels, the exchanger including the nitrogen channels has to be separated from that with channels for helium returning from the cold end of the installation. Two principle solutions that may be envisaged for the arrangement of heat exchangers, valves and process connections are shown in Figure 2.

Compared to the solutions with common exchangers for all streams, these arrangements allow selecting high efficient aluminium plate fin exchangers for the helium-to-helium part, in which the temperature differences will always be small. For the nitrogen exchangers a technology that is probably

less efficient but tolerant to high temperature difference can be selected. The maximum temperature difference in the nitrogen exchangers will on the other hand always be larger as for the solutions integrating all channels.

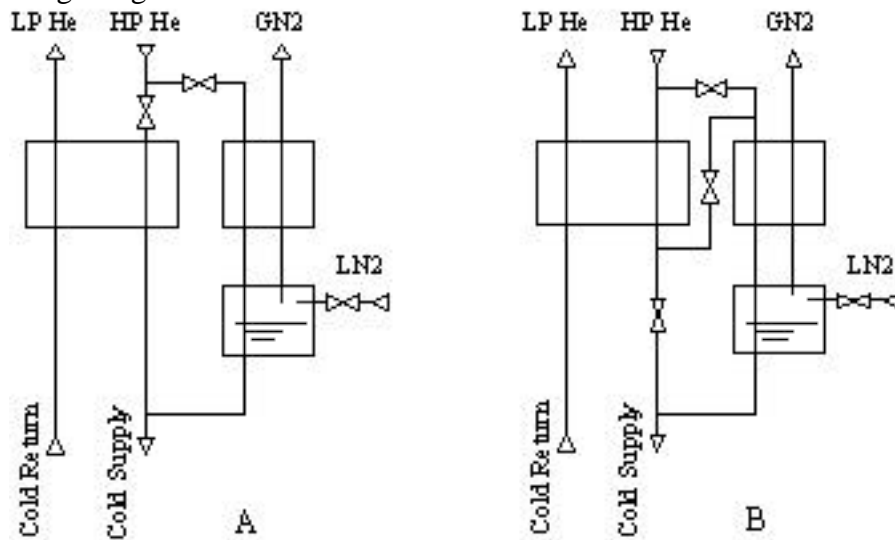

Figure 2 Solutions for the arrangement of nitrogen pre-cooling with the cold return helium in a separate heat exchanger as the gaseous nitrogen

The arrangement given in Figure 2A is perfectly adapted to pure liquefaction duty. For cool-down duty on the contrary it would require a continuously increasing helium mass flow through the nitrogen heat exchanger and consequently the cooling capacity from the returning helium could not be recovered. This arrangement is thus badly adapted to cool-down duty.

The addition of a by-pass line as shown in Figure 2B allows for cool-down operation. This arrangement is fully adapted both to steady state liquefaction load and to continuous cool-down operation. It represents no problem as for the control of the helium supply temperature, which is achieved by mixing of helium. The temperature difference at all headers of the helium-to-helium heat exchanger is small as this exchanger is always balanced.

A particularity of this arrangement, if used for cool-down operation, is that the nitrogen leaving the cold box will continuously decrease in temperature down to the temperature of saturated vapour. This must be considered when designing the nitrogen exhaust piping.

3.3 Thermal performance

The thermal performance for the different solutions is only analysed for cool down operation, as it is trivial for liquefaction duty. The arrangement in Figure 2A is therefore not considered. For the calculations, the following simplifications are used:

- Ideal heat exchange, i.e. down to zero temperature difference is assumed in order to neglect the efficiency effect of different heat exchanger solutions;
- The heat capacity of helium is considered constant;
- The nitrogen is assumed to evaporate at 80 K with a heat of evaporation of 200 J/g and with gaseous nitrogen having a constant heat capacity from vapour to ambient of 1.05 J/g.

It is evident that these simplifications, especially of the properties of state, lead to errors in the results. These errors are nevertheless sufficiently small to get qualitatively significant data. All data are plotted over the temperature of the cold returning helium and have as parameter the temperature difference between cold supply and return helium of 50 K, 75 K and 100 K. During cool-down, this temperature difference can of course only be maintained until the supply helium reaches the minimum temperature obtainable with the liquid-nitrogen pre-cooling.

The minimum amount of nitrogen necessary expressed in percent of the helium flow for cool-down, is shown in Figure 3. This performance can be realised with the arrangements as shown in Figures 1C and 2B. The nitrogen consumption for the arrangement given in Figure 1B is higher compared to these solutions until the supply temperature of the helium is at its minimum value. This results from the

mixing with warm gas instead of gas with constantly decreasing temperature. The relative mass flow is shown in Figure 4.

With decreasing helium return temperature a part of the nitrogen cooling capacity is lost. This loss results in decreasing temperatures at the warm end of the heat exchanger arrangement. For the solution with separated heat exchangers in Figure 2B this loss is expressed in a decreasing temperature of the gaseous nitrogen only. For the solutions with combined flow in the heat exchangers, this loss results in a decreasing temperature of the gaseous nitrogen and the returning helium. Assuming the same temperature for both streams, one can plot the outlet temperature at the warm end as function of the temperature for the returning helium, again with the temperature difference of the helium at the cold end as parameter.

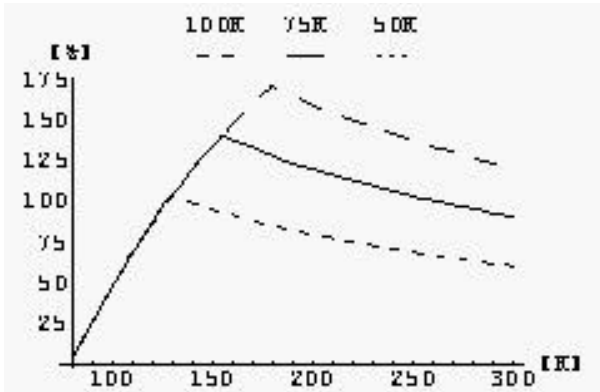

Figure 3 Minimum values for the relative nitrogen consumption versus cold helium return temperature

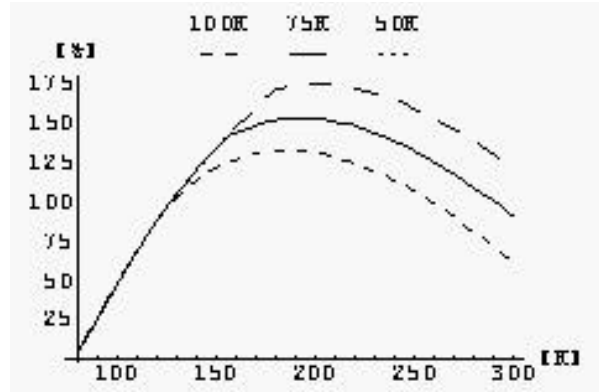

Figure 4 Relative nitrogen consumption versus cold helium return temperature as for solution of Figure 1B

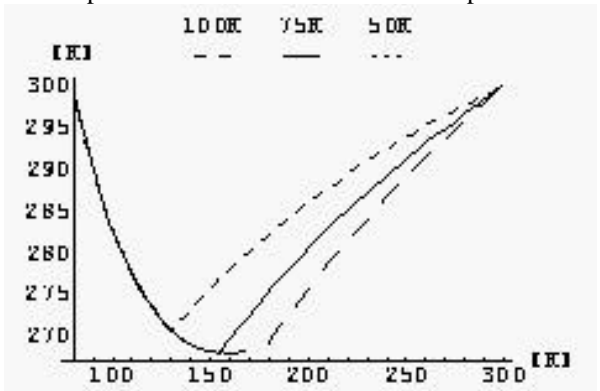

Figure 5 Warm end helium return temperature versus cold helium return temperature as for the solution for Figure 1C

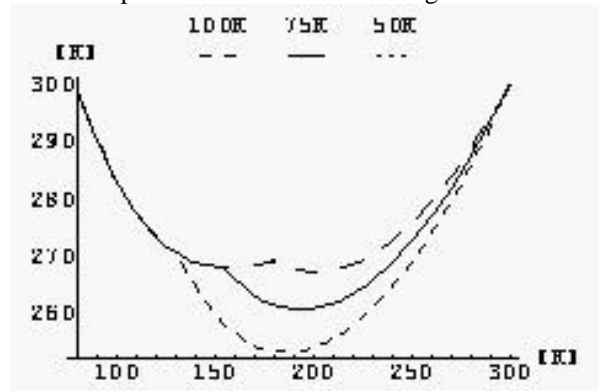

Figure 6 Warm end helium return temperature versus cold helium return temperature as for the solution for Figure 1B

Figure 5 shows the helium return temperature at the warm end as it results for the arrangement in Figure 1C and Figure 6 the one for the arrangement in Figure 1B. It is evident that the higher losses for the solution of Figure 1B that are already expressed in the nitrogen consumption result as well in lower return temperatures.

4 SUMMARY

Five principle solutions with their main characteristics for the process arrangement of the pre-cooling with liquid nitrogen have been presented. Pure liquefaction duty is of little issue and can be realised in a simple and straightforward way. For cool-down duty dedicated by-pass lines are required and the heat exchangers have to be designed for high temperature difference.

In order to decide on a specific solution to employ, one should also take into consideration the probability of excess flow of cold helium, the frequency of cool-down operation, the required temperature difference between supply and return helium, and the overall size of the refrigerator and the heat exchangers.