



Exergy Analysis of the Cryogenic Helium Distribution System for the Large Hadron Collider (LHC)

S. Claudet, Ph. Lebrun, L. Taviani & U. Wagner

(CERN)



Cryogenic Engineering Conference
International Cryogenic Materials Conference
Tucson, Arizona, USA
June 28 - July 2, 2009



Outline



- Introduction & Methodology
- From LHC Architecture & Distribution Scheme to
simplified flow diagrams for exergy calculation
- Exergy calculation results
- Exergy Analysis
- Conclusion





Introduction



Large scale (capacity) superconducting applications require distributing cooling power over long distances (high flow rates) with minimised temperature gradients for high thermodynamique efficiency

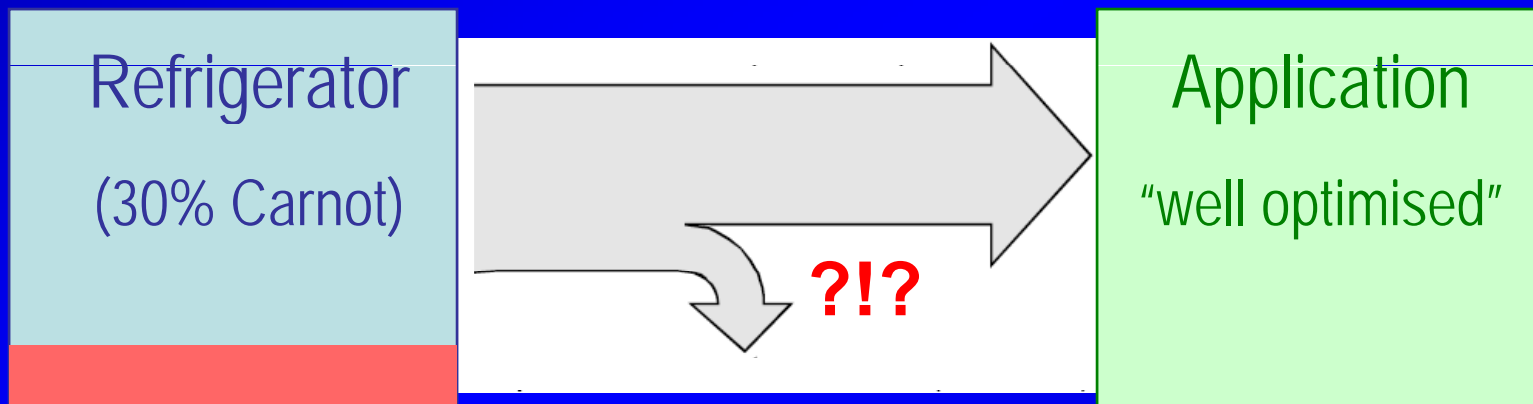

Exergy analysis (applied in the past for refrigeration plants) is proposed as a way to quantify distribution losses, with the potential to help technical arbitration among competing solutions





Methodology



Exergy "E" is a thermodynamic function of state

$T_0 = 290\text{K}$
(Cooling water temperature for heat rejection)

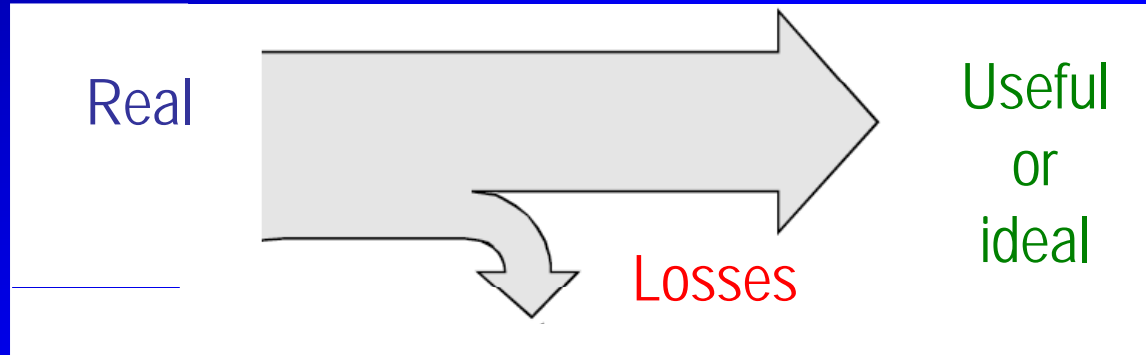

Definition of Exergy:

$$e = h - T_0 s$$

Process between two points:

$$\Delta E_{\text{real}} = m (\Delta h - T_0 \Delta s)$$

Useful Exergy:

$$\Delta E = Q (1 - T_0/T)$$

Non-isothermal cooling duties:

$$\Delta E = Q [1 - (T_0/T_2 - T_1) \ln T_2/T_1]$$

$$\text{Exergetic efficiency: } \eta = \Delta E_{\text{useful}} / \Delta E_{\text{real}}$$

Losses: heat inleaks, pressure drop, mixing, mismatch cooling temp. w.r.t temperature requirements





LHC Cryogenic Architecture

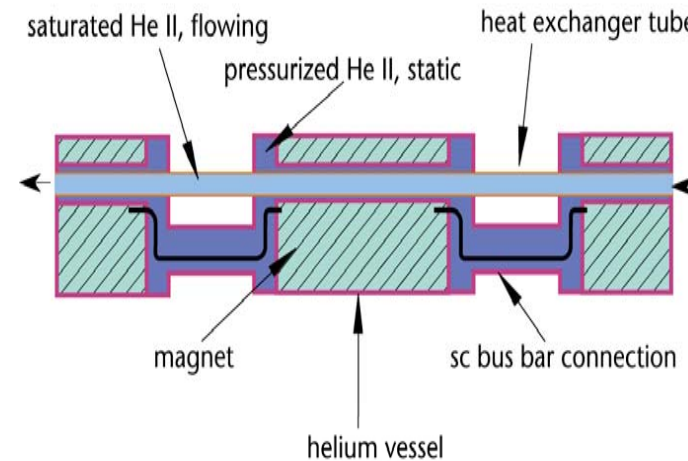
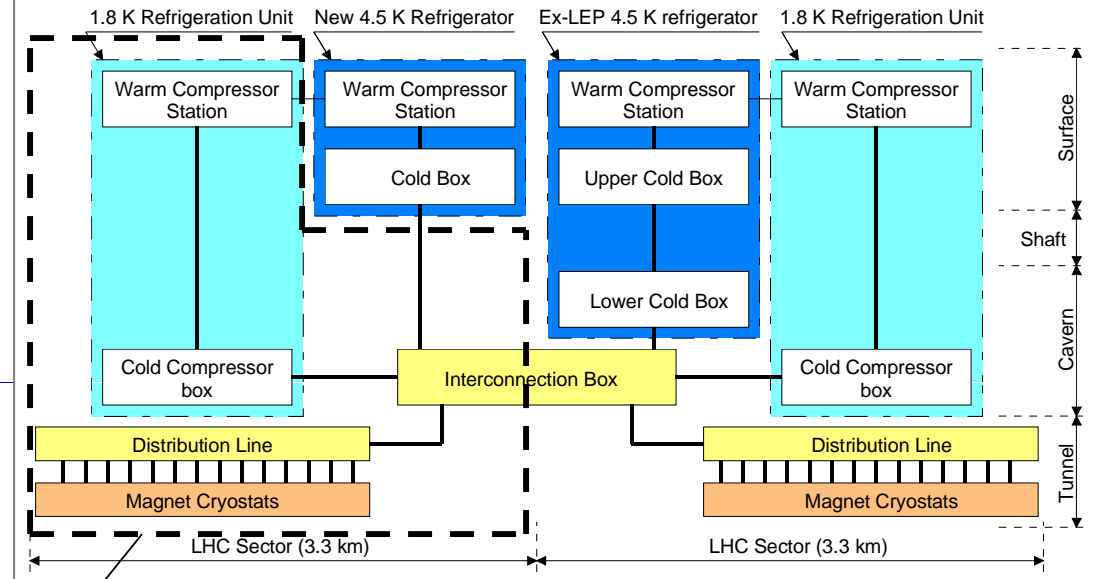
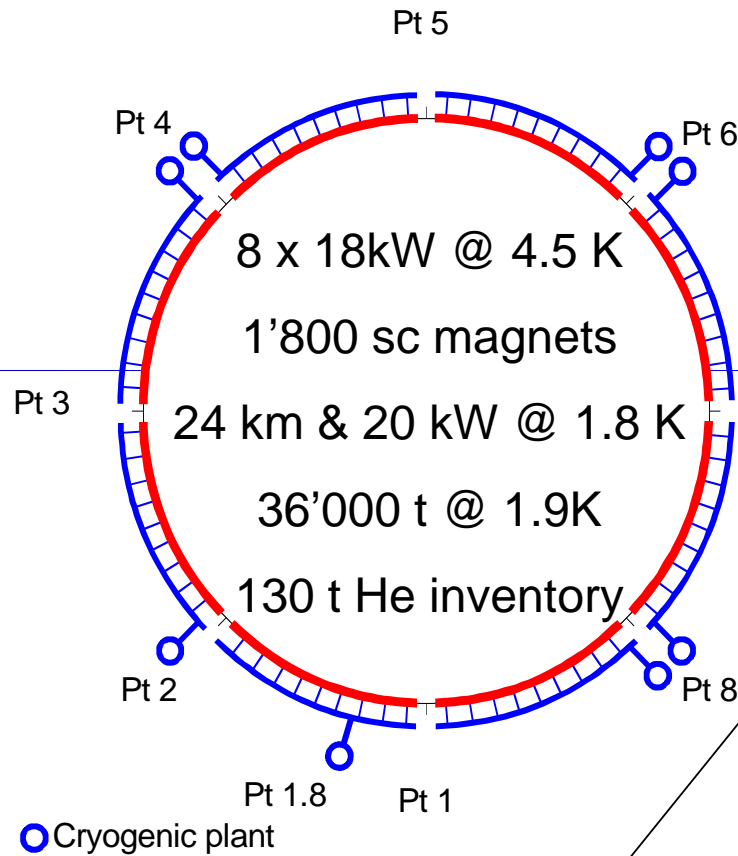

System to be studied





Distribution & Magnet Cooling

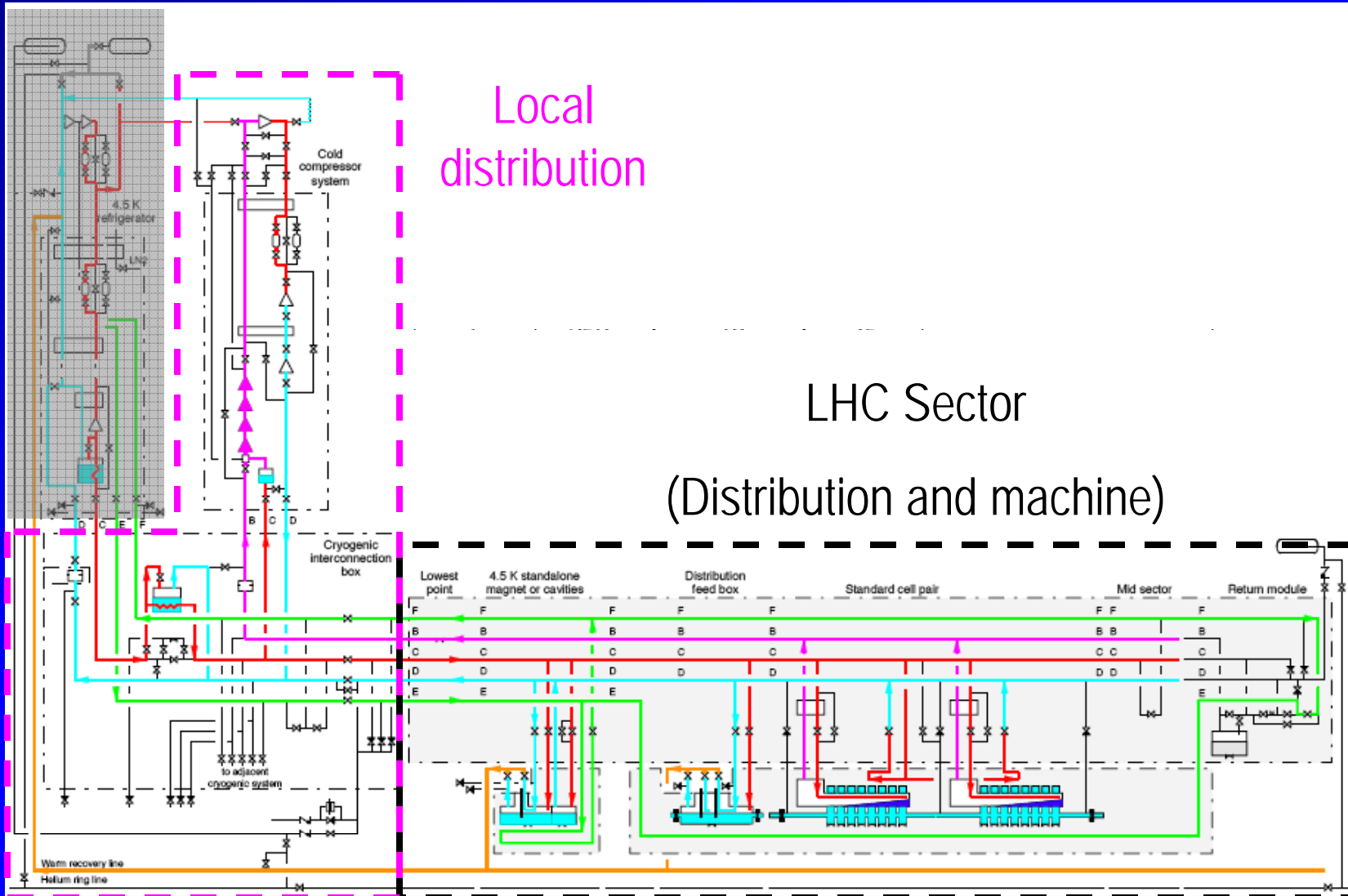



Part 1: LHC Local Distribution



Simplified flow diagram for helium distribution between the 4.5 K refrigerator and a LHC sector

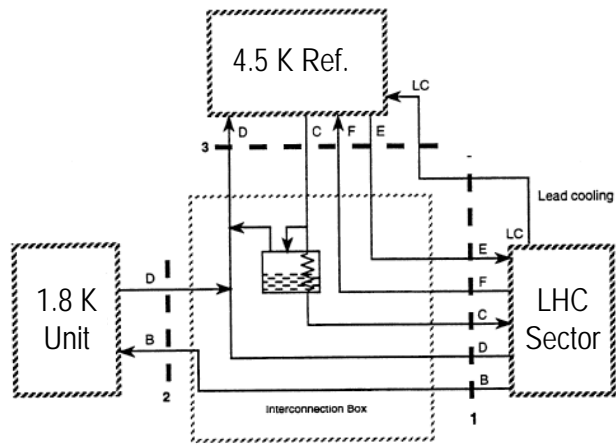

Each point defined by P, T, m', h, s, e calculated with HEPAK

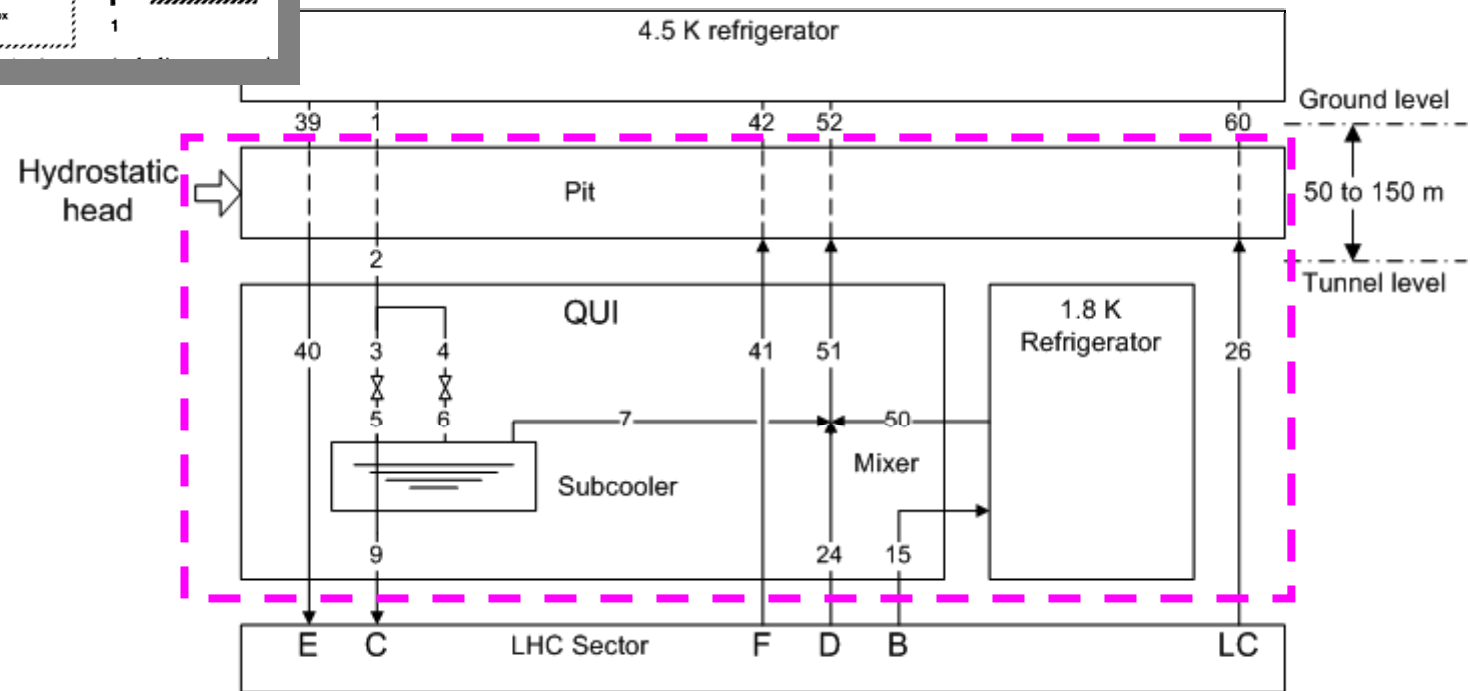



Part 2: LHC Sector



Simplified flow diagram a LHC sector

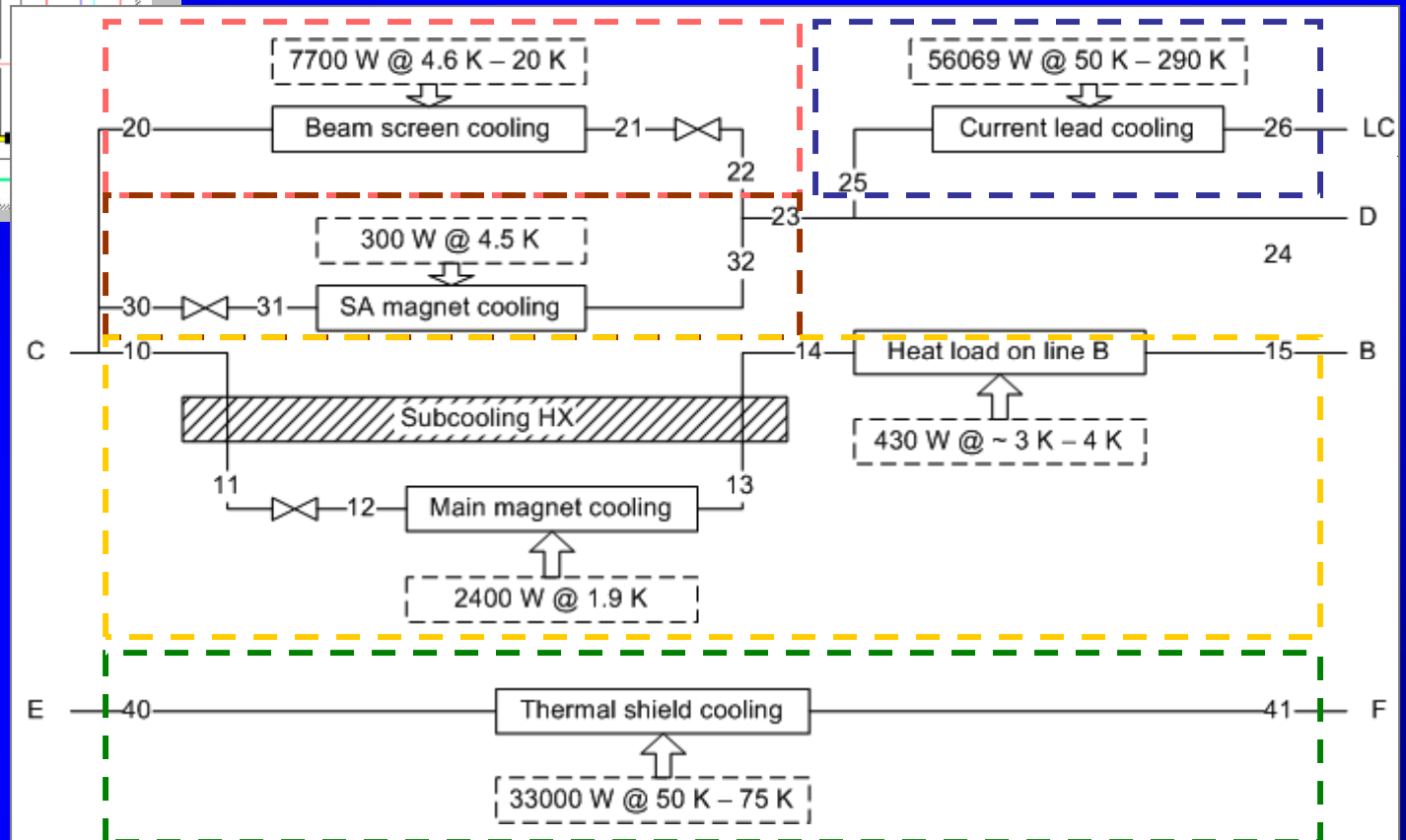
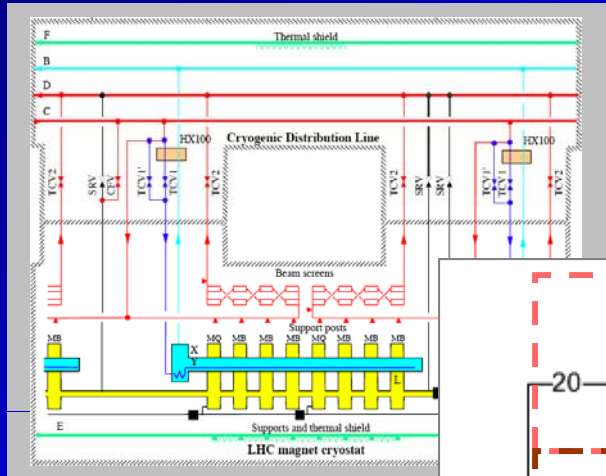

Each point defined by P , T , m'
 h , s , e calculated with HEPAK





Exergy Calculation Results



Part 1: Local distribution

| Process | ΔE [kW] |
|------------------------------|-----------------|
| Pit | 8.0 |
| Subcooling | 23.9 |
| Mixing (points 7, 24 and 50) | 25.8 |
| Total | 57.8 |

| Refrigerator | Process points | ΔE [kW] |
|--------------------|----------------------|-----------------|
| 4.5 K refrigerator | 1, 39, 42, 52 and 60 | 1103 |
| 1.8 K refrigerator | 15 and 50 | 34.1 |
| Total load | | 1137 |
| Total useful load | 95 % | 1079 |

Part 2: LHC Sector

| Cooling circuit | Process points | ΔE_{real} [kW] | ΔE_{useful} [kW] | η [%] |
|--------------------------------|-----------------|-------------------------------|---------------------------------|------------|
| Main magnets | 10 to 15 | 501 | 364 | 73 |
| Beam screens | 20 to 22 | 271 | 205 | 76 |
| Current leads | 25 to 26 | 122 | 63.0 | 52 |
| Stand-alone magnets and mixing | 22 and 30 to 23 | 40.1 | 19.0 | 47 |
| Thermal shields | 40 to 41 | 145 | 122 | 84 |
| Total | - | 1079 | 774 | 72 % |





LHC Distribution Exergy Flow Diagram

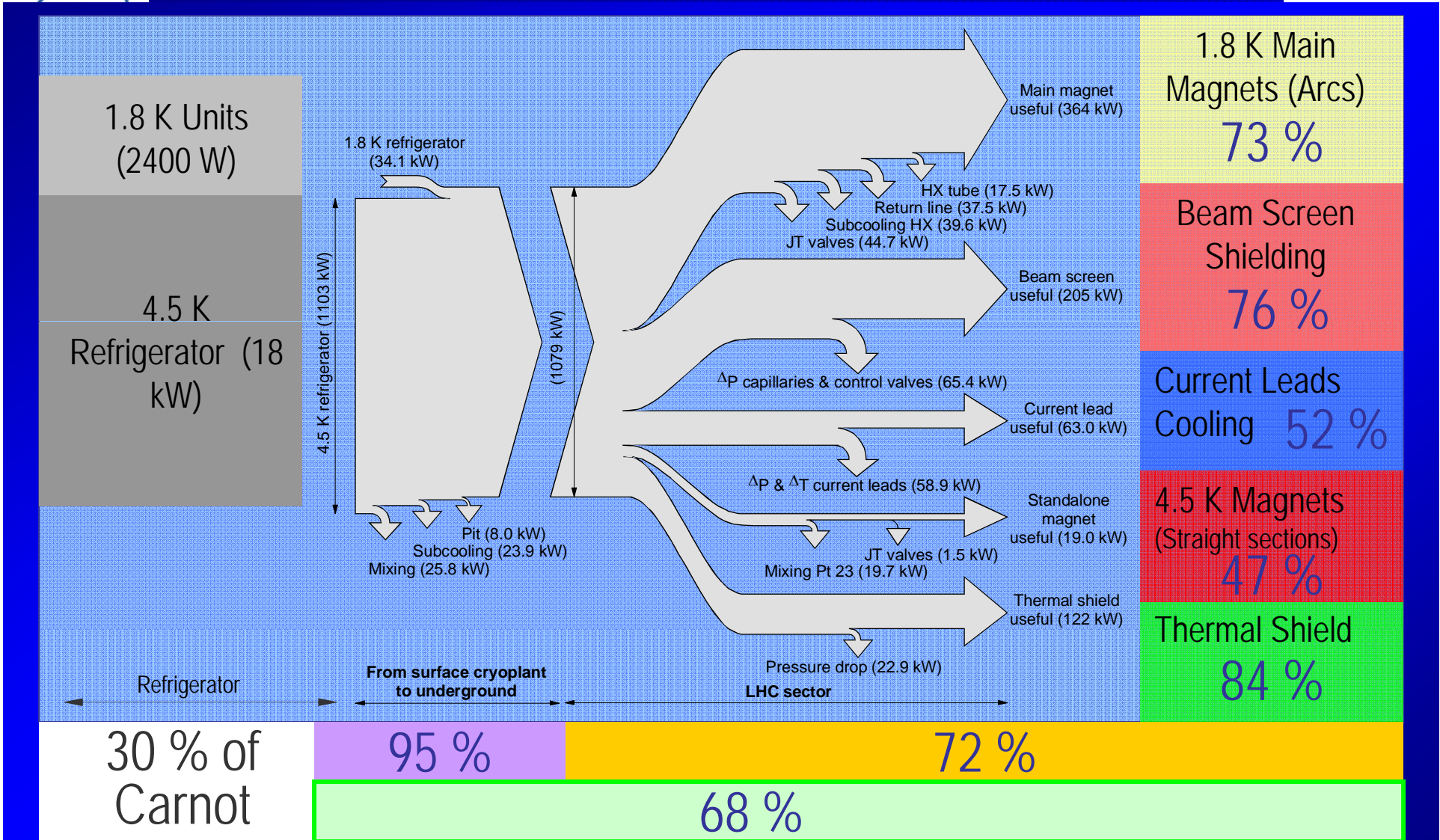



Analysis: Main Magnets Cooling



47.0 % of LHC Sector "Usefull Exergy"

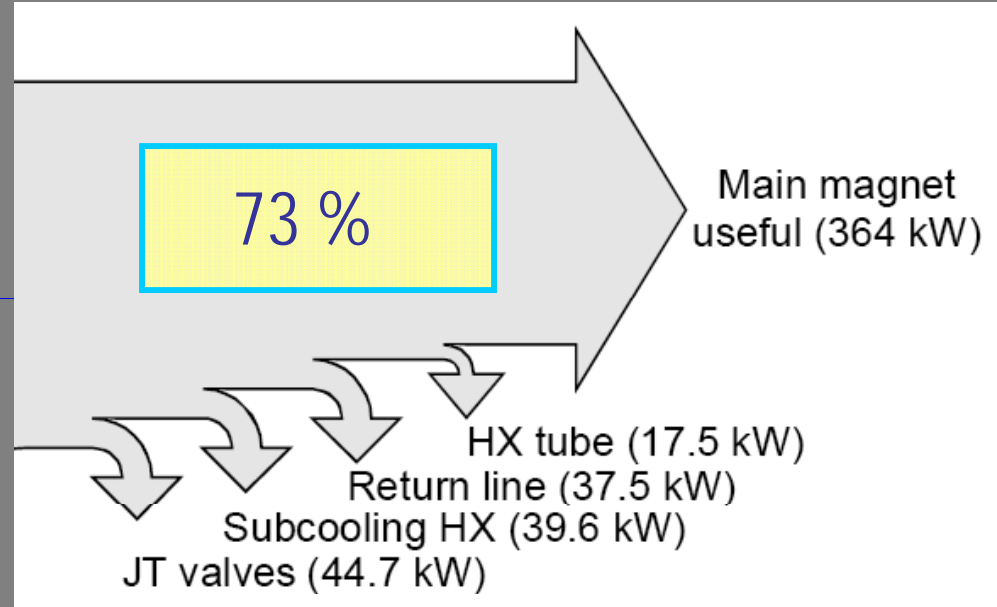
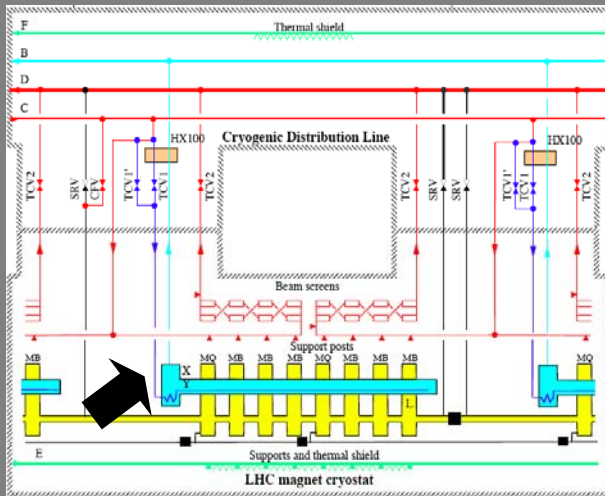
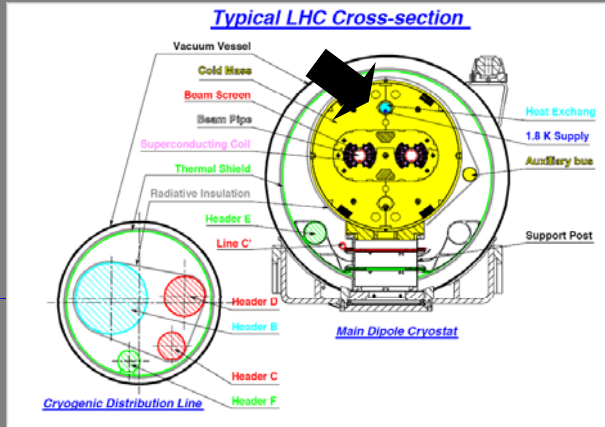

The exergy losses are very similar among the different sources of irreversibility





Analysis: Beam Screen Cooling



26.5 % of LHC Sector "Usefull Exergy"

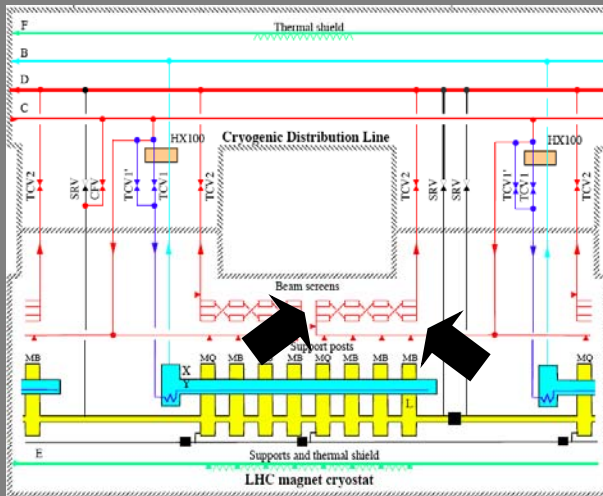
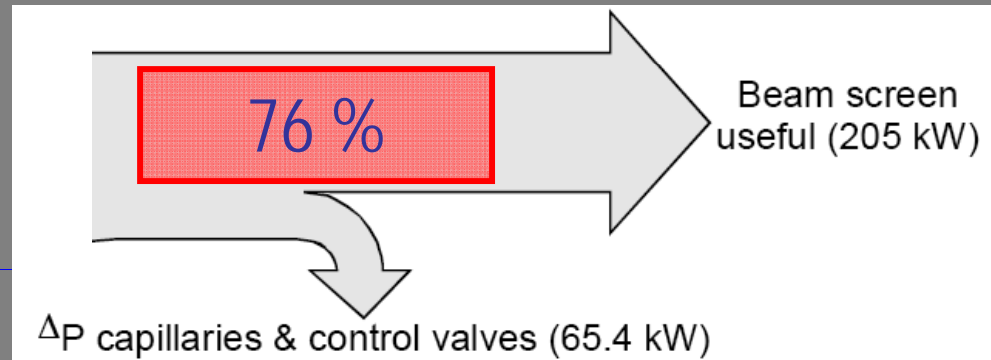
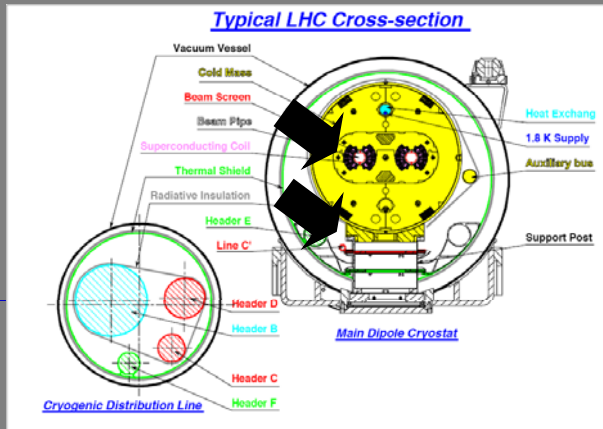

This is the price to pay for maintaining the thermodynamic state of the flowing helium well above the critical point, in order to limit the risk of instability.





Analysis: Thermal Shield Cooling



15.5 % of LHC Sector "Usefull Exergy"

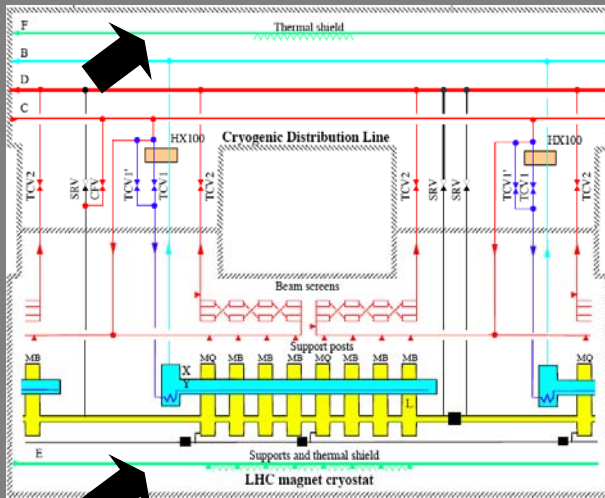
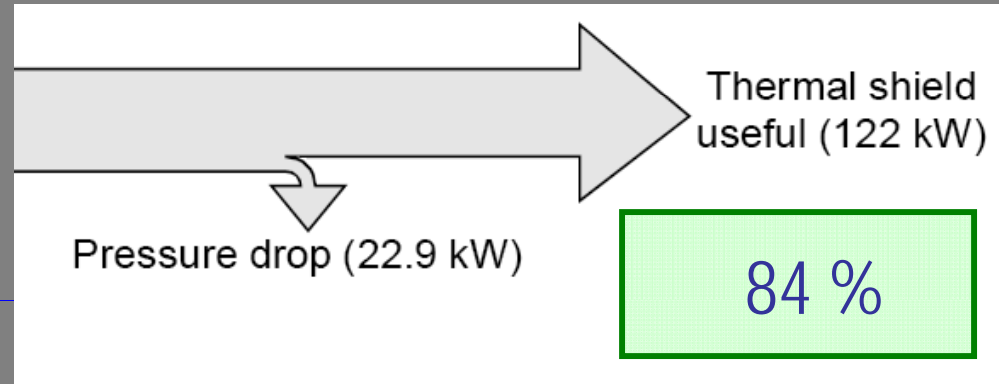
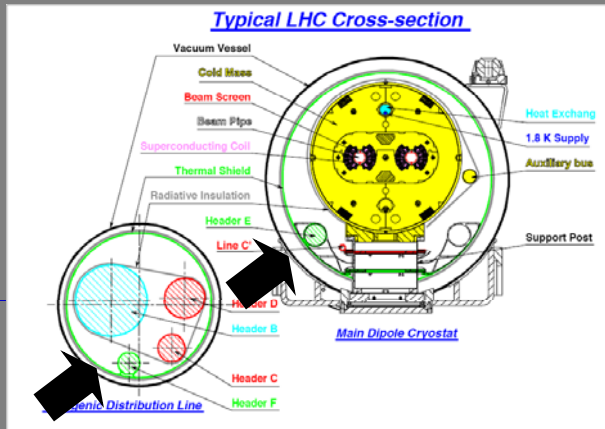

The piping diameter was defined to match ex-LEP refurbished plants, thus leaving room for optimisation in case the distribution system would have been newly designed





Analysis: Current Leads Cooling



8.2 % of LHC Sector "Usefull Exergy"

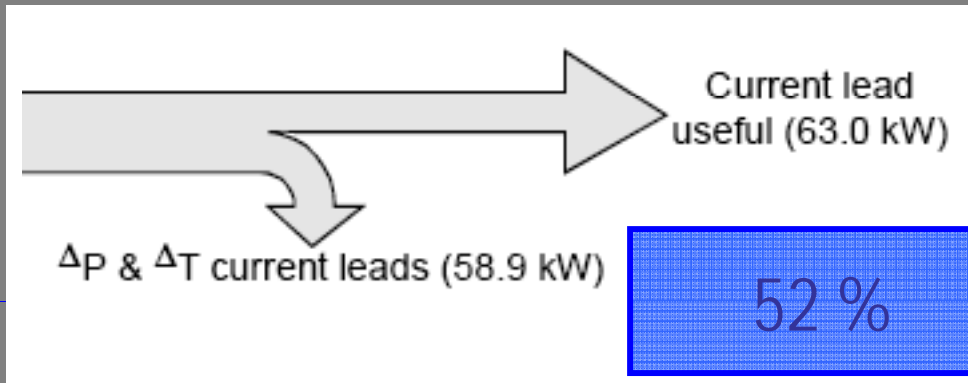

High temperature difference between cooling fluid and maximum tolerated by HTS part of the lead and high pressure drop in heat-exchanger (incl. valve)

(Conscious wish to have temperature margin for this new application)



Analysis: Stand-Alone Magnets



2.5 % of LHC Sector "Usefull Exergy"

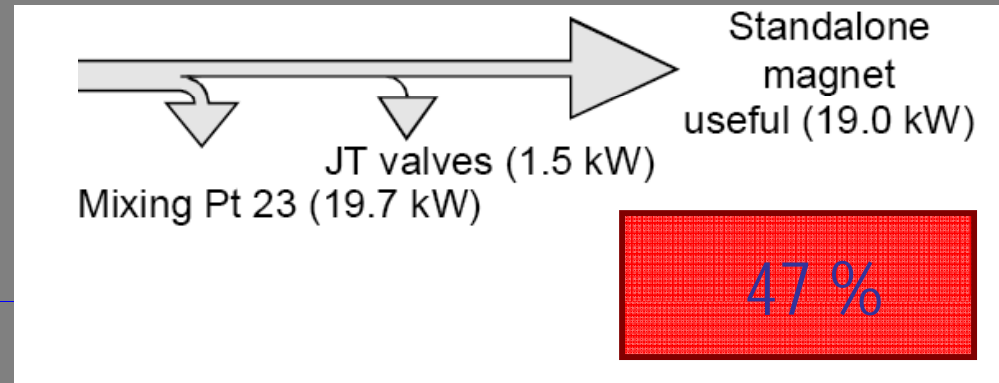
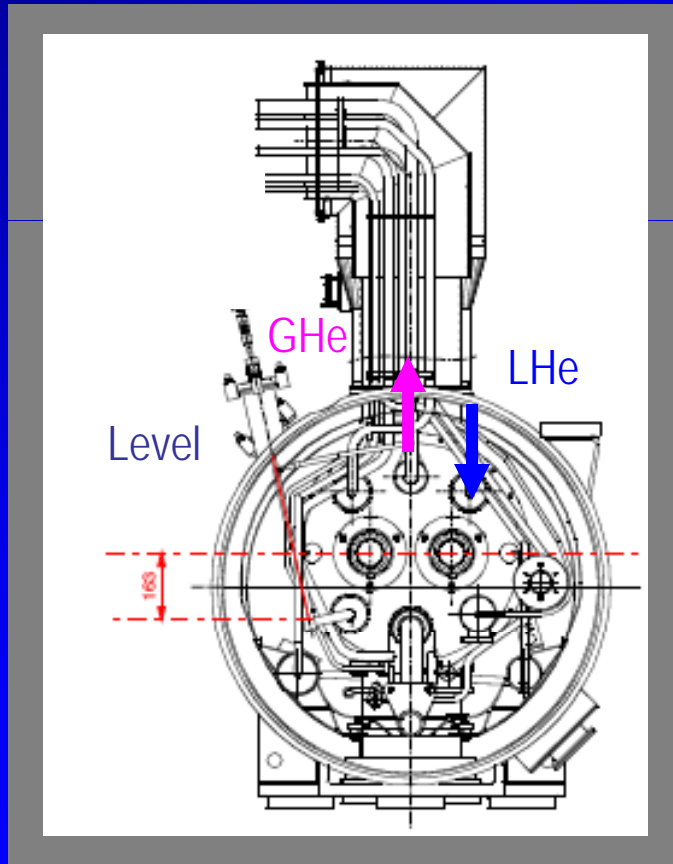

Considering "mixing" returned GHe vapors (4.5 K) with 20 K returned gas from the beam screen cooling loop (20 K) penalises the exergetic efficiency

Analysis: Local Distribution



7.5 % of LHC Sector "Usefull Exergy"

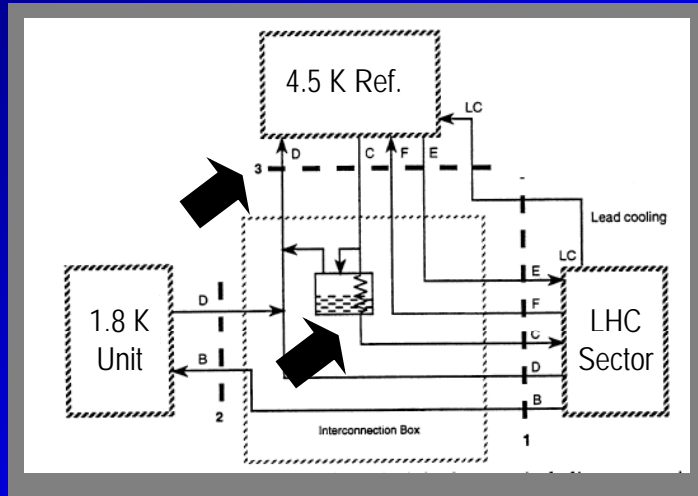

Vertical lines:

$$\Delta h = Q/m \pm g d$$

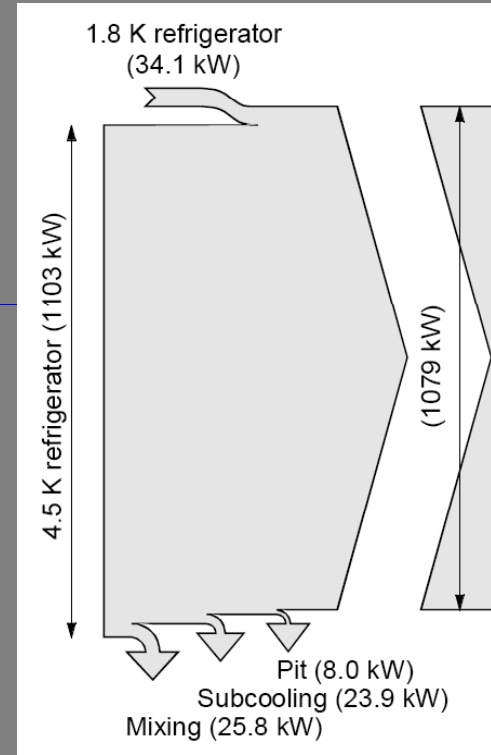

95 %

If we cannot do much against gravity, subcooling and part of mixing have been imposed mostly by the constraints to be able to cool sc cavities



From Simplified Schemes to Real Distribution ?



- Exergy analysis: good overview of the losses due to design choices
- However, not exact in every detail due to simplifications (simplified model - specification data - exergy analysis)
- A complete exergy analysis of a LHC sector would certainly be interesting in order to compare the real loads and losses along the sector to the design values, once at nominal operating conditions.
- Seems difficult as helium properties cannot be measured with sufficient precision using the installed industrial process instrumentation (mass flow values not measured at most locations along the sector)





Conclusion



- Thanks to the variety of its cooling duties, a 3.3km long sector of the LHC provides an interesting field for application of the exergetic analysis method to cryogenic distribution
- Cooling schemes and losses of very different nature can be compared in terms of their relative exergetic cost. The absolute value of the exergy gives almost directly the input power to the refrigeration system (within efficiency factor w.r.t Carnot)
- Overall efficiency of the LHC distribution system: **68 %** (no circulating pumps!)
(32 % of input power corresponds to about 1.3 MW !)
- We advocate application of the exergy analysis method to cryogenic systems as a powerful tool to render the design engineer second law conscious and allow him to optimize cryogenic distribution

