

SST-1 Cryogenic System (1.3 KW)

Different Components of HRL

- Compressor Skids
- Oil Removal System
- Online Purifier
- Cold Box
- Main Control Dewar (MCD)
- Integrated Flow Distribution & Control System (IFDCS)
- Current Leads (CL)
- Current Feeders system (CFS)

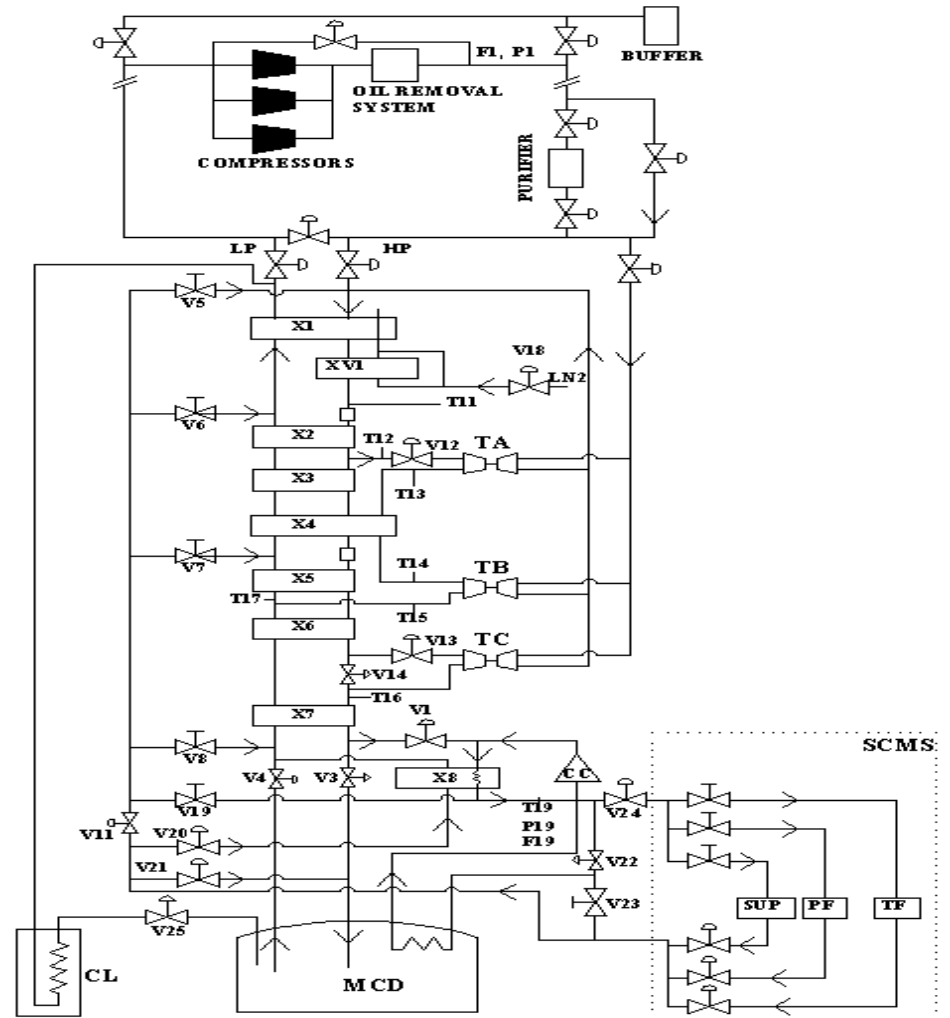
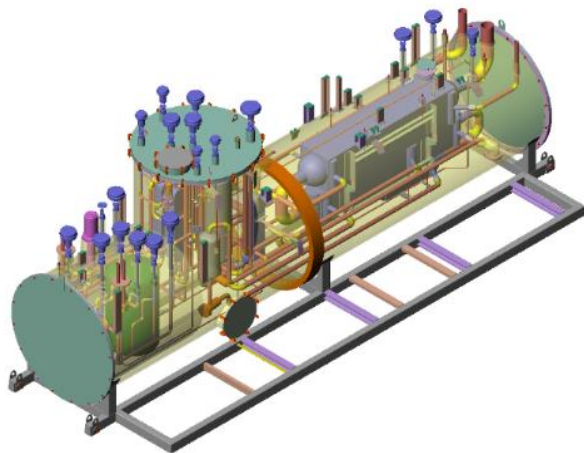

Important sub-systems of SST-1 Cryogenics System



Helium Screw Compressors Station



Oil Removal System

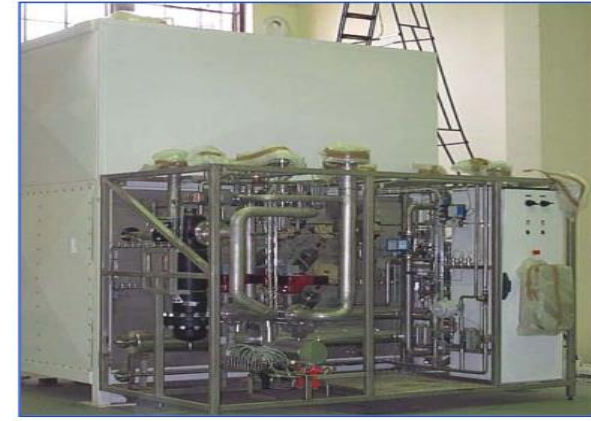

Main Purifier

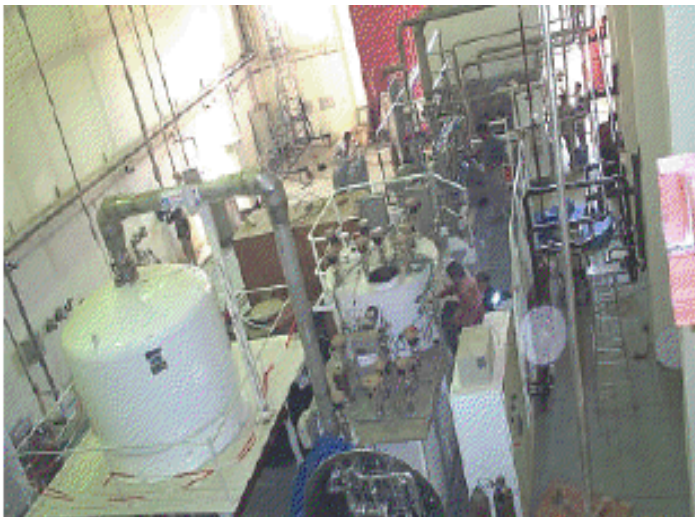

Helium cold-box and MCD (2500 L)



IFDC cold Helium distribution



LN2 Sub-cooler Dewar