

Axial and Centrifugal Compressors and Expander-compressors for Petroleum, Chemical and Gas Industry Services

API STANDARD 617
SEVENTH EDITION, JULY 2002



American
Petroleum
Institute

**Helping You
Get The Job
Done Right.SM**

11/19/2003 11:14:13 AM

Axial and Centrifugal Compressors and Expander-compressors for Petroleum, Chemical and Gas Industry Services

Downstream Segment

API STANDARD 617
SEVENTH EDITION, JULY 2002



**American
Petroleum
Institute**

**Helping You
Get The Job
Done Right.SM**

SPECIAL NOTES

API publications necessarily address problems of a general nature. With respect to particular circumstances, local, state, and federal laws and regulations should be reviewed.

API is not undertaking to meet the duties of employers, manufacturers, or suppliers to warn and properly train and equip their employees, and others exposed, concerning health and safety risks and precautions, nor undertaking their obligations under local, state, or federal laws.

Information concerning safety and health risks and proper precautions with respect to particular materials and conditions should be obtained from the employer, the manufacturer or supplier of that material, or the material safety data sheet.

Nothing contained in any API publication is to be construed as granting any right, by implication or otherwise, for the manufacture, sale, or use of any method, apparatus, or product covered by letters patent. Neither should anything contained in the publication be construed as insuring anyone against liability for infringement of letters patent.

Generally, API standards are reviewed and revised, reaffirmed, or withdrawn at least every five years. Sometimes a one-time extension of up to two years will be added to this review cycle. This publication will no longer be in effect five years after its publication date as an operative API standard or, where an extension has been granted, upon republication. Status of the publication can be ascertained from the API Downstream Segment [telephone (202) 682-8000]. A catalog of API publications and materials is published annually and updated quarterly by API, 1220 L Street, N.W., Washington, D.C. 20005, www.api.org.

This document was produced under API standardization procedures that ensure appropriate notification and participation in the developmental process and is designated as an API standard. Questions concerning the interpretation of the content of this standard or comments and questions concerning the procedures under which this standard was developed should be directed in writing to the standardization manager, American Petroleum Institute, 1220 L Street, N.W., Washington, D.C. 20005, standards@api.org. Requests for permission to reproduce or translate all or any part of the material published herein should also be addressed to the general manager.

API standards are published to facilitate the broad availability of proven, sound engineering and operating practices. These standards are not intended to obviate the need for applying sound engineering judgment regarding when and where these standards should be utilized. The formulation and publication of API standards is not intended in any way to inhibit anyone from using any other practices.

Any manufacturer marking equipment or materials in conformance with the marking requirements of an API standard is solely responsible for complying with all the applicable requirements of that standard. API does not represent, warrant, or guarantee that such products do in fact conform to the applicable API standard.

All rights reserved. No part of this work may be reproduced, stored in a retrieval system, or transmitted by any means, electronic, mechanical, photocopying, recording, or otherwise, without prior written permission from the publisher. Contact the Publisher, API Publishing Services, 1220 L Street, N.W., Washington, D.C. 20005.

Copyright © 2002 American Petroleum Institute

FOREWORD

API publications may be used by anyone desiring to do so. Every effort has been made by the Institute to assure the accuracy and reliability of the data contained in them; however, the Institute makes no representation, warranty, or guarantee in connection with this publication and hereby expressly disclaims any liability or responsibility for loss or damage resulting from its use or for the violation of any federal, state, or municipal regulation with which this publication may conflict.

Suggested revisions are invited and should be submitted to the standardization manager, American Petroleum Institute, 1220 L Street, N.W., Washington, D.C. 20005, standards@api.org.

CONTENTS

CHAPTER 1—GENERAL REQUIREMENTS

CHAPTER 2—CENTRIFUGAL AND AXIAL COMPRESSORS

CHAPTER 3—INTEGRALLY GEARED COMPRESSORS

CHAPTER 4—EXPANDER-COMPRESSORS

Chapter 1

General Requirements

01/19/2003 01:14:13 MST

CONTENTS

	Page
SECTION 1—GENERAL	1-1
1.1 Scope	1-1
1.2 Alternative Designs	1-1
1.3 Conflicting Requirements	1-1
1.4 Dimensions	1-1
1.5 Definition of Terms	1-1
1.6 Normative References	1-3
1.7 Statutory Requirements	1-4
1.8 Unit Responsibility	1-4
SECTION 2—BASIC DESIGN	1-4
2.1 General	1-4
2.2 Materials	1-5
2.3 Casings	1-7
2.4 Guide Vanes, Stators, and Stationary Internals	1-11
2.5 Rotating Elements	1-11
2.6 Dynamics	1-12
2.7 Bearings and Bearing Housings	1-25
2.8 Shaft End Seals	1-26
2.9 Gears	1-27
2.10 Lubrication and Sealing Systems	1-27
2.11 Nameplates and Rotation Arrows	1-27
2.12 Quality	1-28
SECTION 3—ACCESSORIES	1-28
3.1 Drivers	1-28
3.2 Couplings and Guards	1-28
3.3 Mounting Plates	1-29
3.4 Controls and Instrumentation	1-35
3.5 Piping and Appurtenances	1-35
3.6 Special Tools	1-36
SECTION 4—INSPECTION, TESTING, AND PREPARATION FOR SHIPMENT	1-36
4.1 General	1-36
4.2 Inspection	1-36
4.3 Testing	1-37
4.4 Preparation for Shipment	1-39
SECTION 5—VENDOR'S DATA	1-40
5.1 General	1-40
5.2 Proposals	1-40
5.3 Contract Data	1-42

ANNEX 1A	REFERENCE LIST OF U.S., ISO, AND INTERNATIONAL STANDARDS (NORMATIVE)	1-45
ANNEX 1B	PROCEDURE FOR THE DETERMINATION OF RESIDUAL UNBALANCE (NORMATIVE)	1-49
ANNEX 1C	TYPICAL SHAFT END SEAL CROSS-SECTIONAL DRAWINGS (INFORMATIVE)	1-59
ANNEX 1D	TESTING OF GAS SEALS IN SEAL VENDOR'S SHOP (NORMATIVE)	1-67
ANNEX 1E	TYPICAL MATERIAL SPECIFICATIONS (INFORMATIVE)	1-69

Figures

1.2-1	Rotor Response Plot	1-13
1.2-2	Undamped Stiffness Map	1-13
1.2-3a	Typical Mode Shapes—Between-bearing and Overhung Units (SI)	1-16
1.2-3b	Typical Mode Shapes—Between-bearing and Overhung Units (U.S. Customary Units)	1-16
1.2-3c	Typical Mode Shapes—Integrally Geared Pinion Type Rotors	1-17
1.2-4	Typical Plot of Applied Cross-coupled Stiffness vs. Log Decrement	1-21
1.2-5	Level I Screening Criteria	1-21
1.3-1	Typical Mounting Plate Arrangement	1-30
1.3-2	Typical Mounting Plate Arrangement	1-31
1.3-3	Typical Mounting Plate Arrangement	1-32
1.3-4	Typical Mounting Plate Arrangement	1-33
1.B-1	(Blank) Residual Unbalance Worksheet	1-52
1.B-2	(Blank) Residual Unbalance Polar Plot Worksheet	1-53
1.B-3	Sample Residual Unbalance Worksheet for Left Plane	1-54
1.B-4	Sample Residual Unbalance Polar Plot Worksheet for Left Plane	1-55
1.B-5	Sample Residual Unbalance Worksheet for Right Plane	1-56
1.B-6	Sample Residual Unbalance Polar Plot Worksheet for Right Plane	1-57
1.C-1	Labyrinth Shaft Seal	1-60
1.C-2	Mechanical (Contact) Shaft Seal	1-61
1.C-3	Restrictive-ring Shaft Seal	1-62
1.C-4	Liquid-film Shaft Seal with Cylindrical Bushing	1-63
1.C-5	Liquid-film Shaft Seal with Pumping Brush	1-64
1.C-6	Single Gas Seal	1-65
1.C-7	Double Gas Seal	1-65
1.C-8	Tandem Gas Seal	1-66
1.C-9	Tandem Gas Seal with Labyrinth	1-66

Tables

1.2-1	Design Criteria and Specifications for Cooling Water Systems	1-4
1.2-2	Casting Factors	1-8
1.2-3	Maximum Severity of Defects in Castings	1-10
1.E-1	Typical Material Specifications for Major Component Parts	1-70

SECTION 1—GENERAL

1.1 SCOPE

This standard covers the minimum requirements for axial compressors, single-shaft and integrally geared process centrifugal compressors and expander-compressor for use in the petroleum, chemical, and gas industries services that handle air or gas.

This standard does not apply to fans (covered by API Std 673) or blowers that develop less than 34 kPa (5 psi) pressure rise above atmospheric pressure. This standard also does not apply to packaged, integrally-gear centrifugal plant and instrument air compressors, which are covered by API Std 672. Hot gas expanders over 300°C (570°F) are not covered in this standard.

1.1.1 This chapter contains information pertinent to all equipment covered by this standard. It is to be used in conjunction with the following chapters as applicable to the specific equipment covered:

Chapter 2—Centrifugal and Axial Compressors

Chapter 3—Integrally Geared Compressors

Chapter 4—Expander-compressors

Note: A bullet (●) at the beginning of a paragraph indicates that either a decision is required or further information is to be provided by the purchaser. This information should be indicated on the data sheets (see Annex A of Chapters 2, 3 and 4); otherwise, it should be stated in the quotation request (inquiry) or in the order.

1.2 ALTERNATIVE DESIGNS

The vendor may offer alternative designs.

All designs should comply with this standard. Any exceptions to the standard including, alternate design differences from this standard, shall be clearly stated in the proposal.

1.3 CONFLICTING REQUIREMENTS

In case of conflict between this standard and the inquiry, the inquiry shall govern. At the time of the order, the order shall govern.

1.4 DIMENSIONS

The SI system of units and dimensions are used in this standard. Any data or drawings related to equipment supplied to this standard shall use the SI system.

Alternate systems such as the U.S. Customary system may be used if specified.

1.4.1 Unit Conversion

The units in this document are SI prime and U.S. Customary secondary.

Note: The factors in Chapter 15 of the *API Manual of Petroleum Measurement Standards* were used to convert from U.S. Customary to SI units. The resulting exact SI units were then rounded off.

1.5 DEFINITION OF TERMS

Terms used in all chapters of this standard are defined in 1.5.1 through 1.5.54. Annexes 2C, 3C, and 4C on nomenclature are located in each subsequent chapter of this specification.

1.5.1 axially split: A joint that is parallel to the shaft centerline.

1.5.2 compressor or expander section: A series of compression or expansion stages between which there is no intercooling or reheating, or loss or gain in flow (i.e., no side streams, bypassing or injection), and whose rotational speeds are in fixed relationship (ratio) to each other.

1.5.3 compressor rated point: The intersection on the 100% speed curve corresponding to the highest capacity of any specified operating point.

Note: This is generally a derived point rather than an actual operating point (see Figure 2.1-1a for a graphical representation).

1.5.4 critical speed: A shaft rotational speed at which the rotor-bearing-support system is in a state of resonance.

1.5.5 design: A term that may be used by the equipment manufacturer to describe various parameters such as design power, design pressure, design temperature, or design speed.

Note: This terminology should be used only by the equipment designer and manufacturer and not in the purchaser's specifications.

1.5.6 flammable fluid: The definition of a flammable fluid is covered in detail in NFPA 30.

1.5.7 gear service factor (sf): The factor that is applied to the tooth pitting index and the bending stress number, depending upon the characteristics of the driver and the driven equipment, to account for differences in potential overload, shock load, and/or continuous oscillatory torque characteristics.

1.5.8 gear wheel (bullgear): The lowest speed rotor in a gearbox.

1.5.9 gearing: The pinion(s) and gear wheel combination(s). A gear mesh is a pinion and gear wheel that operates together. A gear wheel may mesh with more than one pinion, and therefore be part of more than one gear mesh.

1.5.10 hold down bolts (mounting bolts): Bolts holding the equipment to the mounting plate.

1.5.11 hydrodynamic bearings: Bearings that use the principles of hydrodynamic lubrication. The bearing surfaces

are oriented so that relative motion forms an oil wedge, or wedges, to support the load without shaft-to-bearing contact.

1.5.12 hysteresis or internal friction dampening causes a phase difference between the stress and strain in any material under cyclical load. This phase difference produces the characteristic hysteric loop on a stress-strain diagram and thus, a destabilizing dampening force.

1.5.13 informative element: A reference which is provided for information and is intended to assist in the understanding or use of the standard. Compliance with an informative element is not mandated.

Note: An annex may be informative or normative as indicated.

1.5.14 inlet volume flow: The flow rate expressed in volume flow units at the conditions of pressure, temperature, compressibility, and gas composition, including moisture, at the equipment inlet flange.

1.5.15 machine: The compressor or expander.

1.5.16 maximum allowable temperature: The maximum continuous temperature for which the manufacturer has designed the equipment (or any part to which the term is referred).

Note: The maximum allowable temperature is usually set by material considerations. This may be the material of the casing or a temperature limit imposed by a gasket or O-ring. The material strength i.e., yield point, or ultimate strength is temperature dependent. A component's stress level can depend on operating pressure. Thus, the margin between the strength limit of the material and the operating stresses depends on both the materials operating temperature and the components stress level. If the temperature is lowered, the materials strength increases and the stress level of the component may increase. This is the reason for associating the maximum allowable temperature to the maximum specified operating pressure.

1.5.17 maximum allowable working pressure: The maximum continuous pressure for which the manufacturer has designed the equipment (or any part to which the term is referred) when handling the specified fluid at the specified maximum operating temperature.

Note: Refer to maximum allowable temperature.

1.5.18 maximum continuous speed: The highest rotational speed (revolutions per min. [rpm]) at which the machine, as-built and tested, is capable of continuous operation. For compressors with variable speed drivers, this speed is 105% of the rated speed. For compressors driven by fixed speed electric motors, this speed is based on the synchronous speed of the motor (see Figure 2.1-1a).

1.5.19 maximum discharge pressure: The maximum suction pressure plus the maximum differential pressure the compressor is able to develop, when operating with the furnished impeller(s) and the fluid with the maximum specific

gravity or molecular weight at compressor surge at the trip speed.

1.5.20 maximum inlet suction pressure: The highest inlet pressure the equipment will be subject to in service.

1.5.21 maximum sealing pressure: The highest pressure the seals are required to seal during any specified static or operating conditions and during start-up and shutdown.

1.5.22 minimum allowable speed: The lowest speed (in rpm) at which the manufacturer's design will permit continuous operation.

1.5.23 minimum allowable temperature: The lowest temperature for which the manufacturer has designed the equipment (or any part to which the term is applied).

Note: The modifier CONTINUOUS has not been applied to this definition since brittle fracture can occur during a short time the component may be at the low temperature.

1.5.24 modular rotor: A rotor which is built up using stub shafts or similar devices, and held together by one or more through bolts (see Annex 2C).

1.5.25 normal operating condition: The condition at which usual operation is expected and optimum efficiency is desired. This condition is usually the point at which the vendor certifies that performance is within the tolerances stated in this standard.

1.5.26 normal speed: The speed corresponding to the requirements of the normal operating condition.

1.5.27 normally open and normally closed: Refer both to on-the-shelf state and to installed deenergized state of devices such as automatically controlled electrical switches and valves.

Note: The normal operating condition of such devices is not necessarily the same as the on-the-shelf condition.

1.5.28 normative element: A requirement of the standard.

1.5.29 observed tests and inspections: Those for which the purchaser shall be notified of the timing; however, the inspection or test shall be performed as scheduled, and if the purchaser or his representative is not present, the vendor shall proceed to the next step. (The purchaser should expect to be in the factory longer than for a witnessed test.)

1.5.30 operating stability: The operating range from the compressor rated point to surge at constant speed expressed as a percentage.

1.5.31 pinion(s): The high-speed rotor(s) in a gearbox.

1.5.32 predicted capacity limit: The maximum volume flow capacity at the end of curve line which defines the manu-

facturer's capability to reasonably predict performance. This may or may not be an actual choke limit.

1.5.33 pressure casing: The composite of all stationary pressure-containing parts of the unit, including all nozzles and other attached parts.

1.5.34 purchaser: The individual or organization that issues the order and specification to the vendor.

Note: The purchaser may be the owner of the plant in which the equipment is to be installed or the owner's appointed agent.

1.5.35 radially split: A joint that is perpendicular to the shaft centerline.

1.5.36 rated speed (also known as 100% speed): The highest rotational speed required to meet any of the specified operating conditions.

1.5.37 relief valve set pressure: The pressure at which a relief valve starts to lift.

1.5.38 remote: Refers to the location of a device when located away from the equipment or console, typically in a control room.

1.5.39 settling out pressure: The pressure of the compressor system when the compressor is shut down.

1.5.40 shaft end seal: The process gas seal on the end of the shaft which restricts leakage of process gas to the atmosphere.

1.5.41 shall: "Shall" indicates a requirement.

1.5.42 should: "Should" indicates a recommendation.

1.5.43 stability analysis: The determination of the natural frequencies and the corresponding logarithmic decrements of the rotor/support system using a complex eigenvalue analysis.

1.5.44 stall: The volume flow capacity below which an axial compressor becomes aerodynamically unstable. This is caused by blade drag due to non-optimum incidence angles.

1.5.45 standard volume flow: The flow rate expressed in volume flow units at standard conditions as follows:

ISO STANDARD (NORMAL) CONDITIONS

Flow: Normal Cubic meters per hour (Nm³/h)
Normal Cubic meters per min. (Nm³/min.)
Pressure: 1.013 bar absolute
Temperature: 0°C

U.S. CUSTOMARY STANDARD CONDITIONS

Flow: Standard cubic ft per min. (scfm)
Million standard cubic ft per day (mmscfd)
Pressure: 14.7 PSIA
Temperature: 60°F

1.5.46 surge: The volume flow capacity below which a centrifugal compressor becomes aerodynamically unstable.

1.5.47 synchronous tilt pad coefficients: Derived from the complex frequency dependent coefficients with the frequency equal to the rotational speed of the shaft.

1.5.48 tooth pitting index: A surface durability rating factor that is determined by the tangential load, pitch diameter, face width and gear ratio.

1.5.49 total indicated reading (TIR), (also known as total indicator runout): The difference between the maximum and minimum readings of a dial indicator or similar device, monitoring a face or cylindrical surface during one complete revolution of the monitored surface.

Note: For a perfectly cylindrical surface, the indicator reading gives an eccentricity equal to half the reading. For a perfectly flat face, the indicator reading gives an out-of-squareness equal to the reading. If the diameter in question is not perfectly cylindrical or flat, interpretation of the meaning of TIR is more complex and may represent ovality or lobing.

1.5.50 trip speed (in rpm): The speed at which the independent emergency overspeed device operates to shut down a variable-speed prime mover. For the purpose of this standard, the trip speed of alternating current electric motors, except variable frequency drives, is the speed (rpm) corresponding to the synchronous speed of the motor at maximum supply frequency.

1.5.51 turndown: The percentage of change in capacity (referred to rated capacity) between the rated capacity and the surge point capacity at the rated head when the unit is operating at rated suction temperature and gas composition.

1.5.52 unit responsibility: Refers to the responsibility for coordinating the technical aspects of the equipment and all auxiliary systems included in the scope of the order. The technical aspects to be considered include but are not limited to such factors as the power requirements, speed, rotation, general arrangement, couplings, dynamics, noise, lubrication, sealing system, material test reports, instrumentation, piping, conformance to specifications and testing of components.

1.5.53 vendor (also known as supplier): The agency that supplies the equipment.

1.5.54 witnessed tests and inspections: Those to which a hold shall be applied to the production schedule and that the inspection or test shall be carried out with the purchaser or his representative in attendance. For mechanical running or performance tests, this requires written notification of a successful preliminary test.

1.6 NORMATIVE REFERENCES

1.6.1 Referenced publications are listed in Annex 1A.

1.6.2 All referenced standards to the extent specified in the text, are normative.

1.6.3 “Notes” following a paragraph are informative.

1.6.4 The editions of the Annex 1A standards, codes, and specifications that are in effect at the time of publication of this standard shall, to the extent specified herein, form a part of this standard.

The applicability of changes in standards, codes, and specifications that occur after the inquiry shall be mutually agreed upon by the purchaser and the vendor.

- **1.6.5** The purchaser will specify whether equipment supplied to this standard shall comply with the applicable ISO

standards or applicable U.S. standards.

1.7 STATUTORY REQUIREMENTS

The purchaser and the vendor shall mutually determine the measures that must be taken to comply with any governmental codes, regulations, ordinances, or rules that are applicable to the equipment.

1.8 UNIT RESPONSIBILITY

The vendor who has unit responsibility shall assure that all subvendors comply with the requirements of this standard and all reference standards.

SECTION 2—BASIC DESIGN

2.1 GENERAL

2.1.1 Performance

2.1.1.1 The equipment shall be capable of operating at all specified conditions.

- **2.1.1.2** The purchaser will specify the conditions for the equipment’s normal operating point.

2.1.1.3 The compressor shall be designed to deliver normal head at the normal inlet volumetric flow without negative tolerance. The power at the normal operating point shall not exceed 104% of the predicted value.

Note 1: See the optional performance test criteria in each chapter for handling of excess head for constant speed drivers and specified process intermediate pressures.

Note 2: The purchaser may furnish mass flow which will then be converted to volumetric flow by the supplier.

2.1.1.4 Gas properties used shall be mutually agreed upon.

2.1.2 The equipment (including auxiliaries) covered by this standard shall be designed and constructed for a minimum service life of 20 years and at least 5 years of uninterrupted operation.

Note: It is recognized that this is a design criterion.

2.1.3 The vendor shall assume unit responsibility for all equipment and all auxiliary systems included in the scope of the order.

2.1.4 Equipment driven by induction motors shall be rated at the actual motor speed for the rated load condition.

2.1.5 Unless otherwise specified, cooling water systems shall be in accordance with 2.1.5.1 through 2.1.5.2.

2.1.5.1 A cooling water system or systems shall be designed for the following conditions:

Table 1.2-1—Design Criteria and Specifications for Cooling Water Systems

Water velocity over heat exchange surfaces	1203.5 m/s – 2.5 m/s	5 ft/s – 8 ft/s
Maximum allowable working pressure (MAWP)	7.0 bar (Note)	100 psig
Test pressure (1.5 MAWP)	10.5 bar	150 psig
Maximum pressure drop	1 bar	15 psi
Maximum inlet temperature	30°C	90°F
Maximum outlet temperature	50°C	120°F
Maximum temperature rise	20 K	30°F
Minimum temperature rise	10 K	20°F
Water-side fouling factor	0.35 m ² K/kW	0.002 hr-ft ² -°F/Btu
Corrosion allowance for carbon steel shells	3 mm	1/8 in.

Note: Gauge pressure.

The vendor shall notify the purchaser if the criteria for minimum temperature rise and velocity over heat exchange surfaces result in a conflict. The criterion for velocity over heat exchange surfaces is intended to minimize water-side fouling; the criterion for minimum temperature rise is intended to minimize the use of cooling water. If such a conflict exists, the purchaser will approve the final selection.

2.1.5.2 Provision shall be made for complete venting and draining of the system or systems.

2.1.6 The arrangement of the equipment, including piping and auxiliaries, shall be developed jointly by the purchaser and the vendor at or before the coordination meeting.

Note: The arrangement should consider adequate clearance areas and safe access for operation and maintenance.

2.1.7 All equipment shall be designed to permit rapid and economical maintenance. Major parts such as casing components and bearing housings shall be designed and manufactured to ensure accurate alignment on reassembly. This may be accomplished by the use of shouldering, cylindrical dowels or keys.

- **2.1.8** The equipment including all auxiliaries shall be suitable for operation under the environmental conditions specified by the purchaser. These conditions shall include whether the installation is indoors (heated or unheated) or outdoors (with or without a roof), maximum and minimum temperatures, unusual humidity, and dusty or corrosive conditions.

- **2.1.9** Control of the sound pressure level (SPL) of all equipment furnished shall be a joint effort of the purchaser and the vendor having unit responsibility. The equipment furnished by the vendor shall conform to the maximum allowable sound pressure level specified. The vendor shall provide expected values for both maximum sound pressure and sound power level per octave band for the equipment.

- **2.1.10** The purchaser will advise the vendor in the inquiry of any specific requirements for liquid injection.

2.1.11 Equipment shall be designed to run without damage to the trip speed and the maximum allowable working pressure.

2.1.12 The equipment (machine, driver, and ancillary equipment) shall perform on the test stand and on their permanent foundation within the specified acceptance criteria. After installation, the performance of the combined units shall be the joint responsibility of the purchaser and the vendor who has unit responsibility.

- **2.1.13** Many factors (such as piping loads, alignment at operating conditions, supporting structure, handling during shipment, and handling and assembly at the site) may adversely affect site performance. To minimize the influence of these factors, the vendor shall, when requested, review and comment on the purchaser's piping and foundation drawings. When specified, the vendor's representative shall:

- a. Observe a check of the piping performed by parting the flanges.
- b. Check alignment at the operating temperature.
- c. Be present during the initial alignment check.

- **2.1.14** Motors, generators, electrical components, and electrical installations shall be suitable for the area classifica-

tion (class, group, and division) specified by the purchaser on the data sheets, and shall meet the requirements of NFPA 70, Articles 500 through 505 or IEC 60079-10 as applicable, as well as local codes specified and furnished by the purchaser.

2.1.15 Spare parts for the machine and all furnished auxiliaries shall meet all the criteria of this standard.

- **2.1.16** When specified, the machine or machines shall be suitable for field run on air. Performance parameters, including any required precautions, shall be mutually agreed upon by the purchaser and the vendor.

2.2 MATERIALS

2.2.1 General

2.2.1.1 Materials of construction shall be the manufacturer's standard for the specified operating conditions, except as required or prohibited by the data sheets or by this standard. Annex 1E lists material specifications that, when used with appropriate heat treatment or impact testing requirements, or both, are generally considered acceptable for major component parts. The metallurgy of all major components shall be clearly stated in the vendor's proposal. See 3.5 for requirements for auxiliary piping materials.

2.2.1.2 Materials shall be identified in the proposal with their applicable ASTM, AISI, ASME, or SAE numbers, including the material grade (see Annex 1E). When no such designation is available, the vendor's material specification, giving physical properties, chemical composition, and test requirements, shall be included in the proposal.

- **2.2.1.3** The purchaser will specify any corrosive agents (including trace quantities) present in the motive and process fluids in the site environment, including constituents that may cause stress corrosion cracking.

Note: Typical agents of concern are hydrogen sulfide, amines, chlorides, cyanide, fluoride, naphthenic acid and polythionic acid.

2.2.1.4 The vendor shall specify the optional tests and inspection procedures that may be necessary to ensure that materials are satisfactory for the service. Such tests and inspections shall be listed in the proposal.

Note: The purchaser may specify additional optional tests and inspections—especially for materials used for critical components or in critical services.

2.2.1.5 Low-carbon steels can be notch sensitive and susceptible to brittle fracture at ambient or lower temperatures. Therefore, only fully killed, normalized steels made to fine-grain practice are acceptable for machine components. The use of steel made to a coarse austenitic grain size practice (e.g., ASTM A-515) is prohibited.

- **2.2.1.6** Materials exposed to a sour environment (wet H₂S) as defined by NACE MR0175 shall be in accordance with the

requirements of that standard. Ferrous materials not covered by NACE MR0175 shall not have a yield strength exceeding 620 N/mm² (90,000 psi), nor a hardness exceeding Rockwell C 22. Components that are fabricated by welding shall be postweld heat treated, if required, so that both the welds and heat-affected zones meet the yield strength and hardness requirements.

Note 1: It is the responsibility of the purchaser to determine the amount of wet H₂S that may be present, considering normal operation, start-up, shutdown, idle standby, upsets, or unusual operating conditions such as catalyst regeneration.

Note 2: In many applications, small amounts of H₂S are sufficient to require materials resistant to sulfide stress corrosion cracking. When there are trace quantities of wet H₂S known to be present or if there is any uncertainty about the amount of wet H₂S that may be present, the purchaser should consider requiring materials that are resistant to sulfide stress corrosion cracking.

Note 3: Shafts in compressors of between-bearing design may exceed the stated limits of yield strength and hardness because of requirements for higher strength at reduced shaft sections near couplings and because of the low levels of working stress in the portion of the shaft between bearings.

2.2.1.7 Austenitic stainless steel parts that are to be fabricated, hard faced, overlaid or repaired by welding, and that are exposed to conditions that may promote intergranular corrosion shall be made of low-carbon or stabilized grades.

Note: Overlays or hard surfaces that contain more than 0.10% carbon can sensitize both low-carbon and stabilized grades of austenitic stainless steel, unless a buffer layer that is not sensitive to intergranular corrosion is applied.

2.2.1.8 Austenitic steels shall not be used in services where stress-corrosion cracking is a possibility.

2.2.1.9 Materials that have a yield strength in excess of 827 Mpa (120,000 psi) or hardness in excess of Rockwell C 34 are prohibited for use in hydrogen gas service where the partial pressure of hydrogen exceeds 689 kPa (100 psi gauge) or the hydrogen concentration exceeds 90 molar percent at any pressure.

2.2.1.10 External parts that are subject to rotary or sliding motions (such as control linkage joints and adjusting mechanisms) shall be of corrosion-resistant materials suitable for the site environment.

2.2.1.11 Minor parts (such as nuts, springs, washers, gaskets, and keys) shall have corrosion resistance suitable for the environment.

2.2.1.12 Where mating parts such as studs and nuts of AISI Standard Type 300 stainless steel or materials with similar galling tendencies are used, they shall be lubricated with a suitable anti-seizure compound compatible with the process conditions.

Note: Torque loading values will differ considerably with and without an anti-seizure compound.

2.2.1.13 O-ring materials shall be compatible with all specified services. Special consideration shall be given to the selection of O-rings for high-pressure services to ensure that they will not be damaged upon rapid depressurization (explosive decompression).

Note: Susceptibility to explosive decompression depends on the gas to which the O-ring is exposed, the compounding of the elastomer, temperature of exposure, the rate of decompression, and the number of cycles.

- **2.2.1.14** When specified, copper or copper alloys shall not be used for parts of machines or auxiliaries in contact with process fluid. Nickel-copper alloy (UNS N04400), bearing babbitt, and precipitation hardened stainless steels are excluded from this requirement.

Note: Certain corrosive fluids in contact with copper alloys have been known to form explosive compounds.

2.2.1.15 Low Temperature

2.2.1.15.1 Pressure casings and rotating elements shall be designed with materials that comply with the paragraphs included in this section.

Note: "Low temperature" may apply to materials that operate or are exposed to considerably higher temperature than the previously used -29°C (-20°F) guidelines.

- **2.2.1.15.2** When specified, other components of the machinery train should also be evaluated for the prevention of brittle fracture due to materials exhibiting change from ductile to brittle fracture as temperatures are reduced.
- **2.2.1.15.3** The purchaser will specify the minimum design metal temperature and concurrent pressure used to establish impact test and other material requirements.

Note: Normally, this will be the lower of the minimum surrounding ambient temperature or minimum fluid pumping temperature; however, the purchaser may specify a minimum design metal temperature based on properties of the pumped fluid, such as auto-refrigeration at reduced pressures.

2.2.1.15.4 To avoid brittle failures, materials and construction for low temperature service shall be suitable for the minimum design metal temperature and concurrent pressure in accordance with the codes and other requirements specified. The purchaser and the vendor shall agree on any special precautions necessary with regard to conditions that may occur during operation, maintenance, transportation, erection, commissioning and testing.

Note: Good design practice should be followed in the selection of fabrication methods, welding procedures, and materials for vendor furnished steel pressure retaining parts that may be subject to temperatures below the ductile-brittle transition temperature. The published design-allowable stresses for materials in internationally recognized standards such as the ASME Code and ANSI standards are based on minimum tensile properties.

Some standards do not differentiate between rimmed, semi-killed, fully killed hot-rolled, and normalized material, nor do they take into account whether materials were produced under fine- or course-grain practices. The vendor should exercise caution in the selection of materials intended for services between -30°C (-20°F) and 40°C (100°F).

2.2.1.15.5 All carbon and low alloy steel pressure-containing components including nozzles, flanges, and weldments shall be impact tested in accordance with the requirements of Section VIII, Division 1, Sections UCS-65 through 68, of the ASME Code or equivalent standard. High-alloy steels shall be tested in accordance with Section VIII, Division 1, Section UHA-51, of the ASME Code or equivalent standard. For materials and thicknesses not covered by Section VIII, Division 1 of the ASME Code or equivalent standards, the purchaser will specify requirements.

Note: Impact testing of a material may not be required depending on the minimum design metal temperature, thermal, mechanical and cyclic loading and the governing thickness. Refer to requirements of Section VIII, Division 1, Section UG-20F of the ASME Code, for example. Governing thickness used to determine impact testing requirements shall be the greater of the following:

- a. The nominal thickness of the largest butt-welded joint.
- b. The largest nominal section for pressure containment, excluding:
 1. Structural support sections such as feet or lugs.
 2. Sections with increased thickness required for rigidity to mitigate shaft deflection.
 3. Structural sections required for attachment or inclusion of mechanical features such as jackets or seal chambers.
- c. One fourth of the nominal flange thickness, including parting flange thickness for axially split casings (in recognition that the predominant flange stress is not a membrane stress).

The results of the impact testing shall meet the minimum impact energy requirements of Section VIII, Division 1, Section UG-84, of the ASME Code or equivalent standard.

- **2.2.1.16** When specified, mutually acceptable coatings shall be applied to the rotating and/or stationary components in the gas path. When coatings are applied to rotating components, the acceptance balance shall be after coatings have been applied. The sequence of procedures for balancing and coating of rotating components shall be mutually agreed.

Note: It is advisable to pre-balance in order to minimize balance corrections and subsequent repair to coating areas for the final acceptance balance. By minimizing the area to be repaired, a final check balance after repair may not be required.

2.2.2 Castings

2.2.2.1 Casting for pressurized service shall be of sound and free from porosity, hot tears, shrink holes, blow holes, cracks, scale, blisters, and similar injurious defects. Surfaces of castings shall be cleaned by sandblasting, shotblasting, chemical cleaning, or other standard methods. Mold-parting

fins and the remains of gates and risers shall be chipped, filed or ground flush.

2.2.2.2 The use of chaplets in castings shall be held to a minimum. Where chaplets are necessary, they shall be clean and corrosion free (plating is permitted) and of a composition compatible with the casting.

2.2.2.3 Fully enclosed cored voids, which become fully enclosed by methods such as plugging, welding, or assembly, are prohibited.

2.2.2.4 Nodular iron castings shall be produced in accordance with an internationally recognized standard such as ASTM A 395.

2.2.3 Forgings

2.2.3.1 The forging material shall be selected from those listed in Annex 1E.

2.2.3.2 All repairs that are not covered by ASTM specifications shall be subject to the purchaser's approval.

2.2.4 Welding

2.2.4.1 Unless otherwise specified, other welding, such as welding on baseplates, non-pressure ducting, lagging, and control panels, shall be performed by welders qualified in accordance with an appropriate recognized standard such as AWS D 1.1 or ASME Section IX.

2.3 CASINGS

2.3.1 Pressure-containing Casings

2.3.1.1 The pressure casing shall be designed in accordance with 2.3.1.1.1 or 2.3.1.1.2, and the casing joint bolting shall be in accordance with 2.3.1.1.3.

2.3.1.1.1 The allowable tensile stress used in the design of the pressure casing (excluding bolting) for any material shall not exceed 0.25 times the minimum ultimate tensile strength for that material at the maximum specified operating temperature. For cast materials, the allowable tensile stress shall be multiplied by the appropriate casting factor as shown in Table 1.2-2.

2.3.1.1.2 Pressure-containing components may be designed with the aid of finite element analysis provided that the design limits comply with Section VIII Division 2 of the ASME Pressure Vessel Code (Code) stress intensity as modified by Equation 1.2-1.

$$\text{MASI} = \text{CSI} \left(\frac{P_{\text{code hydrotest}}}{150} \right) \quad (1.2-1)$$

where

MA SI = maximum allowable stress intensity, kPa (psi),

CSI = code stress intensity, kPa (psi),

$P_{\text{code hydrotest}}$ = code hydrotest pressure, percent of MAWP.

The manufacturer shall state the source of the material properties, such as ASTM, as well as the casting factors applied in his proposal.

2.3.1.1.3 For casing joint bolting, the allowable tensile stress (as determined in 2.3.1.1.1) shall be used to determine the total bolting area based on hydrostatic load and gasket preload as applicable. The preload stress shall not exceed 0.75 times the bolting material minimum yield.

Note 1: In general deflection is the determining consideration in the design of casings. Ultimate tensile or yield strength is seldom the limiting factor.

Note 2: Preloading the bolting is required to prevent unloading the bolted joint due to cyclic operation.

Table 1.2-2—Casting Factors

Type of NDE	Casting factor
Visual, magnetic particle and/or liquid penetrant	0.8
Spot radiography	0.9
Ultrasonic	0.9
Full radiography	1.0

2.3.1.2 For flammable or toxic gases, compressor casings shall be steel or purchaser approved alloy. Expander casings shall be made of material in Annex 1E or approved alloy.

2.3.1.3 For air or nonflammable gases, casings may be steel, ductile iron or cast iron materials depending on the following ratings:

2.3.1.3.1 Casings from ductile iron may be used up to the flange rating according to ANSI B16.42 Class 300.

2.3.1.3.2 Casings from cast iron may be used up to the flange rating according to ANSI B16.1 Class 250.

2.3.1.4 Jackscrews, guide rods, cylindrical casing-alignment dowels and/or other appropriate devices shall be provided to facilitate disassembly and reassembly. Guide rods shall be of sufficient length to prevent damage to the internals or casing studs by the casing during disassembly and reassembly. Lifting lugs or eyebolts shall be provided for lifting only the top half of the casing of axially split casings. When jackscrews are used as a means of parting contacting faces, one of the faces shall be relieved (counterbored or recessed) to prevent a leaking joint or an improper fit caused by marring of the face.

Note: “Other appropriate devices” could be extraction rigs for vertically split equipment, or rollers on the bundles of these machines.

2.3.1.5 The use of threaded holes in pressure parts shall be minimized. To prevent leakage in pressure sections of casings, metal equal in thickness to at least 12 mm ($1/2$ in.), in addition to the allowance for corrosion, shall be left around and below the bottom of drilled and threaded holes. The depth of the threaded holes shall be at least 1.5 times the stud diameter.

2.3.1.6 The sealing of stud clearance holes to prevent leakage is not permitted.

2.3.1.7 Bolting shall be furnished as specified in 2.3.1.7.1 through 2.3.1.7.4

2.3.1.7.1 The details of threading shall conform to ISO 261, ISO 262, ISO 724, and ISO 965 (ASME B1.1).

2.3.1.7.2 Studs shall be supplied on the main joint of axially split casings and bolted end covers of radially split casings. Studs shall be used instead of cap screws, on all other external joints, except where hexagonal head cap screws are essential for assembly purposes and have been approved by the purchaser.

2.3.1.7.3 Adequate clearance shall be provided at bolting locations to permit the use of socket or box wrenches (external only).

2.3.1.7.4 The minimum quality bolting material for pressure joints shall be carbon steel (such as ASTM A 307, Grade B) for cast iron casings and high temperature alloy steel (such as ASTM A 193, Grade B7) for steel casings. Carbon steel nuts (such as ASTM A 194, Grade 2H) shall be used. Where space is limited, case hardened carbon steel nuts (such as ASTM A 563, Grade A) shall be used. For low temperature requirements, see 2.2.1.15.

2.3.1.8 Materials, casting factors, and the quality of any welding shall be equal to those required by Section VIII, Division 1, of the ASME Code. The manufacturer’s data report forms, as specified in the code, are not required.

Note: For low temperature requirements, see 2.2.1.15.

2.3.1.9 Welding of piping, pressure-containing parts, weld repairs and any dissimilar-metal welds shall be performed and inspected by operators and procedures qualified in accordance with Section VIII Division 1, and Section IX of the ASME Code (see 4.2.1.1).

2.3.1.10 The vendor shall be responsible for the review of all repairs and repair welds to ensure that they are properly heat treated and nondestructively examined for soundness and compliance with the applicable qualified procedures (see 2.3.1.8). Repairs shall be nondestructively tested by the same method used to detect the original flaw, however the minimum level of inspection after the repair, shall be by the magnetic particle method in accordance with 4.2.2.4 for magnetic material and by the liquid penetrant method in accordance with 4.2.2.5 for nonmagnetic material.

Unless otherwise specified, procedures for major repairs shall be subject to review by the purchaser prior to any repair.

2.3.1.10.1 The purchaser shall be notified before making a major repair to a pressure-containing part. Major repair, for the purpose of purchaser notification only, is any defect that equals or exceeds any of the three criteria defined below.

1. The depth of the cavity prepared for repair welding exceeds 50% of the component wall thickness.
2. The length of the cavity prepared for repair welding is longer than 150 mm (6 in.) in any direction.
3. The total area of all repairs to the part under repair exceeds 10% of the surface area of the part.

2.3.1.10.2 Actual repairs shall be made as required by the following documents:

1. The repair of plates, prior to fabrication, shall be performed in accordance with the ASTM standard to which the plate was purchased.
2. The repair of castings or forgings shall be performed prior to final machining in accordance with the ASTM standard to which the casting or forging was purchased.
3. The repair of a fabricated casing or the defect in either a weld or the base metal of a cast or fabricated casing, uncovered during preliminary or final machining, shall be performed in accordance with Section VIII of the ASME Pressure Vessel Code.

2.3.1.11 Pressure-containing casings made of wrought materials or combinations of wrought and cast materials shall conform to the conditions specified in 2.3.1.11.1 through 2.3.1.11.5.

2.3.1.11.1 Plate edges shall be inspected by magnetic particle or liquid penetrant examination as required by Section VIII, Division 1, UG-93 (d) (3), of the ASME Code. Alternative standards may be applied when approved by the purchaser.

- **2.3.1.11.2** Accessible surfaces of welds shall be inspected by magnetic particle or liquid penetrant examination after back chipping or gouging and again after post-weld heat treatment. When specified, the quality control of welds that will be inaccessible on completion of the fabrication shall be agreed on by the purchaser and vendor prior to fabrication.

2.3.1.11.3 Pressure-containing welds, including welds of the case to horizontal or vertical joint flanges, shall be full penetration (complete joint) welds unless otherwise approved by the purchaser prior to any fabrication.

Note: This does not apply to auxiliary connections as described in 2.3.2.3.

2.3.1.11.4 Casings and fabrications that are required to be machined to precise dimensions and tolerances to assure assembly shall be heat treated regardless of thickness.

Note: The ASME code does not require all fabrications to be post weld heat treated.

2.3.1.11.5 All pressure-containing welds shall be examined as required by Section VIII, Division 1, of the ASME Code. Requirements for additional examination shall be mutually agreed upon by the vendor and purchaser.

Note: See 2.3.1.12 for required procedures and acceptance criteria.

2.3.1.12 Material Inspection of Pressure-containing Parts

2.3.1.12.1 Regardless of the generalized limits presented in this section, it shall be the vendor's responsibility to review the design limits of all materials and welds in the event that more stringent requirements are specified. Defects that exceed the limits imposed in 2.3.1.12 shall be removed to meet the quality standards cited, as determined by additional magnetic particle or liquid penetrant inspection as applicable prior to repair welding.

2.3.1.12.2 When radiographic, ultrasonic, magnetic particle, or liquid penetrant inspection of welds or materials is required or specified, the procedures and acceptance criteria in 2.3.1.12.2.1 through 2.3.1.12.2.4 shall apply, except as noted (see 4.2.2).

2.3.1.12.2.1 Radiographic examination shall be in accordance with Section VIII, Division 1, UW-51 (100%) and UW-52 (spot), of the ASME Code or an equivalent international standard. Spot radiography shall consist of a minimum of one 150-mm (6-in.) spot radiograph for each 7.6 m (25 ft) of weld on each casing. As a minimum, one spot radiograph is required for each welding procedure and welder used for pressure-containing welds.

2.3.1.12.2.2 Ultrasonic examination shall be in accordance with Section VIII, Division 1, UW 53 and Appendix 12 of the ASME Code.

2.3.1.12.2.3 Magnetic particle examination shall be in accordance with Section VIII, Division 1, Appendix 6, of the ASME Code and ASTM A 709 or equivalent international standards. Linear indications shall be considered relevant only if the major dimension exceeds 1.6 mm (¹/₁₆ in.). Individual indications that are separated by less than 1.6 mm (¹/₁₆ in.) shall be considered continuous.

2.3.1.12.2.4 Liquid penetrant examination shall be in accordance with Section VIII, Division 1, Appendix 8, of the ASME Code.

2.3.1.12.3 Cast steel casing parts shall be examined by magnetic particle methods. Acceptability of defects shall be based on a comparison with the photographs in ASTM E 125 Code. For each type of defect, the degree of severity shall not exceed the limits specified in Table 1.2-3.

Table 1.2-3—Maximum Severity of Defects in Castings

Type	Defect	Degree
I	Linear discontinuities	1
II	Shrinkage	2
III	Inclusions	2
IV	Chills and chaplets	1
V	Porosity	1
VI	Welds	1

2.3.2 Pressure Casing Connections

2.3.2.1 General

2.3.2.1.1 All connections shall be flanged or machined and studded, except where threaded connections are permitted by 2.3.2.3. All process gas connections to the casing shall be suitable for the maximum allowable working pressure as defined in 1.5.17.

2.3.2.1.2 All of the purchaser's connections shall be accessible for disassembly without requiring the machine, or any major part of the machine, to be moved.

2.3.2.1.3 All openings or nozzles for piping connections on pressure casings shall be in accordance with ISO 6708 (ANSI/ASME B1.20.1). Sizes DN 32, DN 65, DN 90, DN 125, DN 175 and DN 225 (1¹/₄, 2¹/₂, 3¹/₂, 5, 7, and 9 NP) shall not be used.

Note: NP designates pipe per ANSI/ASME B1.20.1.

2.3.2.1.4 Connections welded to the casing shall meet the material requirements of the casing, including impact values, rather than the requirements of the connected piping.

2.3.2.1.5 All welding of connections shall be completed before the casing is hydrostatically tested (see 4.3.2).

2.3.2.1.6 For axially split pressure casings, the vendor shall provide connections for complete drainage of all gas passages. For radially split pressure casings, the drains shall be located at the lowest point of each inlet section, the lowest point of the section between the inner and outer casings, and the lowest point of each discharge section. Number and size of drain connections shall be shown in the data sheet.

- **2.3.2.1.7** When specified, individual stage drains, including a drain for the balance piston cavity, shall be provided (see 2.3.2.1.6).

2.3.2.2 Main Process Connections

- **2.3.2.2.1** Main process connections shall be flanged or machined and studded and oriented as specified on the data sheets.

Note: Main process connections include all process inlets and outlets including those for sideloads and intermediate cooling.

2.3.2.2.2 Flanges shall conform to ANSI/ASME B16.1, B16.5, B16.42 or ASME B16.47 Series A or Series B, or other approved standard as applicable, except as specified in 2.3.2.2.3 through 2.3.2.2.4.

Note: ASME B16.47 includes both the former MSS SP 44 and API 605 flanges. Since these are not compatible the MSS were designated Series A and the API Series B. If the Series is not specified, B16.47 defaults to Series A.

2.3.2.2.3 Cast iron flanges shall be flat faced and conform to the dimensional requirements of ISO 7005-2 (ANSI/ASME B16.1 or B16.42). Class 125 flanges shall have a minimum thickness equal to Class 250 for sizes DN 200 (8 NP) and smaller.

Note: NP designates pipe per ANSI/ASME B1.20.1.

2.3.2.2.3.1 Flat face flanges with full raised face thickness are acceptable on casings of all materials.

2.3.2.2.4 Flanges in all materials that are thicker or have a larger outside diameter than required by ISO (ANSI/ASME) are acceptable. Non-standard (oversized) flanges shall be completely dimensioned on the arrangement drawing.

2.3.2.2.5 Flanges shall be full faced or spot faced on the back and shall be designed for through bolting.

2.3.2.2.6 Connections and flanges not in accordance with ISO 7005-1 or 7005-2 (ANSI/ASME B16.1, B16.5, B16.42 or ASME B16.47 Series A or Series B) require purchaser's approval.

- **2.3.2.2.7** When specified, the vendor shall supply mating flanges, studs and nuts for non-standard connections.

2.3.2.2.8 The concentricity of the bolt circle and the bore of all casing flanges shall be such that the area of the machined gasket-seating surface is adequate to accommodate a complete standard gasket without protrusion of the gasket into the fluid flow.

2.3.2.2.9 The flange gasket contact surface shall not have mechanical damage which penetrates the root of the grooves for a radial length of more than 30% of the gasket width.

2.3.2.2.10 Machined and studded connections shall conform to the facing and drilling requirements of ISO 7005-1 or 7005-2 (ANSI/ASME B16.1, B16.5, B16.42 or B16.47). Studs and nuts shall be furnished installed, the first 1.5 threads at both ends of each stud shall be removed.

Note: Threads are removed at the end of the stud to allow the stud to bottom without damaging the end threads in the hole. Threads are removed from both ends of the stud to allow either end of the stud to be inserted into the threaded hole.

2.3.2.2.11 To minimize nozzle loads and facilitate installation of piping, machine flanges shall be parallel to the plane shown on the arrangement drawing to within 0.5 degree.

Studs or bolt holes shall straddle centerlines parallel to the main axis of the equipment.

2.3.2.3 Auxiliary Connections

2.3.2.3.1 Auxiliary connections may include but are not limited to those for vents, liquid injection, drains (see 2.3.2.1.6), water cooling, lube and seal oil, flushing, seal and buffer gas, and balance piston cavity.

2.3.2.3.2 Flanges shall conform to ISO 7005-1 or 7005-2 (ANSI/ASME B16.1, B16.5 or B16.42), as applicable.

2.3.2.3.3 Auxiliary connections shall be socket-welded and flanged, or machined and studded (see 2.3.2.3.4.1).

2.3.2.3.4 A pipe nipple, preferably not more than 150 mm (6 in.) long, schedule 80 seamless minimum, shall be installed in the socket-weld opening. A 2-mm (¹/₁₆-in.) gap, as measured prior to welding, shall be left between the pipe end and the bottom of the socket in the casing. Each pipe nipple shall be provided with a welding-neck, socket-weld, or slip-on flange, except as indicated below.

2.3.2.3.4.1 Auxiliary connections for lube oil, seal oil, or dry gas seal operation shall use weld-neck or slip-on flanges only.

Note: Socket-weld is not allowed due to the possibility of a dirt trap.

2.3.2.3.5 Requirements for Threaded Connections

2.3.2.3.5.1 Threaded openings and bosses for tapered pipe threads shall conform to ISO 7—Parts 1 and 2 (ANSI/ASME B1.20.1).

2.3.2.3.5.2 Pipe threads shall be taper thread conforming to ANSI/ASME B1.20.1.

2.3.2.3.5.3 Threaded connections shall not be seal welded.

2.3.2.3.5.4 For threaded connections that are to be connected to pipe, a pipe nipple, preferably not more than 150 mm (6 in.) long, schedule 160 seamless minimum, shall be installed in the threaded opening. Each pipe nipple shall be provided with a welding-neck, socket-weld or slip-on flange. The nipple and flange materials shall meet the requirements of 2.3.2.1.4.

2.3.2.3.5.5 Threaded openings not required to be connected to piping shall be plugged with solid, round-head steel plugs in accordance with ANSI/ASME B16.11. As a minimum, these plugs shall meet the material requirements of the pressure casing. Plugs that may later require removal shall be of a corrosion resistant material. Plastic plugs are not permitted. A process compatible thread lubricant of proper temperature specification shall be used on all threaded connections. Thread tape shall not be used.

2.3.3 Casing Support Structures

Refer to applicable chapters for details and definition of a casing support structure.

2.3.4 External Forces and Moments

External forces and moment information can be found in the applicable chapters.

2.4 GUIDE VANES, STATORS, AND STATIONARY INTERNALS

Refer to subsequent chapters for specific requirements.

2.5 ROTATING ELEMENTS

2.5.1 Shaft ends for couplings shall conform to the requirements of API Std 671.

2.5.2 The rotor shaft sensing areas to be observed by radial-vibration probes shall be concentric with the bearing journals. All shaft sensing areas (both radial vibration and axial position) shall be free from stencil or scribe marks or any other surface discontinuity for a minimum of one probe-tip diameter on each side of the probe. These areas shall not be metalized or plated except vendors with proven experience or test data may metalize shafts to reduce electrical runout.

Note 1: Shaft materials such as 17-4 PH frequently exhibit excessive electrical runout. Some vendors have successfully reduced electrical runout to acceptable levels with treatments such as the application of 1 mm (0.04 in.) radial thickness of metalized aluminum.

Note 2: Proximity probe oscillator/demodulators must be calibrated for the appropriate target material.

2.5.3 The final surface finish of sensing areas to be observed by radial vibration probes shall be a maximum of 1.0 μm (32 $\mu\text{in.}$) Ra, preferably obtained by honing or burnishing. These areas shall be properly demagnetized to the levels specified in API Std 670, or otherwise treated so that the combined total electrical and mechanical runout does not exceed 5 μm (0.25 mil) for areas to be observed by radial vibration probes.

Note: If all reasonable efforts fail to achieve the limits noted in 2.5.3, the vendor and the purchaser should mutually agree on alternate acceptance criteria.

2.5.4 The design of stressed parts shall include proper evaluation of the stress concentration factor (SCF) for the geometry. The design of stressed rotating parts shall include fillets that will limit the SCF.

Note: Areas of concern include the impeller vane-to-disk intersections, keyways, and shaft section changes.

2.5.5 Replaceable thrust collars shall be furnished only when they are required for removal of shaft end seals. When replaceable collars are furnished (for assembly and maintenance purposes), they shall be positively locked to

the shaft to prevent fretting. When integral collars larger than 5 in. diameter are furnished, they shall be provided with at least 3 mm ($1/8$ in.) of additional stock to enable refinishing if the collar is damaged.

Note: Integral thrust collars are required unless thrust collars must be removed.

2.5.6 Both faces of thrust collars shall have a surface finish of not more than $0.4\ \mu\text{m}$ ($16\ \mu\text{in.}$) Ra, and the axial total indicator runout of either face shall not exceed $13\ \mu\text{m}$ (0.0005 in.).

2.5.7 Stationary labyrinth seals shall have replaceable shaft sleeves or be designed so that major rotating parts need not be replaced. Labyrinth-type seals with the teeth on the rotating element shall have replaceable non-rotating element of an abrasable material.

2.5.8 The design of the shaft-sleeve-impeller assemblies shall not create temporary nor permanent distortions of the rotor assembly. The method of attaching the impeller shall adequately maintain concentricity and balance under all specified operating conditions, including overspeed to trip speed.

2.5.9 Compressor designs that do not require a balance piston are acceptable.

2.5.10 Impellers

2.5.10.1 Impellers may be closed, consisting of a hub, blades, and a cover; or semi-open, consisting of a hub and blades. Impellers shall be of welded, brazed, milled, electro-eroded or cast construction. Other manufacturing methods may be permitted if approved by the purchaser. Each impeller shall be marked with a unique identification number.

2.5.10.2 Impellers may consist of forged and cast components. Welds in the gas passageway shall be smooth and free of weld spatter. Impellers shall be heat treated and stress relieved after welding. Impeller blade entrance and exit tips shall not have knife edges.

2.5.10.3 All accessible weld surfaces on welded impellers and finish machined surfaces of electro eroded impellers shall be inspected by visual and magnetic particle or liquid penetrant examination. Impeller fabrications resulting in joints that are not visually accessible, such as brazed joints, shall be subjected to ultrasonic examination to verify joint integrity. Refer to 4.2.2 for material inspection methods and 4.2.2.1.1 for acceptance criteria.

2.5.10.4 Cast impellers hubs and covers shall be inspected by radiographic or ultrasonic means prior to finish machining. Details of inspection techniques and acceptance criteria shall be mutually agreed upon by the vendor and the purchaser. Refer to 4.2.2 for material inspection methods and 4.2.2.1.1 for acceptance criteria.

2.5.10.5 Upgrade or repair welding of cast impellers may be permitted only with the purchaser's approval.

2.5.10.6 Welding as a means of balancing an impeller is not permitted.

2.5.10.7 After the overspeed test described in 4.3.3, each impeller shall be examined all over by means of magnetic particle or liquid penetrant methods. Refer to 4.2.2 for material inspection methods and 4.2.2.1.1 for acceptance criteria.

2.6 DYNAMICS

2.6.1 General

Note: Refer to API Publ 684 for more information on rotor dynamics.

2.6.1.1 In the design of rotor-bearing systems, consideration shall be given to all potential sources of periodic forcing phenomena (excitation) which shall include, but are not limited to, the following sources:

- a. Unbalance in the rotor system.
- b. Oil-film instabilities (whirl).
- c. Internal rubs.
- d. Blade, vane, nozzle, and diffuser passing frequencies.
- e. Gear-tooth meshing and side bands.
- f. Coupling misalignment.
- g. Loose rotor-system components.
- h. Hysteretic and friction whirl.
- i. Boundary-layer flow separation.
- j. Acoustic and aerodynamic cross-coupling forces.
- k. Asynchronous whirl.
- l. Ball and race frequencies of rolling element bearings.
- m. Electrical line frequency.

Note 1: The frequency of a potential source of excitation may be less than, equal to, or greater than the rotational speed of the rotor.

Note 2: When the frequency of a periodic forcing phenomenon (excitation) applied to a rotor-bearing support system coincides with a natural frequency of that system, the system will be in a state of resonance. A rotor-bearing support system in resonance may have the magnitude of its normal vibration amplified. The magnitude of amplification and, in the case of critical speeds, the rate of change of the phase-angle with respect to speed, are related to the amount of damping in the system.

2.6.1.2 For the purposes of this standard, a resonant condition of concern, such as lateral and torsional critical speeds, are those with an amplification factor (AF) equal to or greater than 2.5 (see Figure 1.2-1).

2.6.1.3 Resonances of structural support systems that are within the vendor's scope of supply and that affect the rotor vibration amplitude shall not occur within the specified operating speed range or the specified separation margins (SM) (see 2.6.2.10). The effective stiffness of the structural support shall be considered in the analysis of the dynamics of the rotor-bearing-support system (see 2.6.2.4d).

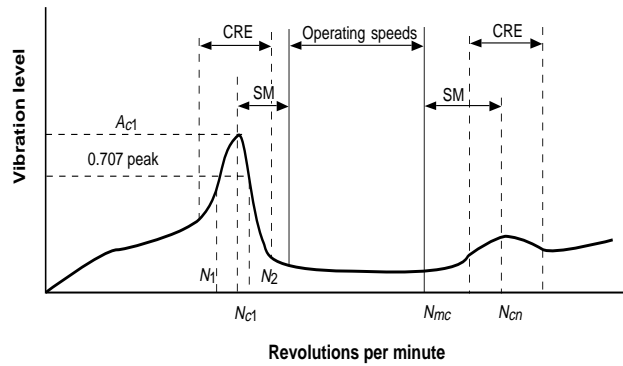

- N_{c1} = Rotor first critical, center frequency, cycles per minute.
- N_{cn} = Critical speed, n th.
- N_{mc} = Maximum continuous speed, 105%.
- N_1 = Initial (lesser) speed at $0.707 \times$ peak amplitude (critical).
- N_2 = Final (greater) speed at $0.707 \times$ peak amplitude (critical).
- $N_2 - N_1$ = Peak width at the half-power point.
- AF = Amplification factor.
- $= \frac{N_{c1}}{N_2 - N_1}$
- SM = Separation margin.
- CRE = Critical response envelope.
- A_{c1} = Amplitude at N_{c1} .
- A_{cn} = Amplitude at N_{cn} .

Note: The shape of the curve is for illustration only and does not necessarily represent any actual rotor response plot.

Figure 1.2-1—Rotor Response Plot

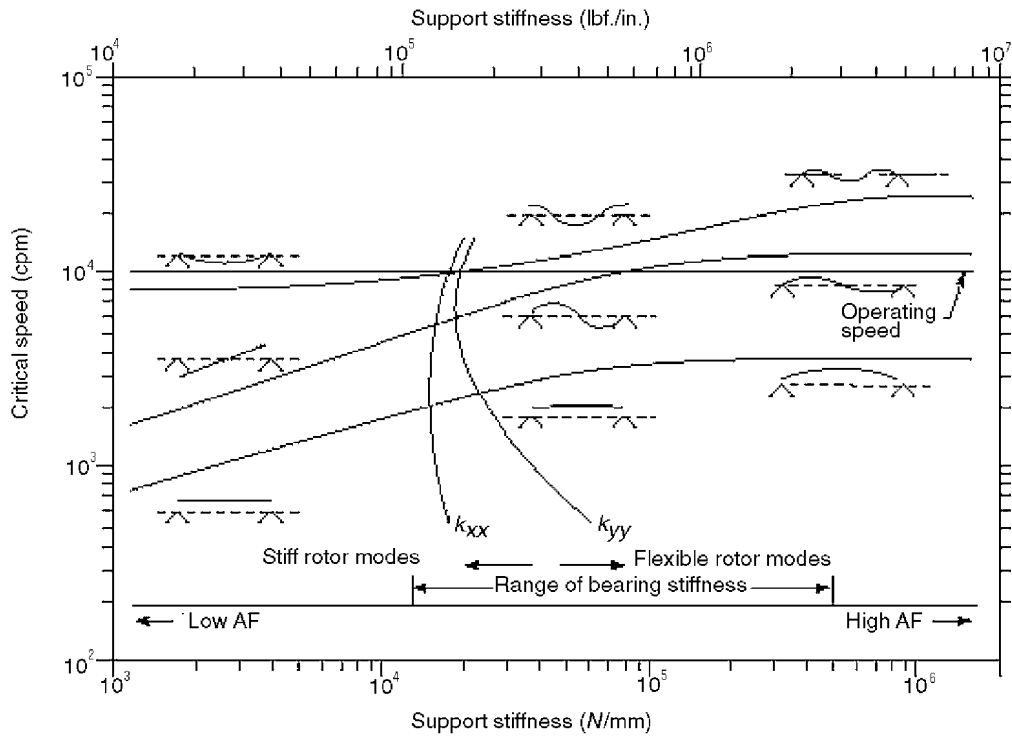

Figure 1.2-2—Undamped Stiffness Map

Note: Resonances of structural support systems may adversely affect the rotor vibration amplitude.

- **2.6.1.4** The vendor who is specified to have unit responsibility for the complete drive train shall communicate the existence of any undesirable running speeds in the range from zero to trip speed. A list of all undesirable speeds from zero to trip shall be submitted to the purchaser for his review and included in the instruction manual (see Annex B of the applicable chapter).

Note: Examples of undesirable speeds are those caused by the rotor lateral critical speeds, system torsionals, and blading modes.

2.6.2 Lateral Analysis

2.6.2.1 Critical speeds and their associated AFs shall be determined by means of a damped unbalanced rotor response analysis.

2.6.2.2 The location of all critical speeds below the trip speed shall be confirmed on the test stand during the mechanical running test (see 2.6.3.1). The accuracy of the analytical model shall be demonstrated (see 2.6.3).

2.6.2.3 Before carrying out the damped unbalanced response analysis, the vendor shall conduct an undamped analysis to identify the undamped critical speeds and determine their mode shapes located in the range from 0% – 125% of trip speed. Unless otherwise specified, the results of the undamped analysis shall be furnished. The presentation of the results shall include:

- a. Mode shape plots (relative amplitude vs. axial position on the rotor).
- b. Critical speed-support stiffness map (frequency vs. support stiffness). Superimposed on this map shall be the calculated system support stiffness; horizontal (k_{xx}), and vertical (k_{yy}) (see Figure 1.2-2).

Note: For machinery with widely varying bearing loads and/or load direction such as overhung style machines, the vendor may propose to substitute mode shape plots for the undamped critical speed map and list the undamped critical speed for each of the identified modes.

2.6.2.4 The damped unbalanced response analysis shall include but shall not be limited to the following:

Note: The following is a list of items the analyst is to consider. It does not address the details and product of the analysis which is covered in 2.6.2.7 and 2.6.2.8.

- a. Rotor masses, including the mass moment of coupling halves, stiffness, and damping effects (for example, accumulated fit tolerances, fluid stiffening and damping).
- b. Bearing lubricant-film stiffness and damping values including changes due to speed, load, preload, range of oil temperatures, maximum to minimum clearances resulting from accumulated assembly tolerances, and the effect of asymmetrical loading which may be caused by gear forces, side streams, eccentric clearances, etc.

c. For tilt-pad bearings, the pad pivot stiffness.

d. Support stiffness, mass, and damping characteristics, including effects of frequency dependent variation. The term “support” includes the foundation or support structure, the base, the machine frame and the bearing housing as appropriate. For machines whose bearing support system stiffness values are less than or equal to 3.5 times the bearing oil film stiffness values, support stiffness values derived from modal testing or calculated frequency dependent support stiffness and damping values (impedances) shall be used. The vendor shall state the support stiffness values used in the analysis and the basis for these values (for example, modal tests of similar rotor support systems, or calculated support stiffness values).

Note 1: The support stiffness should in most cases be no more than 8.75×10^6 N/mm (5×10^6 lb./in.).

Note 2: Guide lines are used to define whether or not bearing support stiffness should be considered. While modal testing of the actual bearing support system would be preferred, an analytical analysis (such as FEA) is permitted.

e. Rotational speed, including the various starting-speed detents, operating speed and load ranges (including agreed-upon test conditions if different from those specified), trip speed, and coast-down conditions.

f. The influence, over the operating range, of the hydrodynamic stiffness and damping generated by the casing shaft end seals.

g. The location and orientation of the radial vibration probes which shall be the same in the analysis as in the machine.

2.6.2.5 In addition to the damped unbalanced response analysis requirements of 2.6.2.4, for machines equipped with rolling element bearings, the vendor shall state the bearing stiffness and damping values used for the analysis and either the basis for these values or the assumptions made in calculating the values.

- **2.6.2.6** When specified, the effects of other equipment in the train shall be included in the damped unbalanced response analysis (that is, a train lateral analysis shall be performed).

Note: In particular, this analysis should be considered for machinery trains with rigid couplings.

2.6.2.7 A separate damped unbalanced response analysis shall be conducted for each critical speed within the speed range of 0% – 125% of trip speed. Unbalance shall analytically be placed at the locations that have been determined by the undamped analysis to affect the particular mode most adversely. For the translatory (symmetric) modes, the unbalance shall be based on the sum of the journal static loads and shall be applied at the location of maximum displacement. For conical (asymmetric) modes, an unbalance shall be added at the location of maximum displacement nearest to each journal bearing. These unbalances shall be 180 degrees out of phase and of a magnitude based on the static load on the adjacent bearing. Figures 1.2-3a, 1.2-3b and 1.2-3c show the typi-

cal mode shapes and indicates the location and definition of U for each of the shapes. The magnitude of the unbalances shall be 4 times the value of U as calculated by Equations 1.2-2a or 1.2-2b.

In SI units:

$$U = 6350(W/N) \quad (1.2-2a)$$

or 250 μm mass displacement, whichever is greater.

In U.S. Customary units:

$$U = 4(W/N) \quad (1.2-2b)$$

or 10 $\mu\text{in.}$ mass displacement, whichever is greater.

where

U = input unbalance for the rotor dynamic response analysis in g-mm (oz.-in.),

N = maximum continuous operating speed,

W = journal static load in kg (lb.), or for bending modes where the maximum deflection occurs at the shaft ends, the overhung mass (that is the mass of the rotor outboard of the bearing) in kg (lb.) (see Figures 1.2-3a, 1.2-3b and 1.2-3c).

Note: The limits on mass displacement are in general agreement with the capabilities of conventional balance machines, and are necessary to invoke for small rotors running at high speeds.

2.6.2.7.1 For rotors where the impellers are cantilevered beyond the journal bearings, unbalance shall be added at the impellers and components such as locknuts, shaft end seals and the coupling for the case of the non integrally geared rotors. Each undamped mode that is less than 125% of trip speed shall be analyzed. The modes shall be calculated at minimum and maximum support stiffness and in the case of integrally geared rotors include the change in support stiffness resulting from minimum to maximum torque transmitted through the gearing. The unbalance shall be located at or close to the component center of gravity and phased to create maximum synchronous response amplitude.

2.6.2.7.2 For rotors which are between bearing designs, unbalance shall be added at the impellers and major rotor components such as balance drums and couplings. The unbalance shall be located at or close to the component center of gravity and phased to create maximum synchronous response amplitude.

2.6.2.8 As a minimum, the unbalanced response analysis shall produce the following:

Note: The following is the list of analysis details and identifies the deliverables. The items to be considered in the analysis were identified in 2.6.2.4.

- a. Identification of the frequency of each critical speed in the range from 0% – 125% of the trip speed.
- b. Frequency, phase and response amplitude data (Bode plots) at the vibration probe locations through the range of each critical speed resulting from the unbalance specified in 2.6.2.7.
- c. The plot of deflected rotor shape for each critical speed resulting from the unbalances specified in 2.6.2.7, showing the major-axis amplitude at each coupling plane of flexure, the centerlines of each bearing, the locations of each radial probe, and at each seal throughout the machine as appropriate. The minimum design diametral running clearance of the seals shall also be indicated.
- d. Additional Bode plots that compare absolute shaft motion with shaft motion relative to the bearing housing for machines where the support stiffness is less than 3.5 times the oil-film stiffness.

2.6.2.9 Additional analyses shall be made for use with the verification test specified in 2.6.3. The location of the unbalance shall be determined by the vendor. Any test stand parameters which influence the results of the analysis shall be included.

Note: For most machines, there will only be one plane readily accessible for the placement of an unbalance; for example, the coupling flange on a single ended drive machine, or the impeller hub or disk on an integrally geared machine, or expander-compressors. However, there is the possibility that more planes are available such as axial compressor balance planes, or on through drive compressors. When this occurs, and there is the possibility of exciting other criticals, multiple runs may be required.

2.6.2.10 The damped unbalanced response analysis shall indicate that the machine will meet the following SM:

- a. If the AF at a particular critical speed is less than 2.5, the response is considered critically damped and no SM is required.
- b. If the AF at a particular critical speed is 2.5 or greater and that critical speed is below the minimum speed, the SM (as a percentage of the minimum speed) shall not be less than the value from Equation 1.2-3 or the value 16 whichever is less.

$$SM = 17 \left(1 - \frac{1}{AF - 1.5} \right) \quad (1.2-3)$$

- c. If the AF at a particular critical speed is equal to 2.5 or greater and that critical speed is above the maximum continuous speed, the SM (as a percentage of the maximum

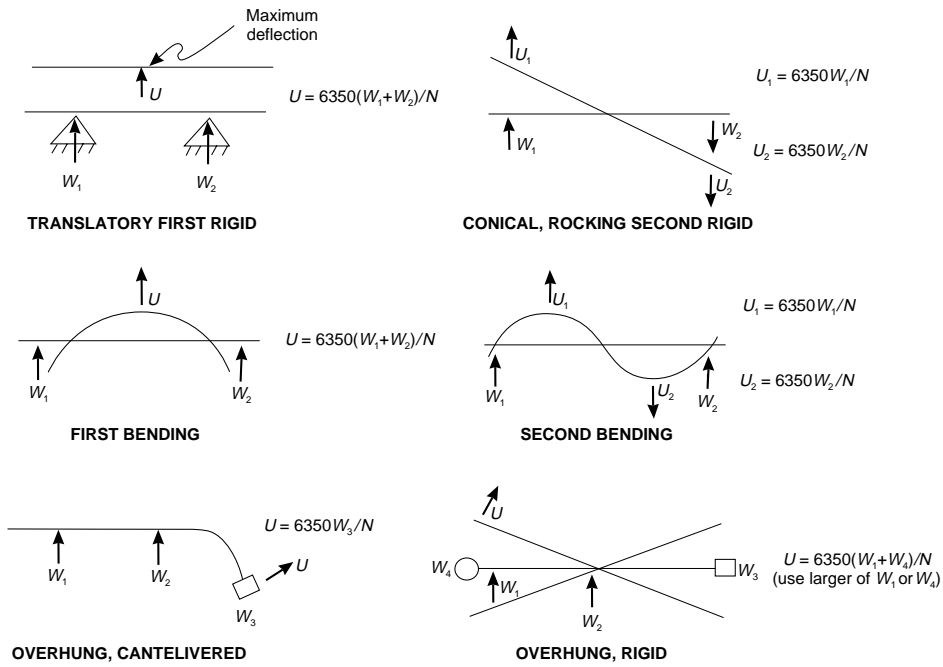

Figure 1.2-3a—Typical Mode Shapes—Between-bearing and Overhung Units (SI Units)

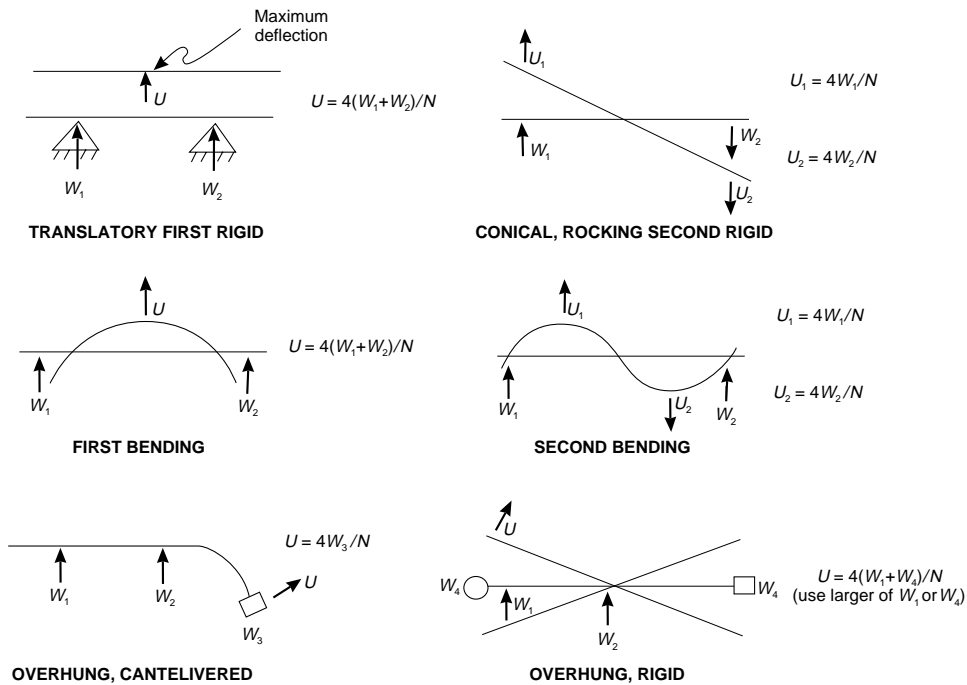

Figure 1.2-3b—Typical Mode Shapes—Between-bearing and Overhung Units (U.S. Customary Units)

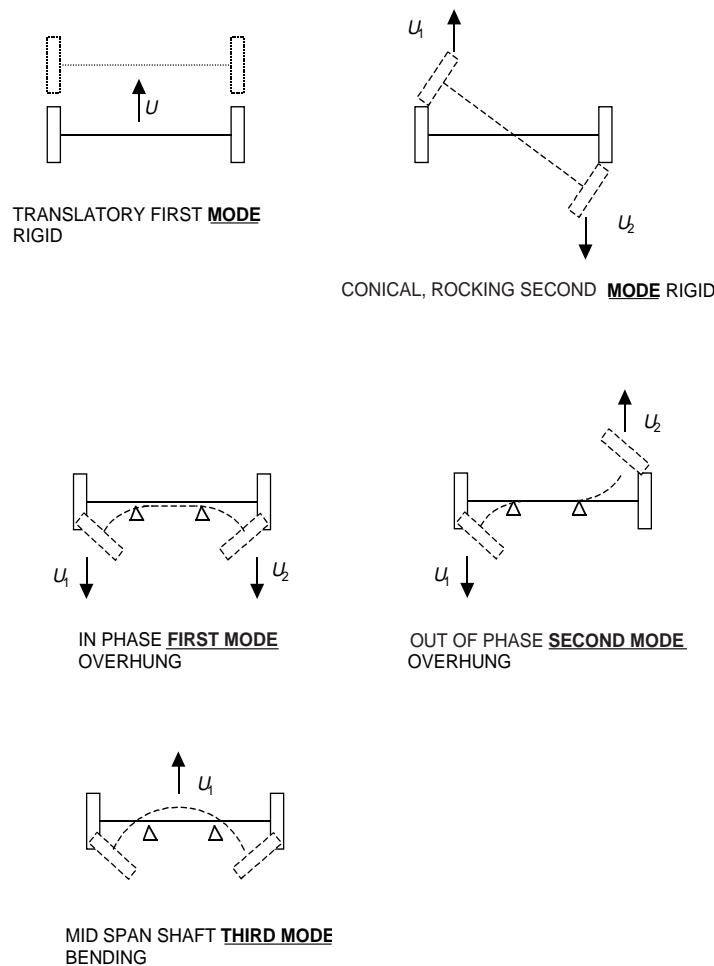

Figure 1.2-3c—Typical Mode Shapes—Integrally Geared Pinion Type Rotors

continuous speed) shall not be less than the value from Equation 1.2-4 or the value of 26 which ever is less.

$$SM = 10 + 17 \left(1 - \frac{1}{AF - 1.5} \right) \quad (1.2-4)$$

2.6.2.11 The calculated unbalanced peak to peak amplitudes (see 2.6.2.8b) shall be multiplied using the correction factor calculated from Equation 1.2-5. The correction factor shall have a value greater than 0.5.

$$CF = \frac{A_1}{A_{4x}} \quad (1.2-5)$$

where

CF = correction factor,

A_1 = amplitude limit, calculated using Equations 1.2-6a or 1.2-6b in microns (mils) peak to peak,

A_{4x} = peak to peak amplitude at the probe location per requirements of 2.6.2.8c in microns (mils) peak to peak.

In SI units:

$$A_1 = 25 \sqrt{\frac{12000}{N}} \quad (1.2-6a)$$

In U.S. Customary units:

$$A_1 = \sqrt{\frac{12000}{N}} \quad (1.2-6b)$$

where

N = maximum continuous operating speed, in rpm.

2.6.2.12 The calculated major-axis, peak-to-peak, unbalanced rotor response amplitudes, corrected in accordance with 2.6.2.11 at any speed from zero to trip speed shall not exceed 75% of the minimum design diametral running clearances throughout the machine (with the exception of floating-ring seal locations). For machines with abradable seals, the response amplitude to the running clearance shall be mutually agreed.

Note: Running clearances may be different than the assembled clearances with the machine shutdown.

2.6.2.13 If the analysis indicates that the SMs still cannot be met or that a non-critically damped response peak falls within the operating speed range and the purchaser and vendor have agreed that all practical design efforts have been exhausted, then acceptable amplitudes shall be mutually agreed upon by the purchaser and the vendor, subject to the requirements of 2.6.3.3.

- **2.6.2.14** When specified, in addition to the other requirements of 2.6.2, the lateral analysis report shall include the following:

- a. Dimensional data of the bearing design in sufficient detail to enable calculations of stiffness and damping coefficients.
- b. Shaft geometry with sufficient detail to model the shaft including the location of bearing centerlines and mounted components.
- c. The weight, polar and transverse moments of inertia and center of gravity of the impellers, balance piston, shaft end seals and coupling(s) with sufficient detail to conduct an independent analysis of the rotor.
- d. The input model used for the vendors analysis.
- e. The support stiffness used in the analysis and its basis.

2.6.3 Unbalanced Rotor Response Verification Test

2.6.3.1 An unbalanced rotor response test shall be performed as part of the mechanical running test (see 4.3 of the applicable chapter), and the results shall be used to verify the analytical model. The actual response of the rotor on the test stand to the same arrangement of unbalance and bearing loads as was used in the analysis specified in 2.6.2.9 shall be the criterion for determining the validity of the damped unbalanced response analysis. To accomplish this, the requirements of 2.6.3.1.1 through 2.6.3.1.6 shall be followed.

2.6.3.1.1 During the mechanical running test (see 4.3 of the applicable chapter), the amplitudes and phase angle of the shaft vibration from zero to trip speed, shall be recorded. The gain of any analog recording instruments used shall be preset before the test so that the highest response peak is within 60% – 100% of the recorder's full scale on the test-unit coast-down (deceleration).

Note: This set of readings is normally taken during a coastdown, with convenient increments of speed such as 50 rpm. Since at this point the rotor is balanced, any vibration amplitude and phase detected should be the result of residual unbalance and mechanical and electrical runout.

2.6.3.1.2 The location of critical speeds below the trip speed shall be established.

2.6.3.1.3 The unbalance which was used in the analysis performed in 2.6.2.9, shall be added to the rotor in the location used in the analysis. The unbalance shall not exceed 8 times the value from Equations 1.2-2a or 1.2-2b.

2.6.3.1.4 The machine shall then be brought up to the trip speed and the indicated vibration amplitudes and phase shall be recorded using the same procedure used for 2.6.3.1.1.

2.6.3.1.5 The corresponding indicated vibration data taken in accordance with 2.6.3.1.1 shall be vectorially subtracted from the results of this test.

Note: It is practical to store the residual unbalance vibration measurements recorded in the step at 2.6.3.1.1 and by use of computer code perform the vectorial subtraction called for in this paragraph at each appropriate speed. This makes the comparison of the test results with the computer analysis of 2.6.2.9 quite practical. It is necessary for probe orientation be the same for the analysis and the machine for the vectorial subtraction to be valid.

2.6.3.1.6 The results of the mechanical run including the unbalance response verification test shall be compared with those from the analytical model specified at 2.6.2.9.

2.6.3.2 The vendor shall correct the model if it fails to meet either of the following criteria:

- a. The actual critical speeds determined on test shall not deviate from the corresponding critical speeds predicted by analysis by more than 5%. Where the analysis predicts more than one critical speed in a particular mode (due, for example, to the bearing characteristics being significantly different horizontally and vertically or between the two ends of the machine), the test value shall not be lower than 5% below the lowest predicted value nor higher than 5% above the highest predicted value.

Note: It is possible, particularly on electric motors, that the vertical and horizontal stiffness are significantly different and the analysis will predict two differing critical speeds. Should the operating speed fall between these critical speeds, these two critical speeds should be treated separately, as if they resulted from separate modes.

- b. The actual major axis amplitude of peak responses from test, including those critically damped, shall not exceed the

predicted values. The predicted peak response amplitude range shall be determined from the computer model based on the four radial probe locations.

2.6.3.3 If the support stiffness is less than 2 times the bearing oil film stiffness, the absolute vibration of the bearing housing shall be measured and vectorially added to the relative shaft vibration, in both the balanced (see 2.6.3.1.1) and in the unbalanced (see 2.6.3.1.3) condition before proceeding with the step specified in 2.6.3.1.6. In such a case, the measured response shall be compared with the predicted absolute shaft movement.

2.6.3.4 Unless otherwise specified, the verification test of the rotor unbalance shall be performed only on the first rotor tested, if multiple identical rotors are purchased.

2.6.3.5 The vibration amplitudes and phase from each pair of *x-y* vibration probes shall be vectorially summed at each vibration response peak after correcting the model, if required, to determine the maximum amplitude of vibration. The major-axis amplitudes of each response peak shall not exceed the limits specified in 2.6.2.12.

2.6.4 Additional Testing

2.6.4.1 Additional testing is required (see 2.6.4.2) if from the shop verification test data (see 2.6.3) or from the damped, corrected unbalanced response analysis (see 2.6.3.3), it appears that either of the following conditions exists:

- a. Any critical response which fails to meet the SM requirements (see 2.6.2.10) or which falls within the operating speed range.
- b. The clearance requirements of 2.6.2.12 have not been met.

Note: When the analysis or test data does not meet the requirements of the standard, additional more stringent testing is required. The purpose of this additional testing is to determine on the test stand that the machine will operate successfully.

2.6.4.2 Unbalance weights shall be placed as described in 2.6.2.7; this may require disassembly of the machine. Unbalance magnitudes shall be achieved by adjusting the indicated unbalance that exists in the rotor from the initial run to raise the displacement of the rotor at the probe locations to the vibration limit defined by Equations 1.2-6a or 1.2-6b (see 2.6.2.11) at the maximum continuous speed; however, the unbalance used shall be no less than twice or greater than 8 times the unbalance limit specified in 2.6.2.7, Equations 1.2-2a or 1.2-2b. The measurements from this test, taken in accordance with 2.6.3.1.1 and 2.6.3.1.2, shall meet the following criteria:

- a. At no speed outside the operating speed range, including the SM, shall the shaft deflections exceed 90% of the minimum design running clearances.

- b. At no speed within the operating speed range, including the SM, shall the shaft deflections exceed 55% of the minimum design running clearances or 150% of the allowable vibration limit at the probes (see 2.6.2.11).

2.6.4.3 The internal deflection limits specified in 2.6.4.2 items a and b shall be based on the calculated displacement ratios between the probe locations and the areas of concern identified in 2.6.2.12 based on a corrected model, if required. Actual internal displacements for these tests shall be calculated by multiplying these ratios by the peak readings from the probes. Acceptance will be based on these calculated displacements or inspection of the seals if the machine is opened. Damage to any portion of the machine as a result of this testing shall constitute failure of the test. Minor internal seal rubs that do not cause clearance changes outside the vendor's new-part tolerance do not constitute damage.

2.6.5 Level I Stability Analysis

2.6.5.1 A stability analysis shall be performed on all centrifugal or axial compressors and/or radial flow rotors except those rotors whose maximum continuous speed is below the first critical speed in accordance with 2.6.2.3, as calculated on rigid supports. For this analysis, the machine inlet and discharge conditions shall be at either the rated condition or another operating point unless the vendor and purchaser agree upon another operating point.

Note: Level I analysis was developed to fulfill two purposes: first, it provides an initial screening to identify rotors that do not require a more detailed study. The approach as developed is conservative and not intended as an indication of an unstable rotor. Second, the Level I analysis specifies a standardized procedure applied to all manufacturers similar to that found in 2.6.2. (Refer to API Publ 684, 1.6 for a detailed explanation.)

2.6.5.2 The model used in the Level I analysis shall include the items listed in 2.6.2.4 together with the effects of squeeze film dampers where used.

2.6.5.3 All components shall be analyzed using the mean values of oil inlet temperature and the extremes of the operating limits for clearance to produce the minimum log decrement.

2.6.5.4 When tilt pad journal bearings are used, the analysis shall be performed with synchronous tilt pad coefficients.

2.6.5.5 For rotors that have quantifiable external radial loading (e.g., integrally geared compressors), the stability analysis shall also include the external loads associated with the operating conditions defined in 2.6.5.1. For some rotors, the unloaded (or minimal load condition) may represent the worst stability case and should be considered.

2.6.5.6 The anticipated cross coupling, Q_A , present in the rotor is defined by the following procedures:

a. For centrifugal compressors:

The parameters in Equation 1.2-7 shall be determined based on the specified operating condition in 2.6.5.1.

$$Q_A = \frac{HP \times B_c \times C}{D_c \times H_c \times N} \times \frac{\rho_d}{\rho_s} \quad (1.2-7)$$

Equation 1.2-7 is calculated for each impeller of the rotor. Q_A is equal to the sum of q_A for all impellers.

b. For axial flow rotors:

$$q_A = \frac{HP \times B_t \times C}{D_t \times H_t \times N} \quad (1.2-8)$$

Equation 1.2-8 is calculated for each stage of the rotor. Q_A is equal to the sum of q_A for all stages.

2.6.5.7 An analysis shall be performed with a varying amount of cross coupling introduced at the rotor mid-span for between bearing rotors or at the center of gravity of the stage or impeller for single overhung rotors. For double overhung rotors, the cross coupling shall be placed at each stage or impeller concurrently and should reflect the ratio of the anticipated cross coupling, q_A , calculated for each impeller or stage.

2.6.5.8 The applied cross coupling shall extend from zero to the minimum of:

- A level equal to 10 times the anticipated cross coupling, Q_A .
- The amount of the applied cross coupling required to produce a zero log decrement, Q_0 . This value can be reached by extrapolation or linear interpolation between two adjacent points on the curve.

2.6.5.9 A plot of the calculated log decrement, δ , for the first forward mode shall be prepared for the minimum and maximum component clearances. Each curve shall contain a minimum of five calculated stability points. The ordinate (y-axis) shall be the log decrement. The abscissa (x-axis) shall be the applied cross coupling with the range defined in 2.6.5.8. For double overhung rotors, the applied cross coupling will be the sum of the cross coupling applied to each impeller or stage.

A typical plot is presented in Figure 1.2-4. Q_0 and δ_A are identified as the minimum values from either component clearance curves.

2.6.5.10 Level I Screening Criteria

a. For centrifugal compressors:

If any of the following criteria apply, a Level II stability analysis shall be performed:

- $Q_0/Q_A < 2.0$.
- $\delta_A < 0.1$.
- $2.0 < Q_0/Q_A < 10$ and CSR is contained in Region B of Figure 1.2-5.

Otherwise, the stability is acceptable and no further analyses are required.

b. For axial flow rotors:

If $\delta_A < 0.1$, a Level II stability analysis shall be performed. Otherwise, the stability is acceptable and no further analyses are required.

2.6.6 Level II Stability Analysis

2.6.6.1 A Level II analysis, which reflects the actual operating behavior of the rotor, shall be performed as required by 2.6.5.10.

2.6.6.2 The Level II analysis shall include the dynamic effects from all sources that contribute to the overall stability of the rotating assembly as appropriate. These dynamic effects shall replace the anticipated cross coupling, Q_A . These sources may include, but are not limited to, the following:

- Labyrinth seals.
- Balance piston.
- Impeller/blade flow.
- Shrink fits.
- Shaft material hysteresis.

It is recognized that methods may not be available at present to accurately model the destabilizing effects from all sources listed above. The vendor shall state how the sources are handled in the analysis.

2.6.6.3 The Level II analysis shall be calculated for the operating conditions defined in 2.6.5.1 extrapolated to maximum continuous speed. The modeling requirements of 2.6.5.2, 2.6.5.4 and 2.6.5.5 shall also apply. The component dynamic characteristics shall be calculated at the extremes of the allowable operating limits of clearance and oil inlet temperature to produce the minimum log decrement.

2.6.6.4 The frequency and log decrement of the first forward damped mode shall be calculated for the following conditions (except for double overhung machines where the first two forward modes must be considered):

- Rotor and support system only (basic log decrement, δ_b).
- For the addition of each group of destabilizing effects utilized in the analysis.
- Complete model including all destabilizing forces (final log decrement, δ_f).

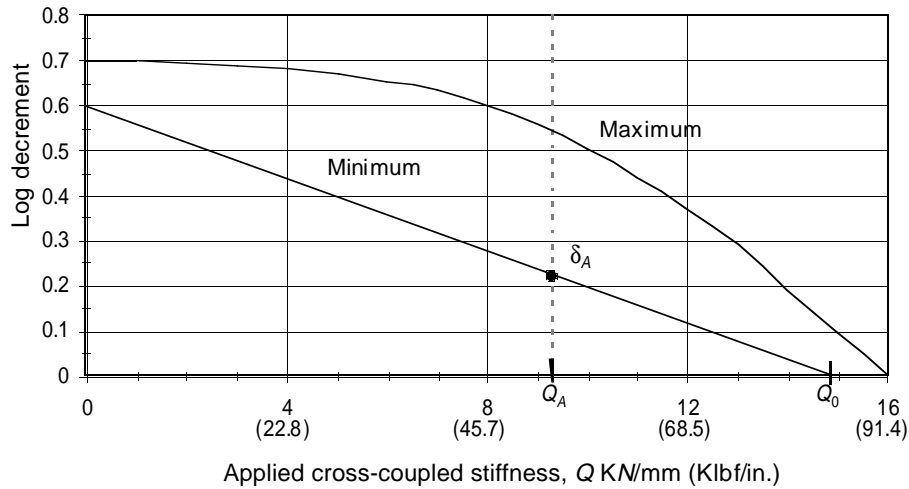

Figure 1.2-4—Typical Plot of Applied Cross-coupled Stiffness vs. Log Decrement

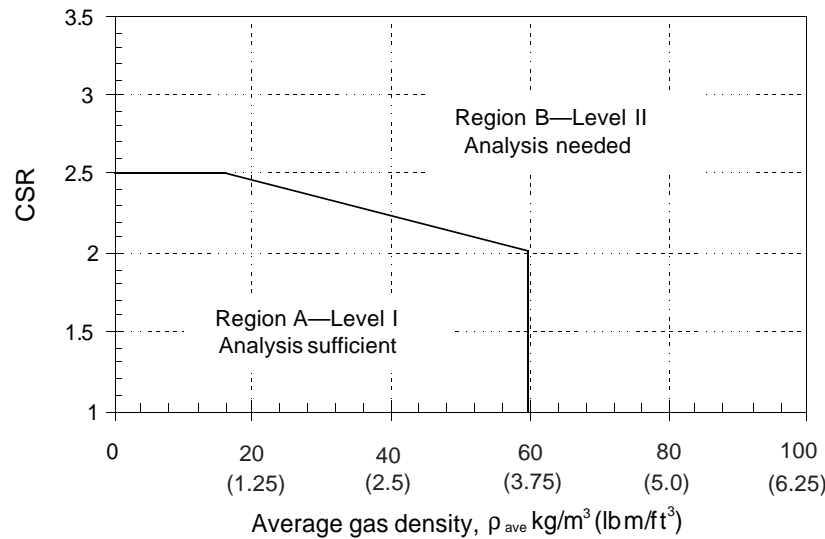

Figure 1.2-5—Level I Screening Criteria

2.6.6.5 Acceptance Criteria

The Level II stability analysis shall indicate that the machine, as calculated in 2.6.6.1 through 2.6.6.3, shall have a final log decrement, δ_f , greater than 0.1.

2.6.6.6 If after all practical design efforts have been exhausted to achieve the requirements of 2.6.6.5, acceptable levels of the log decrement, δ_f , shall be mutually agreed upon by the purchaser and vendor.

Note: This stability analysis section represents the first uniform methodology specified for centrifugal compressors, steam turbines and axial and/or radial flow rotors. The analysis method and the acceptance criteria specified are unique in that no manufacturer has used these exact methods to evaluate the susceptibility of their equipment

to subsynchronous instability. When these requirements are included within a specification, all manufacturers are expected to analyze their rotors accordingly. However, it should be recognized that other analysis methods and continuously updated acceptance criteria have been used successfully since the mid-1970s to evaluate rotordynamic stability. The historical data accumulated by machinery manufacturers for successfully operated machines may conflict with the acceptance criteria of this specification. If such a conflict exists and a vendor can demonstrate that his stability analysis methods and acceptance criteria predict a stable rotor, then the vendor's criteria should be the guiding principle in the determination of acceptability.

Symbols

$$B_c = 3,$$

$$B_t = 1.5,$$

$$C = 9.55 \text{ (63)},$$

D_c = Impeller diameter, mm (in.),

D_t = Blade pitch diameter, mm (in.),

H_c = Minimum of diffuser or impeller discharge width per impeller, mm (in.),

H_t = Effective blade height, mm (in.),

HP = Rated power per stage or impeller, Nm/sec. (HP),

CSR = Critical speed ratio is defined as:

$$\text{CSR} = \frac{\text{Maximum Continuous Speed}}{\text{First Undamped Critical Speed on Rigid Supports (FCSR)}}$$

N = Operating speed, rpm,

Q_A = Anticipated cross coupling for the rotor, KN/mm (Klbf/in.) defined as:

$$Q_A = \sum_{i=1}^s q_{Ai}$$

Q_0 = Minimum cross coupling needed to achieve a log decrement equal to zero for either minimum or maximum component clearance,

q_A = Cross coupling defined in Equation 1.2-7 or 1.2-8 for each stage or impeller, KN/mm (Klbf/in.),

S = Number of stages or impellers,

δ_A = Minimum log decrement at the anticipated cross coupling for either minimum or maximum component clearance,

δ_b = Basic log decrement of the rotor and support system only,

δ_f = Log decrement of the complete rotor support system from the Level II analysis,

ρ_d = Discharge gas density per stage or impeller,

ρ_s = Suction gas density per stage or impeller,

ρ_{ave} = Average gas density across the rotor, kg/m³ (lbm/ft³).

Definitions

Stability analysis is the determination of the natural frequencies and the corresponding logarithmic decrements of

the damped rotor/support system using a complex eigenvalue analysis.

Synchronous tilt pad coefficients are derived from the complex frequency dependent coefficients with the frequency equal to the rotational speed of the shaft.

Stage refers to an individual turbine or axial compressor blade row.

Hysteresis or internal friction damping causes a phase difference between the stress and strain in any material under cyclic loading. This phase difference produces the characteristic hysteric loop on a stress-strain diagram and thus, a destabilizing damping force.

Minimum clearance for a tilt pad bearing occurs at the maximum preload condition. These can be calculated using the following formulas:

$$\text{Preload}_{\max} = 1 - \frac{\text{Bearing Radius}_{\min} - \text{Shaft Radius}_{\max}}{\text{Pad Bore}_{\max} - \text{Shaft Radius}_{\max}}$$

$$\text{Bearing Clearance}_{\min} = \text{Bearing Radius}_{\min} - \text{Shaft Radius}_{\max}$$

For maximum clearance at minimum preload:

$$\text{Preload}_{\min} = 1 - \frac{\text{Bearing Radius}_{\max} - \text{Shaft Radius}_{\min}}{\text{Pad Bore}_{\min} - \text{Shaft Radius}_{\min}}$$

$$\text{Bearing Clearance}_{\max} = \text{Bearing Radius}_{\max} - \text{Shaft Radius}_{\min}$$

2.6.7 Torsional Analysis

- **2.6.7.1** For motor-driven units and units including gears, units comprising three or more coupled machines (excluding any gears), or when specified, the vendor having unit responsibility shall ensure that a torsional vibration analysis of the complete coupled train is carried out and shall be responsible for directing any modifications necessary to meet the requirements of 2.6.7.2 through 2.6.7.6.

2.6.7.2 Excitation of torsional natural frequencies may come from many sources which may or may not be a function of running speed and should be considered in the analysis. These sources shall include but are not limited to the following:

- a. Gear characteristics such as unbalance, pitch line runout, and cumulative pitch error.
- b. Cyclic process impulses.
- c. Torsional transients such as start-up of synchronous electric motors and generator phase-to-phase or phase-to-ground faults.
- d. Torsional excitation resulting from electric motors, reciprocating engines, and rotary type positive displacement machines.
- e. Control loop resonance from hydraulic, electronic governors, and variable frequency drives.
- f. One and 2 times line frequency.

- g. Running speed or speeds.
- h. Harmonic frequencies from variable frequency drives.

2.6.7.3 The torsional natural frequencies of the complete train shall be at least 10% above or 10% below any possible excitation frequency within the specified operating speed range (from minimum to maximum continuous speed).

2.6.7.4 Torsional natural frequencies at two or more times running speeds shall preferably be avoided or, in systems in which corresponding excitation frequencies occur, shall be shown to have no adverse effect.

2.6.7.5 When torsional resonances are calculated to fall within the margin specified in 2.6.7.3 (and the purchaser and the vendor have agreed that all efforts to remove the critical from within the limiting frequency range have been exhausted), a stress analysis shall be performed to demonstrate that the resonances have no adverse effect on the complete train. The assumptions made in this analysis regarding the magnitude of excitation and the degree of damping shall be clearly stated. The acceptance criteria for this analysis shall be mutually agreed upon by the purchaser and the vendor.

2.6.7.6 In addition to the torsional analyses required in 2.6.7.2 through 2.6.7.5, the vendor shall perform a transient torsional vibration analysis for synchronous motor driven units, using a time-transient analysis. The requirements of 2.6.7.6.1 through 2.6.7.6.4 shall be followed.

2.6.7.6.1 In addition to the parameters used to perform the torsional analysis specified in 2.6.7.1, the following shall be included:

- a. Motor average torque, as well as pulsating torque (direct and quadrature axis) vs. speed characteristics.
- b. Load torque vs. speed characteristics.

Electrical system characteristics effecting the motor terminal voltage or the assumptions made concerning the terminal voltage including the method of starting, such as across the line, or some method of reduced voltage starting.

2.6.7.6.2 The analysis shall generate the maximum torque as well as a torque vs. time history for each of the shafts in the compressor train.

Note: The maximum torques shall be used to evaluate the peak torque capability of coupling components, gearing and interference fits of components such as coupling hubs. The torque vs. time history shall be used to develop a cumulative damage fatigue analysis of shafting, keys and coupling components.

2.6.7.6.3 Appropriate fatigue properties and stress concentrations shall be used.

2.6.7.6.4 An appropriate cumulative fatigue algorithm shall be used to develop a value for the safe number of starts.

The safe number of starts shall be as mutually agreed by the purchaser and vendor.

Note: Values used depend on the analytical model used and the vendor's experience. Values of 1000 – 1500 starts are common. API Std 541 requires 5000 starts. This is a reasonable assumption for a motor since it does not add significant cost to the design. The driven equipment, however, would be designed with overkill to meet this requirement. Example: 20-year life, 1 start/week = 1040 starts. Equipment of this type normally would start once every few years rather than once per week. A reasonable number of starts should therefore be specified.

2.6.8 Vibration and Balancing

2.6.8.1 Major parts of the rotating element, such as the shaft, balancing drum and impellers, shall be individually dynamically balanced before assembly, to ISO 1940 Grade G1 or better. When a bare shaft with a single keyway is dynamically balanced, the keyway shall be filled with a fully crowned half key, in accordance with ISO 8821. Keyways 180 degrees apart, but not in the same transverse plane, shall also be filled. The initial balance correction to the bare shaft shall be recorded. The components to be mounted on the shaft (impellers, balance drum, etc.), shall also be balanced in accordance with the "half-key-convention," as described in ISO 8821.

2.6.8.2 Unless otherwise specified, the rotating element shall be sequentially multiplane dynamically balanced during assembly. This shall be accomplished after the addition of no more than two major components. Balancing correction shall only be applied to the elements added. Minor correction of other components may be required during the final trim balancing of the completely assembled element. In the sequential balancing process, any half-keys used in the balancing of the bare shaft (see 2.6.8.1) shall continue to be used until they are replaced with the final key and mating element. On rotors with single keyways, the keyway shall be filled with a fully crowned half-key. The weight of all half-keys used during final balancing of the assembled element shall be recorded on the residual unbalance worksheet (see Annex 1B). The maximum allowable residual unbalance per plane (journal) shall be calculated as follows:

In SI units:

$$U_{\max} = 6350W/N \quad (1.2-9a)$$

or 250 μmm of mass eccentricity, whichever is greater.

In U.S. Customary units:

$$U_{\max} = 4W/N \quad (1.2-9b)$$

or 10 $\mu\text{in.}$ of mass eccentricity, whichever is greater.

where

U_{\max} = residual unbalance, in g-mm (oz.-in.),

W = journal static weight load, in kilograms (lb.),

N = maximum continuous speed, in rpm,

Mass eccentricity = $\frac{\text{Unbalance/Weight}}{[U/1000W (U/16W)]}$.

2.6.8.2.1 When the vendors standard assembly procedures require the rotating element to be disassembled after final balance to allow compressor assembly (i.e., stacked rotors with solid diaphragms and compressor/expanders), the vendor shall, as a minimum, perform the following operations:

- To insure the rotor has been assembled concentrically, the vendor shall take runout readings on the tip of each element (impeller or disc). The runout on any element shall not exceed a value agreed upon between the purchaser and the vendor.
- The vendor shall balance the rotor to the limits of 2.6.8.2, Equations 1.2-9a or 1.2-9b.
- The vendor shall provide historic unbalance data readings of the change in balance due to disassembly and reassembly. This change in unbalance shall not exceed 4 times the sensitivity of the balance machine. For this purpose, balance machine sensitivity is 10 $\mu\text{in.}$ maximum.
- The vendor shall conduct an analysis in accordance with 2.6.2, to predict the vibration level during testing, using an unbalance equal to that in item b, plus 2 times the average change in balance due to disassembly and reassembly as defined in item c. The results of this analysis shall show that the predicted vibration at design speed on test shall be no greater than 2 times the requirements of 2.6.8.8.
- After the rotor has been reassembled in the compressor case, the vibration during testing shall meet the limits as shown in 2.6.8.8.

Note: Trim balancing in the compressor case may be done to achieve this level.

- **2.6.8.2.1.1** When specified, the vendor shall record the balance readings after initial balance for the contract rotor. The rotor shall then be disassembled and reassembled. The rotor shall be check balanced after reassembly to determine the change in balance due to disassembly and reassembly. This change in balance shall not exceed that defined in 2.6.8.2.1c.
- **2.6.8.3** When specified, completely assembled rotating elements shall be subject to operating-speed (at speed) balancing in lieu of a sequential low speed balancing (see 2.6.8.2). When the vendor's standard balance method is by operating-speed balancing in lieu of a sequential low speed balancing and operating speed balancing is not specified, it may be used with the purchaser's approval. The operating-speed balance shall be in accordance with 2.6.8.4.

2.6.8.4 When the complete rotating element is to be operating-speed balanced (see 2.6.8.3), the rotor shall be supported in bearings of the same type and with similar dynamic characteristics as those in which it will be supported in service. The final check balance shall be carried out at maximum continuous speed. Before making any corrections (unless it is necessary to improve the initial balance in order to be able to run the rotor at high speed), the rotor shall be run, in the balancing machine at trip speed for at least 5 min., to allow seating of any shrunk-on components.

2.6.8.5 Unless otherwise specified, the vibration acceptance criteria for operating-speed balancing, with maximum pedestal stiffness at all speeds, measured on the bearing cap shall be as follows:

- For speeds above 3000 rpm: it shall not exceed the greater of 7400/ N mm/sec. (291 $N/\text{in.}/\text{sec.}$) or 1 mm/sec. (0.039 in./sec.), where N is the speed in rpm.
- For all speeds less than 3000 rpm: it shall not exceed 2.5 mm/sec. (0.098 in./sec.).

Note: This residual unbalance is at all speeds (includes any criticals), and the force from this residual unbalance is dependant on the pedestal stiffness and the measure velocity.

- **2.6.8.6** A rotor that is to be operating-speed balanced shall, when specified, first receive a sequential low speed balance as specified in 2.6.8.2.
- **2.6.8.7** For a rotor that has been low speed sequentially balanced (see 2.6.8.2), and when specified for rotors that are high-speed balanced (see 2.6.8.3), a low speed residual unbalance check shall be performed in a low speed balance machine and recorded in accordance with the residual unbalance worksheet (see Annex 1B).

Note: This is done to provide a reference of residual unbalance and phase for future use in a low speed balance machine.

2.6.8.8 During the mechanical running test of the machine, assembled with the balanced rotor, operating at its maximum continuous speed or at any other speed within the specified operating speed range, the peak-to-peak amplitude of unfiltered vibration in any plane, measured on the shaft adjacent and relative to each radial bearing, shall not exceed the following value or 25 μm (1 mil), whichever is less:

In SI units:

$$A = 25.4 \sqrt{\frac{12000}{N}} \quad (1.2-10a)$$

In U.S. Customary units:

$$A = \sqrt{\frac{12000}{N}} \quad (1.2-10b)$$

where

A = amplitude of unfiltered vibration, in μm (mil)
true peak-to-peak,

N = maximum continuous speed, in rpm.

At any speed greater than the maximum continuous speed, up to and including the trip speed of the driver, the vibration level shall not increase more than $12.7 \mu\text{m}$ (0.5 mil) above the maximum value recorded at the maximum continuous speed.

Note: These limits are not to be confused with the limits specified in 2.6.3 for shop verification of unbalanced response.

2.6.8.9 Electrical and mechanical runout shall be determined by rotating the rotor through the full 360 degrees supported in V blocks at the journal centers while continuously recording the combined runout with a non-contacting vibration probe and measuring the mechanical runout with a dial indicator at the centerline of each probe location and one probe-tip diameter to either side.

Note: The rotor runout determined above generally may not be reproduced when the rotor is installed in a machine with hydrodynamic bearings. This is due to pad orientation on tilt pad bearings and effect of lubrication in all journal bearings. The rotor will assume a unique position in the bearings based on the slow roll speed and rotor weight.

2.6.8.10 Accurate records of electrical and mechanical runout, for the full 360 degrees at each probe location, shall be included in the mechanical test report (see 2.6.3.1.1).

2.6.8.11 If the vendor can demonstrate that electrical or mechanical runout is present, a maximum of 25% of the test level calculated from Equation 1.2-8 or $6.5 \mu\text{m}$ (0.25 mil), whichever is greater, may be vectorially subtracted from the vibration signal measured during the factory test. Where shaft treatment such as metalized aluminum bands have been applied to reduce electrical runout, surface variations (noise) may cause a high frequency noise component which does not have an applicable vector. The nature of the noise is always additive. In this case, the noise shall be mathematically subtracted.

2.7 BEARINGS AND BEARING HOUSINGS

2.7.1 General

Radial and thrust bearings shall be as specified in the subsequent chapters of this specification.

2.7.2 Hydrodynamic Radial Bearings

Hydrodynamic radial bearings shall be in accordance with the applicable chapters of this specification.

2.7.3 Hydrodynamic Thrust Bearings

2.7.3.1 For gear couplings, the external thrust force shall be calculated from Equations 1.2-11a or 1.2-11b.

In SI units:

$$F = \frac{(0.25)(9550)P_r}{(N_r D)} \quad (1.2-11a)$$

In U.S. Customary units:

$$F = \frac{(0.25)(63,300)P_r}{(N_r D)} \quad (1.2-11b)$$

where

F = external thrust force, in kilonewtons (lb.),

P_r = rated power, in kW (HP),

N_r = rated speed, in rpm,

D = shaft diameter at the coupling, in mm (in.).

2.7.3.2 Thrust forces for flexible-element couplings shall be calculated on the basis of the maximum allowable deflection permitted by the coupling manufacturer.

2.7.3.3 If the thrust forces from two or more rotors are to be carried by one thrust bearing (such as in a gear box), the resultant of the forces shall be used, provided the directions of the forces make them numerically additive; otherwise, the largest of the forces shall be used.

2.7.3.4 The basis for the sizing of thrust bearings shall be provided.

2.7.4 Bearing Housings

2.7.4.1 Bearing housings shall be equipped with replaceable labyrinth-type end seals and deflectors where the shaft passes through the housing. Lip-type seals shall not be used. The seals and deflectors shall be made of spark-resistant materials. Seals and deflectors shall be designed to retain oil in the housing and prevent entry of foreign material into the housing.

2.7.4.2 Bearing housings shall be arranged to minimize foaming. The drain system shall be adequate to maintain the oil and foam level below shaft seals.

2.7.4.3 Oil connections on bearing housings shall be in accordance with 2.3.2.3.

2.7.4.4 Provisions for the installation of instrumentation per 3.4.7 of each chapter shall be provided.

2.7.4.5 Where practical, oil and instrument connections shall be in the lower half of the bearing housing to eliminate the need for removal during bearing inspections.

- **2.7.4.6** When specified, provisions for locally disconnecting bearing temperature sensors' wiring within the bearing housing shall be provided.

2.8 SHAFT END SEALS

2.8.1 General

- **2.8.1.1** Shaft seals shall be provided to restrict or prevent process gas leaks to the atmosphere or seal fluid leaks into the process gas stream over the range of specified operating conditions, including start-up and shutdown. Seals shall be suitable for specified variations in seal operating conditions that may prevail during start-up, shutdown, or settling out, and during any other special operation specified. The maximum sealing pressure shall be at least equal to the settling-out pressure. The shaft seals and seal system shall be designed to permit safe machine pressurization with the seal system in operation prior to process start-up.

Note: The purchaser should establish a realistic value for settling-out pressure. This may be the result of the relief valve setting on the suction drum. The value should be shown on the data sheets.

2.8.1.2 Typical cross sections of various types of shaft end seals are given in Annex 1C.

- **2.8.1.3** Shaft seals may be one or a combination of the types described in 2.8.2 through 2.8.4, as specified. The materials for component parts shall be suitable for the service.

2.8.1.4 Seal pressure equalizing lines and associated gas passages (including those for reference gas and axial thrust force balancing) shall be sized to maintain design shaft end seal performance at twice the maximum initial design clearances. The lines and passages shall also be sized to maintain minimal pressure drop through equalizing lines at all conditions including during acceleration.

- **2.8.1.5** The purchaser will specify whether buffer gas injection is to be used and, if so, the composition of that gas. In addition, the vendor shall state whether buffer gas injection is required for any specified operating conditions. The method of control will be specified by the purchaser.
- **2.8.1.6** When buffer gas is specified by the purchaser or required by the vendor, the vendor shall state the gas requirements, including pressures, flowrates, and filtration.
- **2.8.1.7** When specified, the vendor shall furnish the complete buffer gas control system including schematic and bill of material.

2.8.1.8 Equipment vendor shall be responsible for the satisfactory operation of the seal system and shall mutually work with the seal supplier and purchaser.

2.8.2 Clearance Seals

2.8.2.1 The labyrinth seal (see Figure 1.C-1 in Annex 1C) may include carbon rings, in addition to the labyrinths, if approved by the purchaser. Labyrinths may be stationary or rotating.

2.8.2.2 The restrictive-ring seal (a typical seal is shown in Figure 1.C-3 of Annex 1C) shall include rings of carbon or other suitable material mounted in retainers or in spacers. The seal may be operated dry, or with a sealing liquid, or with a buffer gas.

- **2.8.2.3** Eductors or injection systems, when specified, shall be furnished complete with piping, regulating and control valves, pressure gauges, and strainers. Each item shall be piped and valved to permit its removal during operation of the compressor. Where gas from the compressor discharge is used for the motivating power of the eductor, provisions must be made for sealing during start-up and shutdown.
- **2.8.2.4** When specified, for compressors with sub atmospheric pressure at the shaft end seals, provision shall be made to pressurize the seal(s) with gas at a pressure that is higher than atmospheric.

2.8.3 Oil Seals

2.8.3.1 Shaft end oil seal(s) shall be provided with provision(s) to internally pressurize these seals with gas at a pressure that is higher than atmospheric.

2.8.3.2 For any shaft end seals using sealing liquid, the inward leakage from each seal shall be piped to an independent drain pot. No individual shaft end seal shall have a leakage rate greater than 70% of the total expected leakage from all shaft seals in a single machine.

2.8.3.3 Seal oil contaminated by the process gas that would damage components such as bearings, seal rings, O-rings, and couplings shall be piped away separately to allow disposal or reconditioning.

- **2.8.3.4** The mechanical (contact) seal (a typical seal is shown in Figure 1.C-2 of Annex 1C) shall be provided with labyrinths and slingers. Oil or other suitable liquid furnished under pressure to the rotating seal faces may be supplied from the lube-oil system or from an independent seal system. Mechanical seals shall be designed to minimize gas leaks while the compressor is pressurized and being shut down and after it is stopped in the event of seal-oil failure. Various supplemental devices may be provided to ensure sealing when the compressor is pressurized but not running and the seal-oil system is shut down. The purchaser will specify whether such a device is to be provided. The final design shall be mutually agreed upon by the purchaser and the vendor.

2.8.3.5 The liquid-film seal (typical seals are shown in Figures 1.C-4 and 1.C-5 of Annex 1C) shall be provided with sealing rings or bushings and labyrinths. A sealing liquid shall be supplied. Liquid-film seals may be cylindrical-bushing seal as shown in Figure 1.C-4, or pumping seals as shown in Figure 1.C-5. Unless otherwise specified, an elevated tank shall be provided with the required static head to overcome system pressure losses (such as friction losses in internal passages and seal-oil piping) and maintain positive sealing pressure. The vendor shall state the height of the tank above the compressor centerline. Other means to maintain this differential pressure and positive seal may be used with the purchaser's approval.

2.8.3.6 Seal-oil systems shall be in accordance with API Std 614, Chapters 1 and 2 (Special Purpose Oil Systems).

2.8.4 Self-acting Dry Gas Seal

2.8.4.1 The self-acting dry gas seal may be a single, tandem, triple or double configuration depending on the application. The self-acting dry gas seal requires external seal gas but does not require any liquid for lubrication or cooling. Typical configurations are shown in Figures 1.C-6, 1.C-7, 1.C-8, and 1.C-9 of Annex 1C. Where toxic or flammable seal gases are used, an isolating seal is required to prevent uncontrolled leaks to the atmosphere or to the bearing housing. This isolating seal shall preferably be capable of acting as a backup seal should the primary seal fail during operation. The seal gas shall be filtered and shall be free of any contaminants that form residues. The seal gas source may be taken from the compressor discharge or inter-stage point. An alternate seal gas source may be used, and may be required during start-up or shutdown. The design of the gas seal support system is detailed in API Std 614.

Note 1: Caution should be exercised if air is used as a purge or buffer gas to insure that explosive mixtures are not created when air is mixed with the seal outer leakage consisting of process gas.

Note 2: Other variations are commonly used depending on the particular application. The seal will leak a small amount of seal gas, and may be unidirectional in operation. For testing considerations at the seal manufacturer's shop for this type of seal, see Annex 1D.

Note 3: If liquids may be formed or are present in the sealing gas, then coalescing filters and condensate traps may be required in the seal support module (see API Std 614, Chapter 4, 2.3.5 and 2.5).

2.8.4.2 Self-acting dry gas seals shall be provided with connections to allow the user to inject filtered gas, and to protect against reversal of differential pressure during sub-atmospheric operation.

Note: Some self-acting dry gas seals can be destroyed by reversal of pressure differential.

Clean filtered gas is required due to tight clearances of these seals. This may even be required on the inboard side of a double seal to prevent migration of particles through the seal face.

2.8.4.3 Seal support systems for self-acting dry gas seals shall be in accordance with API Std 614, Chapters 1 and 4.

2.8.4.4 Each dry gas seal assembly, regardless of its arrangement, shall be cartridge mounted and positively located and attached to the compressor shaft. For uni-directional seals, cartridges shall be designed so the incorrect installation of the cartridges is impossible.

2.9 GEARS

For integral gears, see Chapter 3. For separate gear units, see 3.1.8.

2.10 LUBRICATION AND SEALING SYSTEMS

2.10.1 If required, a pressurized oil system or systems shall be furnished to supply oil at a suitable pressure or pressures, as applicable, to the following:

- The bearings of the driver and of the driven equipment (including any gear).
- The continuously lubricated couplings.
- The governing and control-oil system.
- The shaft seal-oil system.
- The purchaser's control system (if hydraulic).

2.10.2 Housings that enclose moving lubricated parts (such as bearings and shaft seals), highly polished parts, instruments, and control elements shall be designed to minimize contamination by moisture, dust, and other foreign matter during periods of operation or idleness.

2.10.3 Unless otherwise specified, pressurized oil systems shall conform to the requirements of API Std 614, Chapters 1 and 2.

Note: Expander-compressors utilize pressurized bearing housings and reservoirs. These details are covered in Chapter 4, 2.10.

2.11 NAMEPLATES AND ROTATION ARROWS

Information regarding nameplates and rotational arrows may be found in the subsequent chapters for the equipment being addressed.

2.11.1 A nameplate shall be securely attached at a readily visible location on the equipment and on any major piece of auxiliary equipment.

2.11.2 Nameplates and rotation arrows (if attached) shall be of austenitic stainless steel or nickel-copper (UNS N04400) alloy. Attachment pins shall be of the same material. Welding is not permitted.

2.12 QUALITY

Refer to API RP 683 for guidelines to improve the quality of the equipment.

SECTION 3—ACCESSORIES

3.1 DRIVERS

3.1.1 The driver shall be of the type specified, sized to meet the maximum specified operating conditions, including external gear or coupling losses, and shall be in accordance with applicable specifications. The driver(s) shall operate under the utility and site conditions specified by the inquiry.

3.1.2 The driver shall be sized to accept any specified process variations such as changes in the pressure, temperature, or properties of the fluids handled and plant start-up conditions.

3.1.3 The driver shall be capable of starting under the process and utility conditions specified. The starting method and worst case starting torque requirements shall be mutually agreed. The driver's starting-torque capabilities shall exceed the speed-torque requirements of the machine train.

3.1.4 Steam turbine drivers shall conform to ISO 10437 (API Std 612). Steam turbine drivers shall be sized to deliver continuously not less than 110% of the maximum power required by the machine train, when operating at any of the specified operating conditions, and specified normal steam conditions.

Note: The 110% applies to the design phase of the project. After testing, this margin may not be available due to performance tolerances of the driven equipment.

3.1.5 Motor drives shall conform to internationally recognized standards such as API Std 541 or API Std 546, as applicable. (Motors that are below the power scope of API Std 541 or API Std 546 shall be in accordance with IEEE 841.) Electric motor drivers shall be rated with a 1.0 S.F. The motor rating shall be at least 110% of the greatest power required (including gear and coupling losses) for any of the specified operating conditions. Consideration shall be given to the starting conditions of both the driver and driven equipment and the possibility that these conditions may be different from the normal operating conditions.

Note: The 110% applies to the design phase of a project. After testing, this margin might not be available due to performance tolerances of the driven equipment.

3.1.6 The motor's starting-torque requirements shall be met at a reduced voltage specified by the purchaser, and the motor shall accelerate to full speed within a time period

agreed upon by the purchaser and the vendor. Unless otherwise specified, starting voltage is 80% of the normal voltage.

Note: For most applications, with starting voltage of 80% of the normal voltage, and the time required to accelerate to full speed is generally less than 30 sec. During this time, the electrical system voltage will recover to normal voltage levels.

3.1.7 Gas turbine drivers shall conform to API Std 616 and shall be sized as mutually agreed upon by the purchaser and the vendor taking account of site conditions, particularly variations in ambient air temperature.

3.1.8 Separate gear units shall be in accordance with API Std 613. Epicyclic gears may be used with the purchaser's approval.

3.2 COUPLINGS AND GUARDS

3.2.1 Unless otherwise specified, flexible couplings and guards between drivers and driven equipment shall be supplied by the manufacturer of the driven equipment.

3.2.2 Couplings, coupling to shaft junctures, and coupling guards shall conform to API Std 671. The make, type, and mounting arrangement of the coupling shall be agreed upon by the purchaser and the vendor with unit responsibility of the driver and driven equipment.

3.2.3 The machine vendor shall arrange for mounting of all couplings hubs.

3.2.4 The purchaser of the coupling shall provide or include a moment simulator, as required for the mechanical running test.

- **3.2.5** When specified, the machine vendor shall provide plug and ring gauges in accordance with API Std 671, Appendix D.

3.2.6 When hydraulically fitted couplings are provided, the machine vendor shall provide all necessary mounting tools to hydraulically remove and install each coupling. The tools shall include a pusher, dilator, hydraulic pump and necessary hoses and fittings. Preferably, a common mounting fixture will be used for all couplings within the train.

3.2.7 Coupling guards shall be supplied in accordance with API Std 671, Appendix E.

3.3 MOUNTING PLATES

3.3.1 General

- **3.3.1.1** The equipment shall be furnished with soleplates or a baseplate, as specified.

3.3.1.2 Mounting plates (baseplates and soleplates) shall comply to the requirements of 3.3.1.2.1 through 3.3.1.2.17.

3.3.1.2.1 Mounting plates shall be furnished with horizontal (axial and lateral) jackscrews. The lugs holding these jackscrews shall be attached to the mounting plates in such a manner that they do not interfere with the installation of the equipment, jackscrews or shims. Means for moving the equipment vertically for removal or insertion of shims shall be provided. Precautions shall be taken to prevent vertical jackscrews (if provided) in the equipment feet from marring the shimming surfaces. Alternative methods of lifting the equipment for the removal or insertion of shims or for moving the equipment horizontally, such as provision for the use of hydraulic jacks, may be proposed. Such arrangements should be proposed for equipment that is too heavy to be lifted or moved horizontally using jackscrews. Alignment jackscrews shall be plated for rust resistance.

3.3.1.2.2 Alignment shims shall be in accordance with API RP 686, Chapter 7 and shall straddle hold down bolts and vertical jackscrews and shall be at least 5 mm ($1/4$ in.) larger on all sides than the equipment feet.

3.3.1.2.3 All machinery mounting surfaces on the mounting plate shall be machined flat and parallel to the axial plane(s) of the machinery mounting feet after fabrication and shall extend at least 25 mm (1 in.) beyond the outer three sides of the equipment feet.

These mounting surfaces shall meet the following requirements:

1. Each mounting surface shall be machined to a finish of $6\ \mu\text{m}$ ($250\ \mu\text{in.}$) arithmetic average roughness (Ra) or better.
2. To prevent a soft foot, when the machine is installed on the mounting plate, all mounting surfaces in the same horizontal plane shall be within $25\ \mu\text{m}$ (0.001 in.).
3. Each mounting surface shall be machined within a flatness of $13\ \mu\text{m}$ per 330 linear mm (0.0005 in. per linear ft) of mounting surface.
4. Different mounting planes shall be parallel to each other within $50\ \mu\text{m}$ (0.002 in.).
5. Hold-down bolt holes shall be drilled perpendicular to the mounting surfaces, machined or spot faced to a diameter suitable for a fully eccentric washer next to the hole to allow for equipment alignment. The hole shall be 15 mm ($1/2$ in.) larger in diameter than the hold down bolt.

3.3.1.2.4 Machinery mounting plates and supports shall be designed to have sufficient strength and rigidity to limit cou-

pling movement caused by imposing allowable forces and moments to $50\ \mu\text{m}$ (0.002 in.).

3.3.1.2.5 When centerline supports are provided, they shall be designed and manufactured to permit the machine to be moved using horizontal jackscrews.

3.3.1.2.6 Unless otherwise specified, anchor bolts will be furnished by the purchaser.

3.3.1.2.7 Anchor bolts shall not be used to fasten machinery to the mounting plates.

3.3.1.2.8 Grouted mounting plates shall be adequately sized to limit the static loading to 100 psi on the grout.

3.3.1.2.9 Diametrical clearance between anchor bolts and the anchor bolt holes in the mounting plates shall be a minimum of 6 mm ($1/4$ in.).

This is required to provide a method to do field leveling of the baseplate or the soleplates. It is not the equipment feet.

3.3.1.2.10 Unless otherwise specified, mounting plates shall be supplied with vertical leveling screws for field leveling. A leveling screw shall be provided near each anchor bolt. If the equipment and mounting plates are too heavy to be lifted using leveling screws, alternate methods shall be provided by the equipment vendor. The design of the alternate method shall be included in the proposal.

3.3.1.2.11 Mounting plate surfaces that are to be grouted to concrete shall have 50 mm radiused (2 in. radiused) minimum outside corners (in the plan view). See Figures 1.3-1, 1.3-2, 1.3-3 and 1.3-4.

3.3.1.2.12 Machinery hold down bolts and fasteners for attaching the equipment to the mounting shall be provided by the equipment vendor.

3.3.1.2.13 When the machine is properly aligned on the mounting plate in the shop, each hold-down bolt shall have a minimum clearance of 1.5 mm ($1/16$ in.) between the bolt and the bolt hole.

Note: Hold-down bolts need adequate clearance within the bolt holes so the machinery can be moved laterally during final field alignment without becoming bolt bound.

3.3.1.2.14 Adequate working clearance shall be provided at the bolt locations to allow the use of standard socket or box wrenches and to allow the equipment to be moved using the horizontal and vertical jackscrews.

3.3.1.2.15 Unless otherwise specified, the equipment vendor shall prepare the mounting plates by commercially abrasive blasting all grout contacting surfaces in accordance with ISO 8501 Grade Sa2 (SSPC SP 6) and shall precoat these surfaces with an inorganic zinc silicate in preparation for epoxy grout.

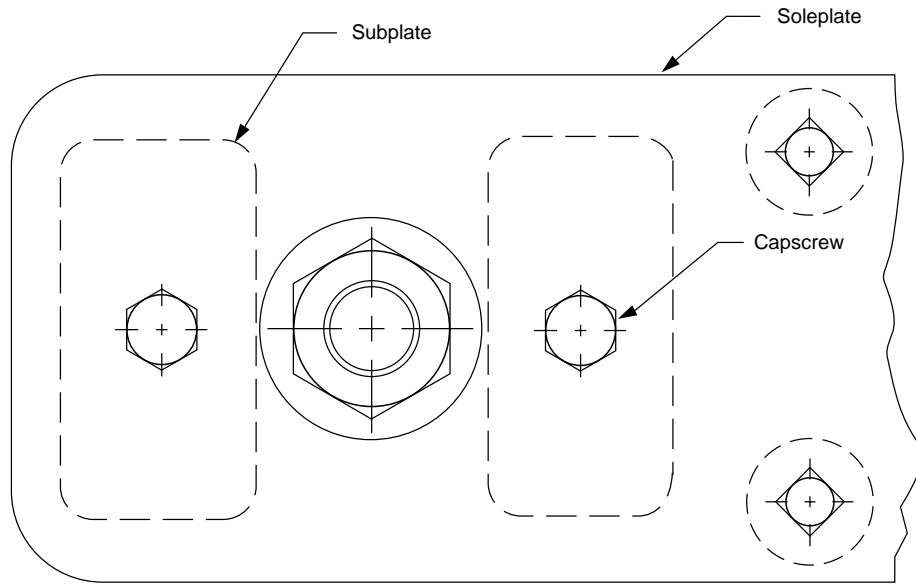

TOP VIEW OF FOUNDATION AT FOUNDATION BOLT

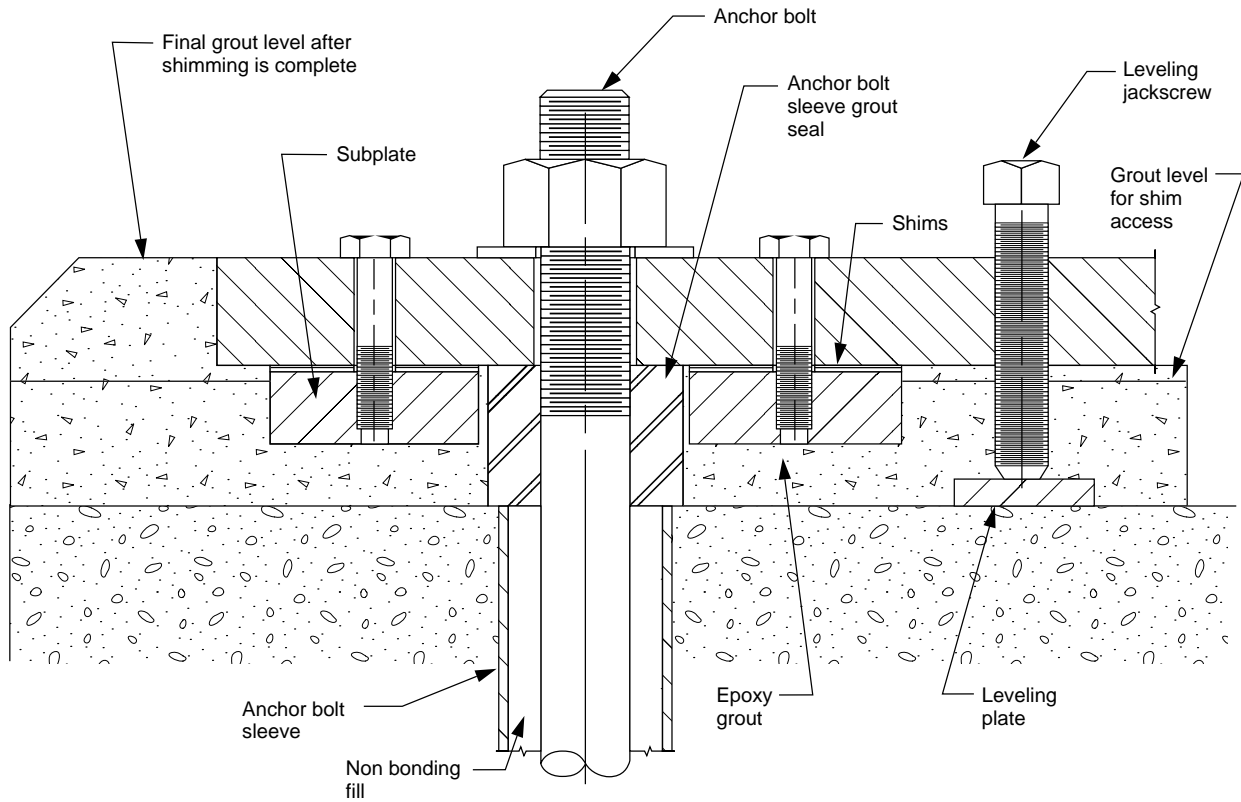

CROSS-SECTION OF FOUNDATION AT FOUNDATION BOLT

Figure 1.3-1—Typical Mounting Plate Arrangement

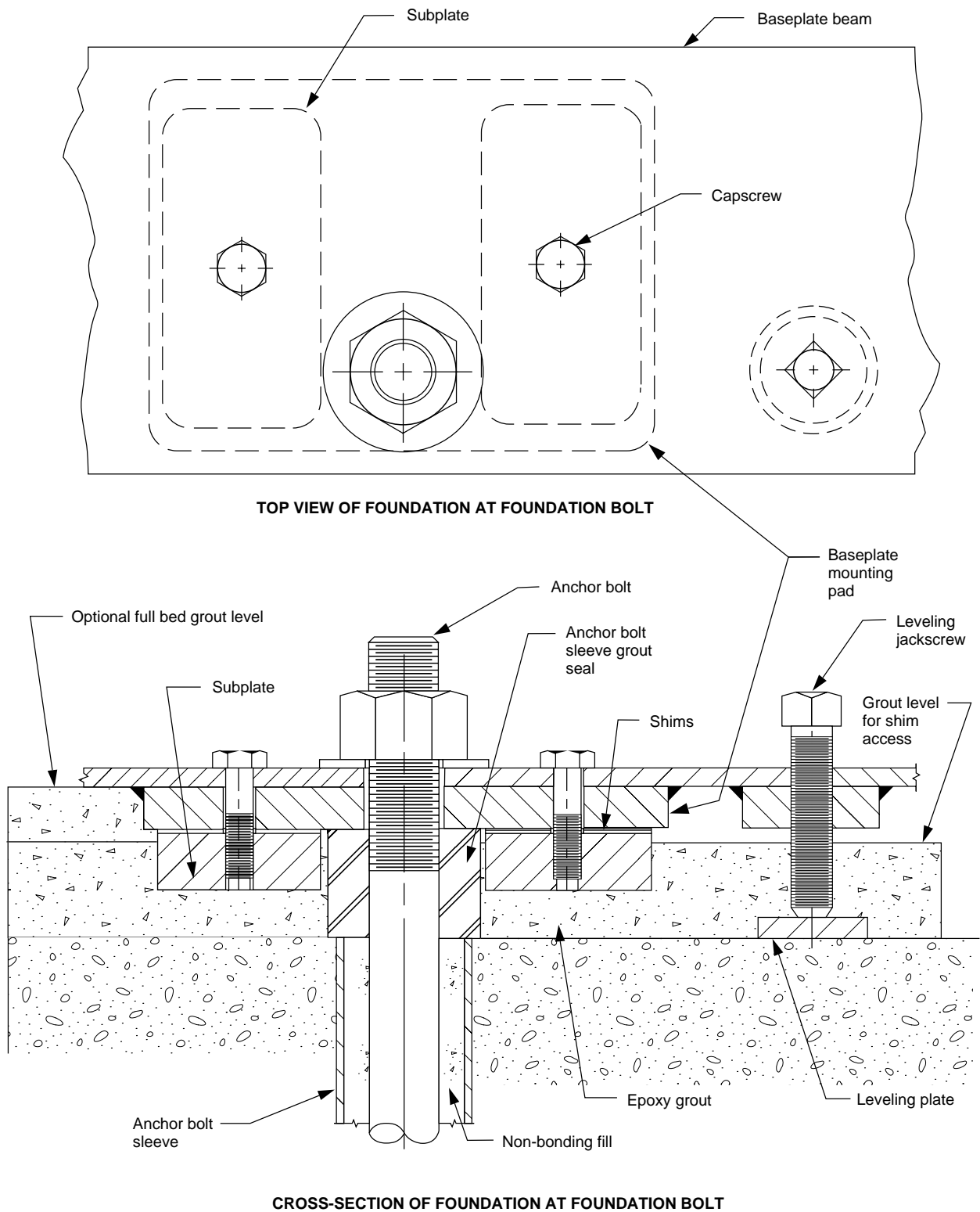
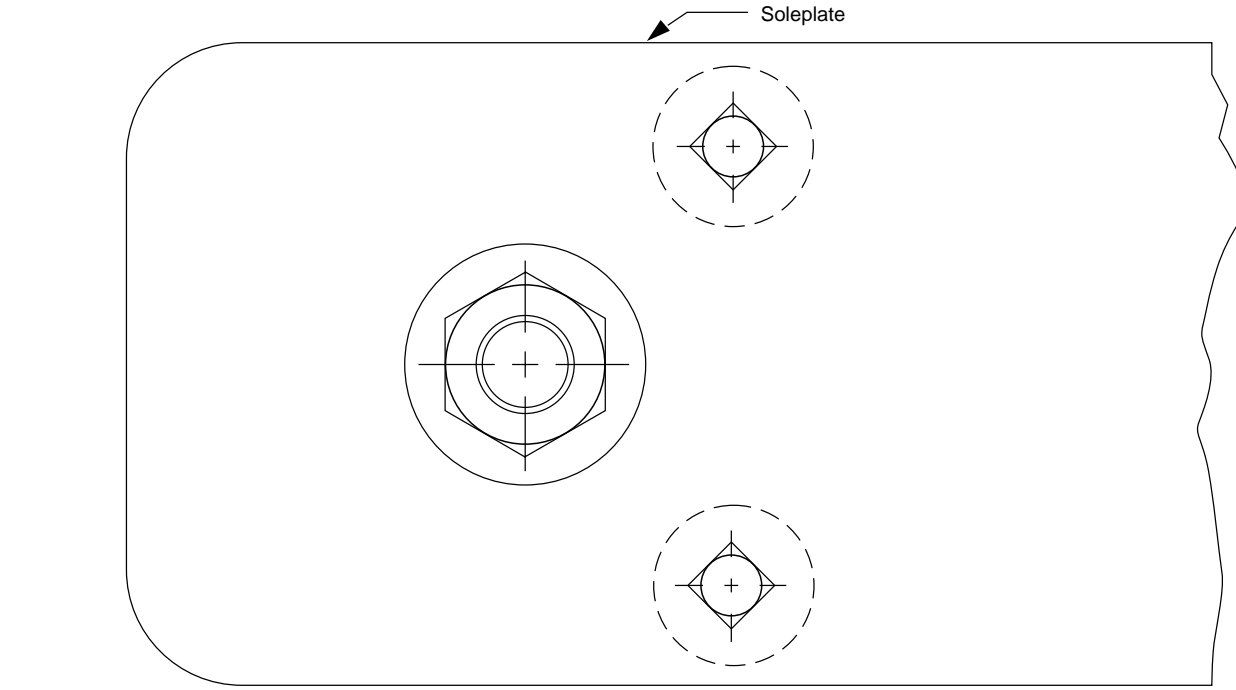
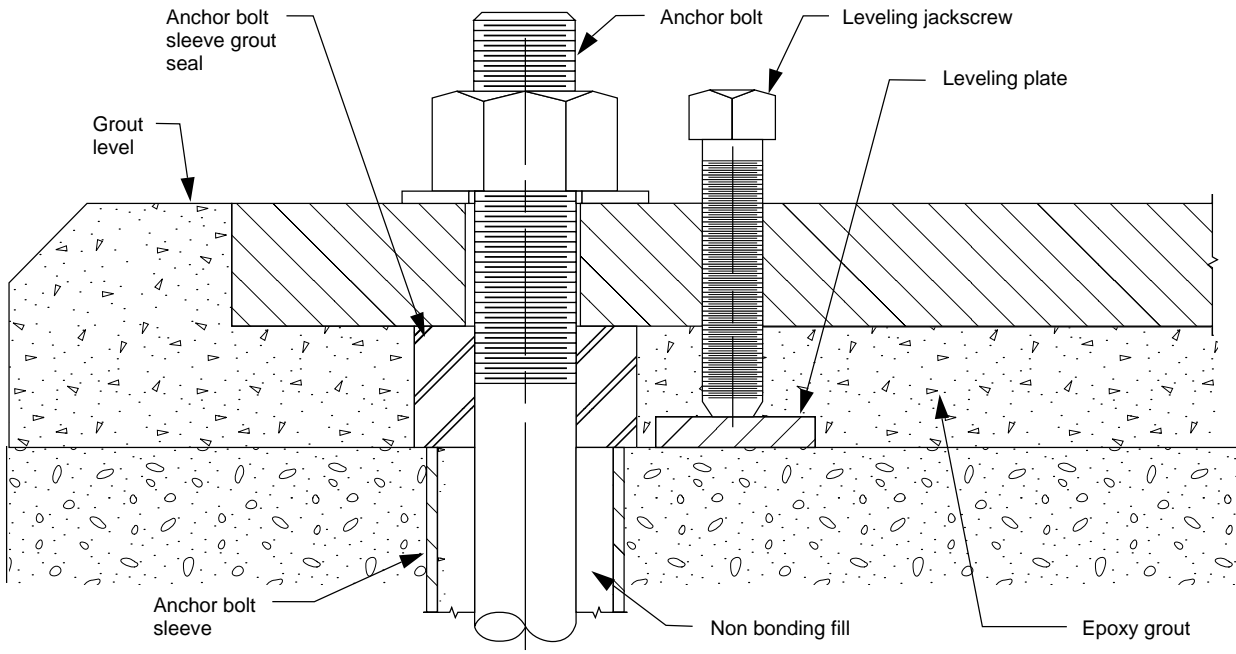

Figure 1.3-2—Typical Mounting Plate Arrangement



TOP VIEW OF FOUNDATION AT FOUNDATION BOLT



CROSS-SECTION OF FOUNDATION AT FOUNDATION BOLT

Figure 1.3-3—Typical Mounting Plate Arrangement

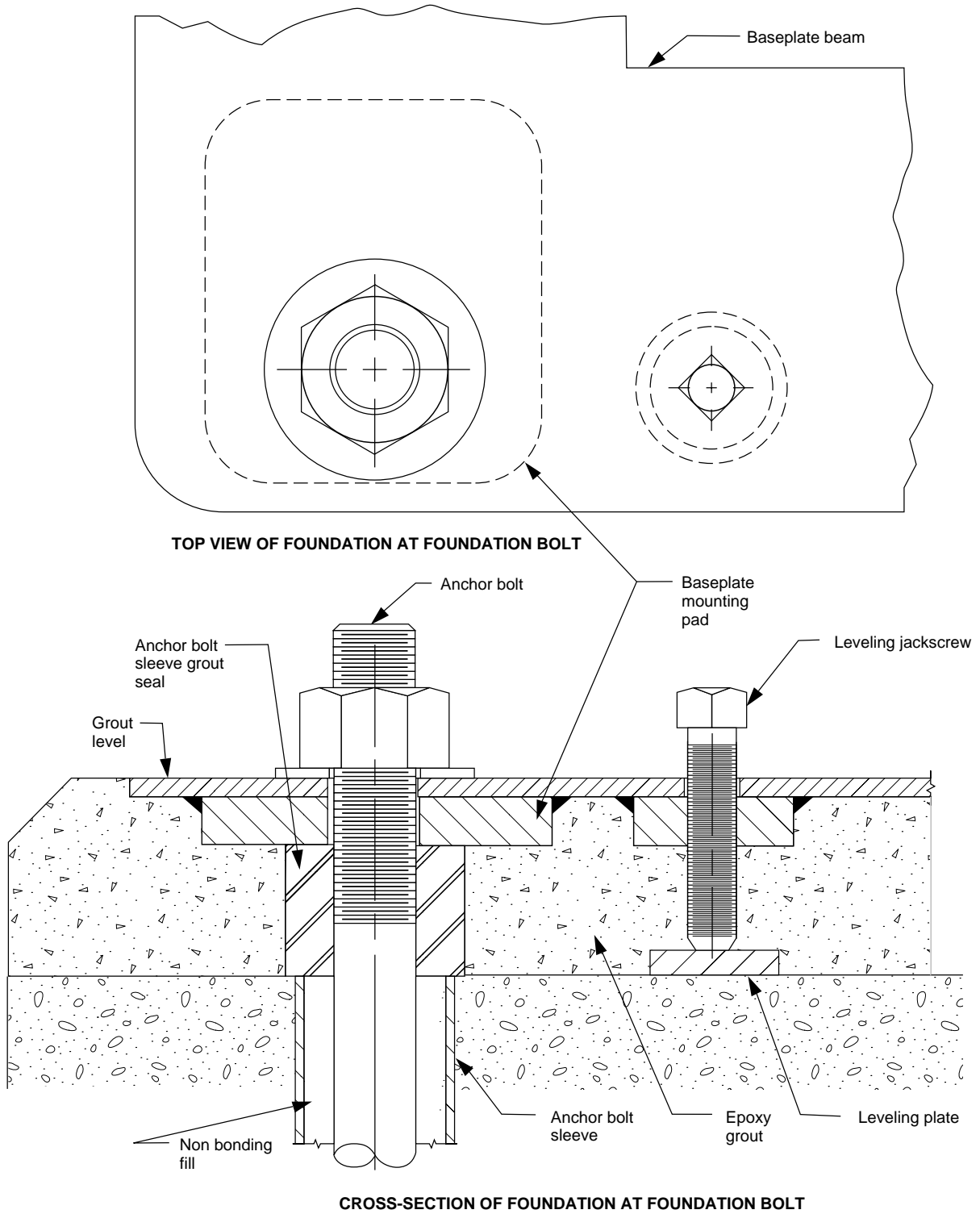

Figure 1.3-4—Typical Mounting Plate Arrangement

Note: Inorganic zinc silicate is compatible with epoxy grout, does not exhibit limited life after application as does most epoxy primers and is environmentally acceptable.

3.3.1.2.16 All mounting surfaces that are not to be grouted shall be coated with a rust preventive immediately after machining.

3.3.1.2.17 Unless otherwise specified, mounting plates shall not be drilled for components to be mounted by others.

3.3.2 Baseplates

- **3.3.2.1** When a baseplate is specified, the purchaser will indicate the major equipment to be mounted on it. A baseplate shall be a single fabricated steel unit, unless the purchaser and the vendor mutually agree that it may be fabricated in multiple sections. Multiple-section baseplates shall have machined and doweled mating surfaces which shall be bolted together to ensure accurate field reassembly.

Note: A baseplate with a nominal length of more than 12 m (40 ft) or a nominal width of more than 4 m (12 ft) may have to be fabricated in multiple sections because of shipping restrictions.

3.3.2.2 Unless otherwise specified, the underside mounting surfaces of the baseplate shall be in one plane to permit use of a single-level foundation.

3.3.2.3 All baseplate structural welds shall be continuous. Skip welding and crevices are not permitted.

- **3.3.2.4** When specified, nonskid decking or grating covering all walk and work areas shall be provided on the top of the baseplate.

Note: If, after grouting, the purchaser plans to completely fill the baseplate with cement as a finished surface, decking or grating is not required.

- **3.3.2.4.1** When specified, horizontal solid decked surfaces shall be sloped to avoid collection of water.
- **3.3.2.5** When specified, the baseplate shall be designed for mounting on structural columns and shall be sufficiently rigid without continuous grouting. The purchaser and the vendor shall mutually agree on the baseplate design.
- **3.3.2.6** When specified, the baseplate shall be designed to facilitate the use of optical, laser or other instruments for field leveling during installation. Design details are described in 3.3.2.6.1 to 3.3.2.6.3. The purchaser and the vendor shall mutually agree the final design.

3.3.2.6.1 When leveling pads or targets are provided, the pads or targets shall be accessible for field leveling with the equipment mounted and the baseplate on the foundation. The leveling pads and targets shall have protective removable covers.

3.3.2.6.2 For column mounted baseplates, leveling pads and targets shall be located close to support points.

3.3.2.6.3 For non-column mounted baseplates, leveling pads and targets shall be, as minimum, located at each corner. For baseplates longer than 6 m, additional pads and targets shall be provided at intermediate points.

3.3.2.7 The baseplate shall be provided with lifting lugs for at least a four-point lift. Lifting the baseplate complete with all equipment mounted shall not permanently distort or otherwise damage the baseplate or the equipment mounted on it.

3.3.2.8 When the baseplate is intended to be grouted onto a concrete foundation, adequate access shall be provided into each compartment so all load carrying structural members can be properly grouted. Decking or grating must be removable for access to internal structural members.

- **3.3.2.9** When specified, the bottom of the baseplate shall have machined mounting pads. These pads shall be machined in a single plane after the baseplate is fabricated.

Note: These machined mounting pads are necessary when the baseplate is mounted on sub-soleplates or structural steel members to facilitate field leveling.

- **3.3.2.10** When specified, sub-sole plates shall be provided by the vendor.
- 3.3.2.11** Unless otherwise specified, oil reservoirs shall be separate from the baseplate.

3.3.3 Soleplates and Subsoleplates

- **3.3.3.1** When soleplates are specified, they shall meet the requirements of 3.3.3.1.1 through 3.3.3.1.4.

3.3.3.1.1 Soleplates shall be steel plates that are thick enough to transmit the expected loads from the equipment feet to the foundation, but in no case shall the plates be less than 40 mm (1¹/₂ in.) thick.

- **3.3.3.1.2** Soleplates shall be large enough to extend beyond the feet of the equipment in all directions and shall be designed such that the anchor bolts are not covered by machine feet. When specified, anchor bolt holes shall be counterbored so that the hold-down nuts do not extend beyond the upper surface of the soleplate.
- **3.3.3.1.3** When specified, sub-sole plates shall be provided by the vendor.

3.3.3.1.4 When subsoleplates are used, soleplates shall be fully machined top and bottom.

3.3.3.1.5 When subsoleplates are specified, they shall be steel plates at least 25 mm (1 in.) thick. The finish of the subsoleplates' mating surfaces shall match that of the soleplates.

3.4 CONTROLS AND INSTRUMENTATION

3.4.1 General

- **3.4.1.1** The vendor shall provide sufficient machine performance data (in accordance with Section 5) to enable the purchaser to properly design a control system for start-up operation, for all specified operating conditions, and for surge prevention. When specified, the vendor shall review the purchaser's overall machine control system for compatibility with vendor-furnished control equipment.

3.4.1.2 Unless otherwise specified, instrumentation and installation shall conform to the requirements of API Std 614, Chapter 1.

3.4.1.3 Unless otherwise specified, locally mounted controls and instrumentation shall be designed for outdoor installation.

3.4.1.4 Instrumentation and controls shall be designed and manufactured for use in the area classification (class, group, and division or zone) specified by the purchaser and shall comply with any local codes and regulations.

3.4.1.5 All conduit, armored cable and supports shall be designed and installed so that it can be easily removed without damage and shall be located so that it does not hamper removal of bearings, seals, or equipment internals.

3.4.2 Control Systems

- **3.4.2.1** The purchaser will specify the method of control, the source of the control signal, its sensitivity and range, and the equipment to be furnished by the vendor. When specified, the vendor shall review the purchaser's control system.

Note: Compressor control may be accomplished by suction throttling, variable inlet guide vanes, variable stator vanes, speed variation, a cooled bypass from discharge to suction, discharge blowoff or discharge throttling.

- **3.4.2.2** When specified, an anti-surge system shall be provided.

Note: Anti-surge systems are generally required to prevent operating in unstable regions which may cause damage to the compressor. The scope of supply for these systems is process dependent and should be mutually determined.

3.4.3 Instrument and Control Panels

Refer to API Std 614 for details on instrument and control panels.

3.4.4 Instrumentation

Refer to API Std 614 for details on instrumentation, and API Std 670 for details on installation.

3.4.5 Alarms and Shutdowns

Refer to Chapters 1 and 2 of API Std 614.

3.4.6 Electrical Systems

Refer to Chapters 1 and 2 of API Std 614.

3.4.7 Vibration, Position, and Bearing Temperature Detectors

Vibration, position, and bearing temperature detectors will be covered in 3.4.7 of each subsequent chapter.

3.5 PIPING AND APPURTENANCES

3.5.1 General

3.5.1.1 Auxiliary piping supplied by the vendor shall be in accordance with Tables 1 and 2 of Chapter 1 of Std API 614.

3.5.1.2 Auxiliary systems furnished shall be in accordance with API Std 614, Chapters 1 and 2 (Special Purpose Oil Systems), Chapters 1 and 3 (General Purpose Oil Systems) and Chapters 1 and 4 (Dry Gas Seal Module Systems), as specified in the subsequent chapters of this standard. Other systems, if furnished shall be mutually agreed upon.

3.5.1.3 Auxiliary systems include piping systems that are in the following services:

- Instrument and control air.
- Lubricating oil.
- Control oil.
- Seal fluid.
- Cooling water.
- Balance gas.
- Reference gas.
- Buffer gas.
- Drains and vents
- Liquid injection.

Note: Casing connections are discussed in 2.3.2.

3.5.1.4 Auxiliary piping to the machine shall have break-out spools to allow for maintenance and for removal of the entire machine. Provision for bypassing the bearings (and seals if applicable) of machines and drivers during oil system flushing operations shall be provided. Unless otherwise specified, these spools shall be furnished by the equipment vendor.

Note: Generally this is accomplished by short spool pieces at the equipment.

3.5.2 Instrument Piping

Instrument piping, if furnished, shall be in accordance with Chapters 1 and 2 of API Std 614.

3.5.3 Process Piping

Process piping, if furnished, shall be in accordance with 2.4 of Chapter 1 of API Std 614.

3.6 SPECIAL TOOLS

3.6.1 When special tools and fixtures are required to disassemble, assemble, or maintain the unit, they shall be included in the quotation and furnished as part of the initial supply of the machine. For multiunit installations, the requirements for

quantities of special tools and fixtures shall be mutually agreed upon. These or similar special tools shall be used during shop assembly and post-test disassembly of the equipment.

Note: Special tools are tools which are not commercially available catalog items.

3.6.2 When special tools are provided, they shall be packaged in separate, rugged boxes and marked "Special tools for (tag/item number)." Each tool shall be stamped or tagged to indicate its intended use.

SECTION 4—INSPECTION, TESTING, AND PREPARATION FOR SHIPMENT

4.1 GENERAL

4.1.1 After advance notification of the vendor by the purchaser (see 4.1.4), the purchaser's representative shall have entry to all vendor and subvendor plants where manufacturing, testing, or inspection of the equipment is in progress.

4.1.2 The vendor shall notify subvendors of the purchaser's inspection and testing requirements.

4.1.3 The vendor shall provide sufficient advance notice to the purchaser before conducting any inspection or test that the purchaser has specified to be witnessed or observed.

- **4.1.4** The purchaser will specify the extent of his participation in the inspection and testing.

4.1.4.1 The purchaser and the vendor shall meet to coordinate manufacturing hold points and inspectors' visits.

4.1.5 Any equipment required for the specified inspection and tests shall be provided by the vendor.

- **4.1.6** When specified, the purchaser's representative, the vendor's representative or both shall indicate compliance in accordance with the inspector's checklist (Annex D of the applicable chapter) by initialing, dating, and submitting the completed form before shipment.

4.1.7 The purchaser's representative shall have access to the vendor's quality control program for review.

4.2 INSPECTION

4.2.1 General

The vendor shall keep the following data available for examination by the purchaser or his representative upon request for at least 5 years:

- a. Necessary certification of materials, such as mill test reports.
- b. Purchase specifications for all items on bills of materials.

c. Test data to verify that the requirements of the specification have been met.

d. Fully identified records of all heat treatment, whether performed in the normal course of manufacture or as part of a repair procedure.

e. Results of quality-control tests and inspections.

f. Running test data (see 4.3.6).

g. Final-assembly maintenance and running clearances.

4.2.1.1 Pressure-containing parts shall not be painted until the specified hydrotest of the parts is completed. When a helium leak test after hydrotest but before final assembly is specified, this requirement shall also apply.

4.2.1.2 The purchaser will specify the following:

a. Parts that shall be subject to surface and subsurface examination.

b. The type of examination required, such as magnetic particle, liquid penetrant, radiographic, or ultrasonic examination.

4.2.1.3 During assembly of the machine and before testing, each component (including cast in passages of these components) and all piping and appurtenances shall be cleaned by pickling or by another appropriate method to remove foreign materials, corrosion products, and mill scale.

4.2.1.4 When specified, the purchaser may inspect the equipment and all piping and appurtenances furnished by or through the vendor, for cleanliness, before heads are welded to vessels, openings in vessels or exchangers are closed, or piping is finally assembled.

4.2.1.5 When specified, the hardness of parts, welds, and heat-affected zones shall be verified as being within the allowable values by testing of the parts, welds, or heat-affected zones. The method, extent, documentation, and witnessing of the testing shall be mutually agreed upon by the purchaser and the vendor.

4.2.2 Material Inspection

4.2.2.1 General

When radiographic, ultrasonic, magnetic particle, or liquid penetrant inspection of welds or materials is specified, the recommended practices in 4.2.2.2 through 4.2.2.5 shall apply unless other procedures are specified by the purchaser. Cast iron may be inspected in accordance with 4.2.2.4 and 4.2.2.5. Welds, cast steel, and wrought material may be inspected in accordance with 4.2.2.2 through 4.2.2.5. The material inspection of pressure-containing parts is covered in 2.3.1.12; impellers, in 2.5.10.

Note: These recommended practices describe examination techniques that are applicable to great varieties of sizes and shapes of materials and widely varying examination requirements. Since the specification for the actual component being inspected depends on metallurgy, component configuration, and method of manufacture, specific procedures and acceptance standards for the application should be covered by written standards, developed by the manufacturer for the specific application.

4.2.2.1.1 Acceptance standards for 4.2.2.2 through 4.2.2.5 shall be mutually agreed upon between the purchaser and vendor.

4.2.2.2 Radiographic Inspections

Radiography shall be based upon the procedures of ASTM Standard Practice E 94.

4.2.2.3 Ultrasonic Inspection

Ultrasonic inspection shall be based upon the procedures ASTM A 609 (castings), ASTM A 388 (forgings), or ASTM A 578 (plate).

4.2.2.4 Magnetic Particle Inspection

Both wet and dry methods of magnetic particle inspection shall be based upon the procedures of ASTM Standard Practice E 709.

4.2.2.5 Liquid Penetrant Inspection

Liquid penetrant inspection shall be based upon the procedures of ASTM Standard Practice E 165.

4.3 TESTING

4.3.1 General

4.3.1.1 Equipment shall be tested in accordance with 4.3.2 through 4.3.7. Other tests that may be specified by the purchaser are described in 4.3.8.

4.3.1.2 At least 6 weeks prior to the first scheduled mechanical running test, the vendor shall submit to the purchaser for his review and comment, detailed procedures for the mechanical

running test and all specified running optional tests (see 4.3.8) including acceptance criteria for all monitored parameters.

4.3.1.3 The vendor shall notify the purchaser not less than 5 working days before the date the equipment will be ready for testing. If the testing is rescheduled, the vendor shall notify the purchaser not less than 5 working days before the new test date.

4.3.2 Hydrostatic Test

4.3.2.1 Pressure-containing parts shall be tested hydrostatically with liquid at a minimum of 1.5 times the maximum allowable working pressure but not less than 140 kPa gauge (20 psig).

4.3.2.2 Tests shall be maintained for a sufficient period of time to permit complete examination of parts under pressure. The hydrostatic test shall be considered satisfactory when neither leaks nor seepage through the casing or casing joint is observed for a minimum of 30 min. Large, heavy castings may require a longer testing period to be agreed upon by the purchaser and the vendor. Seepage past internal closures required for testing of segmented cases and operation of a test pump to maintain pressure are acceptable.

4.3.2.3 The chloride content of liquids used to test austenitic stainless steel materials shall not exceed 50 parts per million. To prevent deposition of chlorides on austenitic stainless steel as a result of evaporative drying, all residual liquid shall be removed from tested parts at the conclusion of the test.

4.3.3 Overspeed Test

4.3.3.1 Impeller Overspeed Test

Each impeller shall be subjected to an overspeed test at not less than 115% of maximum continuous speed for a minimum duration of 1 min. Impeller dimensions identified by the manufacturer as critical (such as bore, eye seal, and outside diameter) shall be measured before and after each overspeed test. All such measurements and the test speeds shall be recorded and submitted for the purchaser's review following the test. Any permanent deformation of the bore or other critical dimension outside drawing tolerances might be cause for rejection.

4.3.3.2 Axial blading requirements are covered in Chapter 2.

4.3.4 To prevent the buildup of potential voltages in the shaft, residual magnetism of the rotating element shall not exceed 0.0005 tesla (5 gauss).

4.3.5 Gas seals shall be testing at seal vendor's shop per requirements of Annex 1D.

4.3.6 Mechanical Running Test

For additional specifics regarding mechanical running tests, see the applicable chapters.

4.3.6.1 During the mechanical running test, the requirements of 4.3.6.1.1 through 4.3.6.1.5 shall be met.

4.3.6.1.1 During the mechanical running test, the mechanical operation of all equipment being tested and the operation of the test instrumentation shall be satisfactory. The equipment measured unfiltered vibration shall not exceed the limits of 2.6.8.8 and shall be recorded throughout the operating speed range.

- **4.3.6.1.2** Synchronous vibration amplitude and phase angle versus speed for deceleration shall be plotted before and after the 4-hour run. Both the synchronous (one per revolution) and overall vibration levels shall be plotted. When specified, these data shall also be furnished in polar form. The speed range covered by these plots shall be from trip speed to 400 rpm.

- **4.3.6.1.3** When specified, tape recordings shall be made of all real-time vibration data as mutually agreed upon by the purchaser and the vendor.

4.3.6.1.4 The following seal flow data shall be taken during the compressor mechanical running test to assure that the seals are installed and operating properly:

- a. For compressors with oil seals, inner oil leakage shall be measured at each seal.
- b. For single dry gas seals, flow in the vent line from each seal shall be measured.
- c. For tandem dry gas seals, flow in the primary and secondary vent line from each seal shall be measured.
- d. For double dry gas seals, the total flow to each seal shall be measured.

Note 1: Seal performance at contract conditions is normally demonstrated in separate tests by the seal manufacturer (see 2.8 for the requirements).

Note 2: Flow in the vents of single or tandem seals may include buffer or separation gas, in addition to seal leakage.

- **4.3.6.1.5** When specified, lube-oil and seal-oil inlet pressures and temperatures shall be varied through the range permitted in the compressor operating manual. This shall be done during the 4-hour test. This option, when specified, does not constitute a waiver of the other specified test requirements.

4.3.6.2 Unless otherwise specified, the requirements of 4.3.6.2.1 through 4.3.6.2.4 shall be met after the mechanical running test is completed.

4.3.6.2.1 All hydrodynamic bearings shall be removed, inspected, and reassembled after the mechanical running test is completed.

- **4.3.6.2.2** When specified, shaft end seals shall be removed for inspection following a successful running test.

Note: Removal and inspection of some seal types (such as cartridges) may require that the seal be returned to the seal manufacturer's facility.

4.3.6.2.3 If replacement or modification of bearings or seals or dismantling of the case to replace or modify other parts is required to correct mechanical or performance deficiencies, the initial test will not be acceptable, and the final shop tests shall be run after these replacements or corrections are made. A mechanical retest is not required when the compressor case must be dismantled to comply with the requirements of 4.3.6.2.2.

4.3.6.2.4 If minor scuffs and scratches occur on bearings or process gas seal surfaces, minor cosmetic repairs of these parts is not a cause for rerunning the test. Shaft end seal contacts that result in a measurable change in dimension or metal transfer may be cause for rejection.

4.3.7 Assembled Machine Gas Leakage Test

For assembled gas leak testing, refer to chapters.

4.3.8 Optional Tests

Additional optional tests are covered in the applicable chapters.

● 4.3.8.1 Performance Test

Performance testing requirements for specific equipment types are covered in the subsequent chapters of this standard.

● 4.3.8.2 Helium Test

The compressor casing shall be tested for gas leakage with helium at the maximum allowable working pressure. The test shall be conducted with the casing submerged in water. The maximum allowable working pressure shall be maintained for a minimum of 30 min., with no bubbles permitted. As an alternative, a nonsubmerged soap-bubble test may be performed if approved by the purchaser.

Note: This test is done immediately after hydrotest.

● 4.3.8.3 Sound-level Test

The sound-level test shall be performed in accordance with purchaser requirements.

● 4.3.8.4 Auxiliary-equipment Test

Auxiliary equipment such as oil systems and control systems shall be tested in the vendor's shop. Details of the auxiliary-equipment tests shall be developed jointly by the purchaser and the vendor.

● 4.3.8.5 Post-test Inspection of Compressor Internals

The compressor shall be dismantled, inspected, and reassembled after satisfactory completion of the mechanical running test. The purchaser will specify whether the gas test shall be performed before or after the post-test inspection.

Note: The merits of post-test inspection of compressor internals should be evaluated against the benefits of shipping a unit with proven mechanical assembly and casing joint integrity.

● 4.3.8.6 Full-pressure/Full-load/Full-speed Test

The details of the full-pressure/full-load/full-speed test shall be developed jointly by the purchaser and the vendor. This test may be substituted for the mechanical running test.

● 4.3.8.7 Post-test Inspection of the Hydraulic Coupling Fit

After the running tests, the shrink fit of hydraulically mounted couplings shall be inspected by comparing hub/shaft match marks to ensure that the coupling hub has not moved on the shaft during the tests.

● 4.3.8.8 Spare-parts Test

Spare parts such as rotors, gears, diaphragms, bearings, and seals shall be tested as specified.

4.4 PREPARATION FOR SHIPMENT

4.4.1 Equipment shall be suitably prepared for the type of shipment specified, including blocking of the rotor when necessary. Blocked rotors shall be identified by means of corrosion-resistant tags attached with stainless steel wire. The preparation shall make the equipment suitable for 6 months of outdoor storage from the time of shipment, with no disassembly required before operation, except for inspection of bearings and seals. If storage for a longer period is contemplated, the purchaser will consult with the vendor regarding the recommended procedures to be followed.

4.4.2 The vendor shall provide the purchaser with the instructions necessary to preserve the integrity of the storage preparation after the equipment arrives at the job site and before start-up.

4.4.3 The equipment shall be prepared for shipment after all testing and inspection have been completed and the equipment has been released by the purchaser. The preparation shall include that specified in 4.4.3.1 through 4.4.3.12 (see Annex B of each chapter).

4.4.3.1 Exterior surfaces, except for stainless steel or machined surfaces, shall be given at least one coat of the manufacturer's standard finish paint. The paint shall not contain lead or chromates.

4.4.3.2 Exterior machined surfaces shall be coated with a suitable rust preventive.

4.4.3.3 The interior of the equipment shall be clean and free from scale, welding spatter, and foreign objects. The selection and application of preservatives or rust preventives shall be mutually agreed upon by the purchaser and the vendor.

4.4.3.4 Internal steel areas of bearing housings and carbon steel oil systems' auxiliary equipment such as reservoirs, vessels, and piping shall be coated with a suitable oil-soluble rust preventive.

4.4.3.5 Flanged openings shall be provided with metal closures at least 5 mm (³/₁₆ in.) thick, with elastomeric gaskets and at least four full-diameter bolts. For studded openings, all nuts needed for the intended service shall be used to secure closures.

4.4.3.6 Threaded openings shall be provided with steel caps or solid-shank steel plugs. In no case shall nonmetallic (such as plastic) plugs or caps be used.

4.4.3.7 Openings that have been beveled for welding shall be provided with closures designed to prevent entrance of foreign materials and damage to the bevel.

4.4.3.8 Lifting points and lifting lugs shall be clearly identified on the equipment or equipment package. The recommended lifting arrangement shall be identified on boxed equipment.

4.4.3.9 The equipment shall be identified with item and serial numbers. Material shipped separately shall be identified with securely affixed, corrosion-resistant metal tags indicating the item and serial number of the equipment for which it is intended. In addition, crated equipment shall be shipped with duplicate packing lists, one inside and one on the outside of the shipping container.

4.4.3.10 When a spare rotor is purchased, the rotor shall be prepared for unheated indoor storage for a period of at least three years. The rotor shall be treated with a rust preventative and shall be housed in a vapor-barrier envelope with a slow release vapor-phase inhibitor. The rotor shall be crated for domestic or export shipment, as specified. Protective sheeting at least 3 mm (¹/₈ in.) thick, or a purchaser-approved equivalent shall be used between the rotor and the cradle at the support areas. The rotor shall not be supported at journals.

● **4.4.3.11** When specified, the fit-up and assembly of machine mounted piping and intercoolers shall be completed in the vendor's shop prior to shipment.

4.4.3.12 Exposed shafts and shaft couplings shall be wrapped with waterproof, moldable waxed cloth or volatile-corrosion-inhibitor paper. The seams shall be sealed with oil-proof adhesive tape.

4.4.4 Auxiliary piping connections furnished on the purchased equipment shall be impression stamped or permanently tagged to agree with the vendor's connection table or general arrangement drawing.

4.4.5 Connections on auxiliary piping removed for shipment shall be match marked clearly for reassembly.

4.4.6 One copy of the manufacturer's standard installation instructions shall be packed and shipped with the equipment.

SECTION 5—VENDOR'S DATA

5.1 GENERAL

5.1.1 The information to be furnished by the vendor is specified in 5.2 and 5.3.

5.1.2 The data shall be identified on transmittal (cover) letters, title pages and in title blocks, or other prominent position on the drawings, with the following information: (5.2.1, 5.3.1.1, 5.3.4.1, and 5.3.5.1):

- a. The purchaser/owner's corporate name.
- b. The job/project number.
- c. The equipment item number and service name.
- d. The inquiry or purchase order number.
- e. Any other identification specified in the inquiry or purchase order.
- f. The vendor's identifying proposal number, serial number, or other reference required to completely identify return correspondence.

5.1.3 A coordination meeting shall be held, preferably at the vendor's plant, within a mutually agreed time after the purchase commitment. Unless otherwise specified, the vendor will prepare and distribute an agenda prior to this meeting, which, as a minimum, shall include review of the following items:

- a. The purchase order, scope of supply, unit responsibility, sub-vendor items, and lines of communication.
- b. The data sheets.
- c. Applicable specifications and previously agreed upon exceptions.
- d. Schedules for transmittal of data, production, and testing.
- e. The quality assurance program and procedures.
- f. Inspection, related acceptance criteria, and testing.
- g. Expediting.
- h. Schematics and bills of material for auxiliary systems.
- i. The general arrangement of equipment, piping, and auxiliary systems. Operating and maintenance access areas shall be reviewed. Access for any parts required for maintenance shall be detailed.
- j. Coupling selections and rating.
- k. Thrust- and journal-bearing sizing, estimated loading and specific configurations.
- l. The rotor dynamics analysis (lateral, torsional, and transient torsional, as required).

m. Machine performance for normal and other specified conditions and other operating conditions, such as start-up, shutdown, and any operating limitations.

n. Instrumentation and controls.

o. Items for design reviews.

p. Other technical items.

q. Seal operation and controls.

- **5.1.4** When specified, a design audit/review meeting shall be held at the vendors plant within 16 weeks after order commitment. The purchaser/owner shall prepare and distribute the agenda prior to the meeting.

5.2 PROPOSALS

5.2.1 General

The vendor shall forward the original proposal with the specified number of copies, to the addressee specified in the inquiry documents. The proposal shall include, as a minimum, the data specified in 5.2.2 through 5.2.4, and a specific statement that the equipment and all its components are in strict accordance with this standard. If the equipment or any of its components or auxiliaries is not in strict accordance, the vendor shall include a list that details and explains each deviation. The vendor shall provide sufficient detail to enable the purchaser to evaluate any proposed alternative designs. All correspondence shall be clearly identified in accordance with 5.1.2.

5.2.2 Drawings

5.2.2.1 The drawings indicated on the Vendor Drawing and Data Requirements (VDDR) form (see Annex B of each chapter) shall be included in the proposal. As a minimum, the following shall be included. A general arrangement or outline drawing for each machine train or skid mounted package, showing overall dimensions, maintenance clearance dimensions, overall weights, installation weights, and maximum maintenance weights for each item.

a. The direction of rotation and the size and location of major purchaser connections shall also be indicated.

b. Cross-sectional drawings, of major equipment, showing the details of the proposed equipment.

c. Schematics of all auxiliary systems, including the fuel, lube oil, seal oil, or self-acting dry gas, control, and electrical systems. Bills of material shall be included.

d. Sketches that show methods of lifting the assembled machine or machines and major components and auxiliaries. (This information may be included on the drawings specified in item a above.)

5.2.2.2 If typical drawings, schematics, and bills of material are used, they shall be marked up to show the expected weight and dimensions to reflect the actual equipment and scope proposed.

5.2.3 Technical Data

The following data shall be included in the proposal:

a. The purchaser's data sheets, with complete vendor's information entered thereon and literature to fully describe details of the offering.

b. The predicted noise data (see 2.1.9).

c. The VDDR form (see Annex B of each chapter), indicating the schedule according to which the vendor agrees to transmit all the data specified.

d. A schedule for shipment of the equipment, in weeks after receipt of an order.

e. A list of major wearing components, showing any interchangeability with the owners existing machines.

f. A list of spare parts recommended for start-up and normal maintenance purposes.

g. A list of the special tools furnished for maintenance.

h. A description of any special weather protection and winterization required for start-up, operation, and periods of idleness, under the site conditions specified on the data sheets. This description shall clearly indicate the protection to be furnished by the purchaser, as well as that included in the vendor's scope of supply.

i. A complete tabulation of utility requirements, e.g., steam, water, electricity, air, gas, lube oil and seal oil (including the quantity and supply pressure of oil required and the heat load to be removed by the oil), and the nameplate power rating and operating power requirements of auxiliary drivers. (Approximate data shall be defined and clearly identified as such.)

j. A description of any optional or additional tests and inspection procedures for materials as required by 2.2.1.4.

k. A description of any special requirements, specified in the purchaser's inquiry.

l. A list of machines, similar to the proposed machine(s) that have been installed and operating under conditions analogous to those specified in the inquiry.

m. Any start-up, shutdown, or operating restrictions required to protect the integrity of the equipment.

n. A list of any components that can be construed as being of alternative design, hence requiring purchaser's acceptance (see 1.2).

o. A summary of the materials of construction, including hardness for materials exposed to H₂S (see 2.2.1.6) and a detailed description of the impeller (type of construction, materials, and method of attachment to the shaft) or blade.

p. The maximum seal-gas rates (injection or eduction) and rated or expected inner seal-oil leakage rates, if applicable. The inner seal-oil leakage shall be given on the basis of volume per day per machine at design gas or oil differential pressures and normal machine speed. When self-acting dry gas seals are supplied, expected seal gas consumption, minimum seal gas supply flow, and primary vent flow should be given at the maximum sealing pressure, and at the conditions over the operating envelope of the machine.

q. When interstage coolers are furnished by the vendor, data for the purchaser's heat and material balances and details of provisions for separating and withdrawing the condensate, including drawings that show cooling system details, and the vendor's recommendations regarding provision for support and piping expansion.

r. Drawings, details, and descriptions of the operations of instrumentation and controls, as well as the makes, materials, and types of auxiliary equipment. The vendor shall also include a complete description of the alarm and shutdown facilities to be provided.

s. The minimum length of straight pipe required for proper flow characteristics at the inlet and at any side inlet connection.

t. A description of the buffer gas system for oil seals or the barrier gas system for dry seals, when applicable.

u. Maximum and minimum allowable seal pressures for each compressor.

v. A statement of the manufacturer's capability regarding testing (including performance testing) of the compressor and any other specified items on the train. Details of each optional test specified shall be included.

5.2.4 Curves

Performance curves shall be submitted for each section (between purchaser's process nozzles) of each casing as well as an overall curve for the train. These curves shall encompass the map of operations, with any limitations indicated thereon. All curves shall be marked "PREDICTED."

5.2.4.1 Curves for variable-speed compressors shall include the following: discharge pressure; power; polytropic head; and polytropic efficiency versus inlet capacity (from predicted surge point to 115% rated capacity) at minimum operating speed and 80%, 90%, 100%, and 105% speed, and indicating the effect of specified inlet pressures, temperatures, and molecular weights. Any specified operating points shall be noted within the envelope of the performance curve predicted.

5.2.4.2 Curves and data for fixed speed compressors shall include the following:

- a. Discharge pressure; power; polytropic head; and polytropic efficiency versus capacity (from surge point to 115% rated capacity) at normal speed, indicating the effect of specified molecular weights, suction pressures, and temperatures. Alternate operating conditions requiring throttling shall be shown.
- b. Speed versus torque to overcome friction and windage for the compressor and gear unit, if any, for normal starting conditions (throttled suction) and also with specified suction conditions for emergency starting (open suction).
- c. Motor torque versus speed at rated voltage and at 80% of rated voltage.
- d. Motor current versus speed at rated voltage and at 80% of rated voltage.
- e. WK2 of the compressor, the gear, the motor, and the coupling(s) referred to motor speed.
- f. Estimated times for acceleration to rated speed for throttled suction and for open suction at 80% of the nameplate motor voltage unless otherwise specified.

5.2.5 Options

The vendor shall furnish an outline of the procedures to be used for each of the special or optional tests that have been specified by the purchaser or proposed by the vendor.

5.3 CONTRACT DATA

5.3.1 General

5.3.1.1 Contract data shall be furnished by the vendor in accordance with the agreed VDDR form (Annex B of each chapter).

5.3.1.2 Each drawing shall have a title block in its lower right-hand corner with the date of certification, identification data as specified in 5.1.2, the revision number and date, and the title. Similar information shall be provided on all other documents including sub vendor items.

5.3.1.3 The purchaser will promptly review the vendor's data upon receipt; however, this review shall not constitute permission to deviate from any requirements in the order unless specifically agreed upon in writing. After the data has been reviewed and accepted, the vendor shall furnish certified copies in the quantities specified.

5.3.1.4 A complete list of vendor data shall be included with the first issue of the major drawings. This list shall contain titles, drawing numbers, and a schedule for transmittal of each item listed. The list shall cross reference data with respect to the VDDR form in Annex B of the applicable chapter.

5.3.2 Drawings and Technical Data

The drawings and data furnished by the vendor shall contain sufficient information so that together with the manuals specified in 5.3.5, the purchaser can properly install, operate, and maintain the equipment covered by the purchase order. All contract drawings and data shall be clearly legible (8 point minimum font size, even if reduced from a larger size drawing), shall cover the scope of the agreed VDDR form, and shall satisfy the applicable detailed descriptions in Annex D of the applicable chapter.

5.3.2.1 Curves

5.3.2.1.1 The vendor shall provide complete performance curves to encompass the map of operations, with any limitations indicated. The curves shall comply with the requirements of 5.3.2.1.2 through 5.3.2.1.6.

5.3.2.1.2 All curves submitted prior to final performance testing (if required) shall be marked "PREDICTED." Any set of curves resulting from a test shall be marked "TESTED."

5.3.2.1.3 If a performance test is specified, the vendor shall provide test data and curves when the test has been completed. The surge points shall be shown on the performance curves.

5.3.2.1.4 For compressors that have a back-to-back impeller arrangement, the vendor shall furnish a curve showing the expected loading on the active or inactive side of the thrust bearing versus any combination of the differential pressures across the low-pressure and high-pressure sections of the casing.

- **5.3.2.1.5** When specified, the vendor shall supply curves of balance piston line differential pressure versus thrust load.

5.3.2.1.6 The vendor shall supply balance piston leakage based on design clearances and twice design clearances for the rated condition.

5.3.2.2 Data Sheets

The vendor shall provide full information to enable completion of the data sheets for the train and auxiliary equipment, first for "as-purchased," and then for "as-built." This should be done by the vendor correcting and filling out the data sheets and submitting copies to the purchaser. Datasheets are available in Annex A of each chapter.

5.3.3 Progress Reports

5.3.3.1 The vendor shall submit progress reports to the purchaser at the intervals specified on the VDDR form (see Annex B of each chapter). Planned and actual dates and the percentage completed shall be indicated for each milestone in the schedule.

- **5.3.3.2** When specified, one week prior to the start of assembly the vendor shall issue a "Tail End Schedule," bi-weekly. The schedule shall include major assemblies, sub-assemblies, test setup, testing, paint, pack and shipment preparation. Included in the columns shall be Start (Schedule/Actual), Finish (Schedule/Actual), Status (Sym./Date), Comments.

5.3.4 Recommended Spare Parts

5.3.4.1 The vendor shall submit complete parts lists for all equipment and accessories supplied. These lists shall include part names, manufacturers unique part numbers, materials of construction (identified by applicable international standards). Each part shall be completely identified and shown on appropriate cross-sectional, assembly-type cutaway or exploded-view isometric drawings. Interchangeable parts shall be identified as such. Parts that have been modified from standard dimensions or finish to satisfy specific performance requirements shall be uniquely identified by part number. Standard purchased items shall be identified by the original manufacturer's name and part number.

5.3.4.2 The vendor shall indicate on each of these complete parts lists all those parts that are recommended as start-up or maintenance spares, and the recommended stocking quantities of each. These should include spare parts recommendations of subsuppliers that were not available for inclusion in the vendor's original proposal.

5.3.5 Installation, Operation, Maintenance, and Technical Data Manuals

5.3.5.1 General

5.3.5.1.1 The vendor shall provide sufficient written instructions and all necessary drawings to enable the purchaser to install all of the equipment covered by the purchase order. This information shall be compiled in a manual or manuals with a cover sheet showing the information listed in 5.1.2, a Table of Contents, and an index sheet for each sec-

tion, a complete list of the enclosed drawings by title, drawing number and revision. The manual pages and drawings shall be numbered. The manual or manuals shall be prepared specifically for the equipment covered in the purchase order. "Typical" manuals are unacceptable.

- **5.3.5.1.2** When specified, a draft manual(s) shall be issued to purchaser 8 weeks prior to testing for review and comment.

5.3.5.2 Installation Manual

All information required for the proper installation of the equipment shall be compiled in a manual that must be issued no later than the time of final certified drawings. For this reason, it may be separate from the operation and maintenance instructions. This manual shall contain information on alignment and grouting procedures, (normal and maximum utility requirements), centers of mass, rigging procedures and other installation data. All drawings and data specified in 5.2.2 and 5.2.3 that are pertinent to proper installation shall be included as part of this manual.

One extra manual, over and above the specified quantity, shall be included with the first equipment shipment.

5.3.5.3 Operating and Maintenance Manual

A manual containing all required operating and maintenance instructions shall be supplied not later than 2 weeks after all specified tests have been successfully completed.

- **5.3.5.4 Technical Data Manual**

When specified, the vendor shall provide the purchaser with a technical data manual within 30 days of completion of shop testing. See description in Annex B of each of the listed chapters for minimum requirements of this manual:

- Chapter 2, line 53
- Chapter 3, line 57
- Chapter 4, line 54

.....

**ANNEX 1A
REFERENCE LIST OF U.S., ISO, AND
INTERNATIONAL STANDARDS
(NORMATIVE)**

ORGANIZATION	STANDARD	DESCRIPTION OR ADDRESS
API		American Petroleum Institute 1220 L Street, Northwest Washington, D.C. 20005 (202) 682-8000 http://www.api.org
	API Std 541	<i>Form-wound Squirrel-cage Induction Motors—250 Horsepower and Larger—3rd edition, April 1995</i>
	API Std 546	<i>Brushless Synchronous Machines—500 kVA and Larger—2nd edition, June 1997</i>
	API Std 612	<i>Special Purpose Steam Turbines for Petroleum, Chemical, and Gas Industry Services—4th edition, June 1995</i>
	API Std 613	<i>Special Purpose Gear Units for Petroleum, Chemical, and Gas Industry Services—4th edition, June 1995</i>
	API Std 614	<i>Lubrication, Shaft-sealing, and Control-oil Systems and Auxiliaries for Petroleum, Chemical and Gas Industry Services—4th edition, April 1999</i>
	API Std 616	<i>Gas Turbines for the Petroleum, Chemical and Gas Industry Services—4th edition, August 1998</i>
	API Std 670	<i>Vibration, Axial Position, and Bearing Monitoring Systems—3rd edition, November 1993</i>
	API Std 671	<i>Special Purpose Couplings for Refinery Service—2nd edition, February 1990</i>
	API Std 672	<i>Packaged, Integrally Geared Centrifugal Air Compressors for Petroleum, Chemical, and Gas Industry Services—3rd edition, September 1996</i>
	API Std 673	<i>Special Purpose Centrifugal Fans for General Refinery Service—1st edition, 1982</i>
	API RP 683	<i>Quality Improvement Manual for Mechanical Equipment in Petroleum, Chemical and Gas Industries—1st edition, September 1993</i>
	API Publ 684	<i>Tutorial on the API Standard Paragraphs Covering Rotor Dynamics and Balancing: An Introduction to Lateral Critical and Train Torsional Analysis and Rotor Balancing—1st edition, February 1996</i>
	API RP 686	<i>Machinery Installation and Installation Design—1st edition, February 1996</i>
ASTM		American Society for Testing and Materials ASTM 100 Bar Harbor Drive West Conshohocken, Pennsylvania 19428-2959 (610) 832-9585 http://www.astm.org/
	A 193	<i>Standard Specification for High Alloy Steel for High-temperature Service</i>
	A 194	<i>Standard Specification for Carbon and Alloy Steel Nuts for Bolts for High-pressure or High-temperature Service</i>
	A 305	
	A 388	<i>Standard Practice for Ultrasonic Examination of Heavy Steel Forgings—1995</i>
	A 395	<i>Standard Specification for Ferritic Ductile Iron Pressure-Retaining Castings for Use at Elevated Temperatures—1999</i>
	A 515	<i>Standard Specification for Pressure Vessel Plates, Carbon Steel, for Intermediate- and Higher-temperature Service—1992 (1997)</i>
	A 563/A 563M	<i>Standard Specification for Carbon and Alloy Steel Nuts—1997</i> Note: A563M is Metric.
	A 578	<i>Standard Specification for Straight-beam Ultrasonic examination of Plain and Clad Steel Plates for Special Applications—1996</i>
	A 609	<i>Standard Practice for Castings, Carbon, Low-alloy, and Martensitic Stainless Steel, Ultrasonic Examination Thereof—1997</i>
	E 94	<i>Standard Guide for Radiographic Testing—1993</i>
	E 125	<i>Standard Reference Photographs for Magnetic Particle Indications on Ferrous Castings—1963 (1997)</i>

ORGANIZATION	STANDARD	DESCRIPTION OR ADDRESS
	E 165	<i>Standard Test Method for Liquid Penetrant Examination—1995</i>
	E 709	<i>Standard Guide for Magnetic Particle Examination—1995</i>
AWS		American Welding Society 550 NW LeJeune Road Miami, Florida 33126 (800) 443-9353 http://www.aws.org/
	D 1.1	
AISI		American Iron and Steel Institute 1101 17th Street Northwest Suite 1300 Washington, D.C. 20036 (202) 452-7100 http://www.steel.org/
	Type 300 Stainless Steel	
ASME/ANSI		The American Society of Mechanical Engineers ASME International Three Park Avenue New York, New York 10016-5990 (800) THE-ASME http://www.asme.org/ Note: ANSI (American National Standards Institute) is the national standards body for the U.S. They do not actually generate specifications. Refer to ASME for copies of specifications.
	B1.1	<i>Unified Inch Screw Threads, UN and UNR Thread Form—Published 1989</i>
	B1.20.1	<i>Pipe Threads, General Purpose, Inch—Published 1983—Reaffirmed 1992</i>
	B16.11	<i>Forged Fittings Socket Welding and Threaded—Published 1996</i>
	B16.42	<i>Ductile Iron Pipe Flanges and Flanged Fittings: Classes 150 and 300—Published 1998</i>
	B16.47	<i>Large Diameter Steel Flanges—Published 1996</i>
	B16.1	<i>Cast Iron Pipe Flanges and Flanged Fittings—Published 1998</i>
	B16.5	<i>Pipe Flanges and Flanged Fittings—Published 1996</i>
	B19.3	<i>Safety Standard for Compressors for Process Industry—Published 1991</i>
	ASME Pressure Vessel Code	<i>Boiler and Pressure Vessel Code—Published 2000</i>
	Section IX	
SAE		Society of Automotive Engineers SAE World Headquarters 400 Commonwealth Drive Warrendale, Pennsylvania 15096-0001 http://www.sae.org/

ORGANIZATION	STANDARD	DESCRIPTION OR ADDRESS
NACE		National Association of Corrosion Engineers NACE International 1440 South Creek Drive Houston, Texas 77084 (281) 228-6200 http://www.nace.org/
	MR0175-2000 Update Spec Reference	<i>Sulfide Stress Cracking Resistant Metallic Materials for Oilfield Equipment</i>
NFPA		National Fire Protection Association 1 Battermarch Park Quincy, MA 02269-9101
	Document No. 30	<i>Flammable and Combustible Liquids Code</i> , 1996 French Edition
	70, Articles 500 – 505	<i>National Electrical Code</i>
ISO		International Organization for Standardization (ISO) ISO Central Secretariat 1, rue de Varembe Case postale 56 CH-1211 Geneve 20 Switzerland +41 22 749 01 11 http://www.iso.ch/
	7-1:1994	<i>Pipe Threads Where Pressure-tight Joints are Made on the Threads—Part 1: Dimensions, Tolerances and Designations</i>
	7-2:1982	<i>Pipe Threads Where Pressure-tight Joints are Made on the Threads—Part 2: Verification by Means of Limit Gauges</i>
	261:1998	<i>ISO General-purpose Metric Screw Threads—General Plan</i>
	262:1998	<i>ISO General-purpose Metric Screw Threads—Selected Sizes for Screws, Bolts and Nuts</i>
	724:1993	<i>ISO General-purpose Metric Screw Threads—Basic Dimensions</i>
	965	<i>ISO General purpose Metric Screw Threads—Tolerances</i>
	10437:1993	<i>Petroleum and Natural Gas Industries—Special-purpose Steam Turbines for Refinery Service</i>
	1940-1:1986	<i>Mechanical Vibration—Balance Quality Requirements of Rigid Rotors—Part 1: Determination of Permissible Residual Unbalance</i>
	1940-2:1997	<i>Mechanical Vibration—Balance Quality Requirements of Rigid Rotors—Part 2: Balance Errors</i>
	7005-1:1992	<i>Metallic Flanges—Part 1: Steel Flanges</i>
	8501-1:1988	<i>Preparation of Steel Substrates before Application of Paints and Related Products—Visual Assessment of Surface Cleanliness—Part 1: Rust Grades and Preparation Grades of Uncoated Steel Substrates and of Steel Substrates after Overall Removal of Previous Coatings</i>
	8501-1:1988/Suppl:1994	<i>Representative Photographic Examples of the Change of Appearance Imparted to Steel when Blast-cleaned with Different Abrasives</i>
	8501-2:1994	<i>Preparation of Steel Substrates before Application of Paints and Related Products—Visual Assessment of Surface Cleanliness—Part 2: Preparation Grades of Previously Coated Steel Substrates after Localized Removal of Previous Coatings</i>
	8821:1989	<i>Mechanical Vibration—Balancing—Shaft and Fitment Key Convention</i>

**ANNEX 1B
PROCEDURE FOR THE DETERMINATION
OF RESIDUAL UNBALANCE
(NORMATIVE)**

B.1 General

This annex describes the procedure to be used to determine residual unbalance in machine rotors. Although some balancing machines may be set up to read out the exact amount of unbalance, the calibration can be in error. The only sure method of determining is to test the rotor with a known amount of unbalance.

B.2 Residual Unbalance

Residual unbalance is the amount of unbalance remaining in a rotor after balancing. Unless otherwise specified, residual unbalance shall be expressed in g-mm (g-in.).

B.3 Maximum Allowable Residual Unbalance

B.3.1 The maximum allowable residual unbalance, per plane, shall be calculated according to the paragraph from the standard to which this annex is attached.

B.3.2 The static weight on each journal shall be determined by physical measurement (calculation methods may introduce errors). It should NOT simply be assumed that rotor weight is equally divided between the two journals. There can be great discrepancies in the journal weight to the point of being very low (even negative on over-hung rotors). In the example problem, the left plane has a journal weight of 530.7 kg (1170 lb.). The right plane has a journal weight of 571.5 kg (1260 lb.).

B.4 Residual Unbalance Check

B.4.1 General

B.4.1.1 When the balancing machine readings indicate that the rotor has been balanced within the specified tolerance, a residual unbalance check shall be performed before the rotor is removed from the balancing machine.

B.4.1.2 To check the residual unbalance, a known trial weight is attached to the rotor sequentially in six equally spaced radial positions (60 degrees apart), each at the same radius (i.e., same moment [g-in.]). The check is run at each balance machine readout plane, and the readings in each plane are tabulated and plotted on the polar graph using the procedure specified in B.4.2.

B.4.2 Procedure

B.4.2.1 Select a trial weight and radius that will be equivalent to between 1 and 2 times the maximum allowable residual unbalance (e.g., if U_{\max} is 488.4 g-mm [19.2 g-in.], the trial

weight should cause 488.4 – 976.8 g-mm [19.2 – 38.4 g-in.] of unbalance). This trial weight and radius must be sufficient so that the resulting plot in B.4.2.5 encompasses the origin of the polar plot.

B.4.2.2 Starting at a convenient reference plane (i.e., ~ last heavy spot), mark off the specified six radial positions (60 degree increments) around the rotor. Add the trial weight near the last known heavy spot for that plane. Verify that the balance machine is responding and is within the range and graph selected for taking the residual unbalance check.

B.4.2.3 Verify that the balancing machine is responding reasonably (i.e., no faulty sensors or displays). For example, if the trial weight is added to the last known heavy spot, the first meter reading should be at least twice as much as the last reading taken before the trial weight was added. Little or no meter reading generally indicates that the rotor was not balanced to the correct tolerance, the balancing machine was not sensitive enough, or that a balancing machine fault exists (i.e., a faulty pickup). Proceed if this check is OK.

B.4.2.4 Remove the trial weight and rotate the trial weight to the next trial position (that is, 60, 120, 180, 240, 300 and 360 degrees from the initial trial weight position). Repeat the initial position as a check for repeatability on the Residual Unbalance Worksheet. All verification shall be performed using only one sensitivity range on the balance machine.

B.4.2.5 Plot the balancing machine amplitude readout versus angular location of trial weight (NOT balancing machine phase angle) on the Residual Unbalance Worksheet and calculate the amount of residual unbalance (refer to worksheets, Figures 1.B-3 and 1.B-5).

Note: The maximum reading occurs when the trial weight is placed at the rotor's remaining heavy spot; the minimum reading occurs when the trial weight is placed opposite the rotor's heavy spot (light spot). The plotted readings should form an approximate circle around the origin of the polar chart. The balance machine angular location readout should approximate the location of the trial weight. The maximum deviation (highest reading) is the heavy spot (represents the plane of the residual unbalance). Blank worksheets are Figures 1.B-1 and 1.B-2.

B.4.2.6 Repeat the steps described in B.4.2.1 through B.4.2.5 for each balance machine readout plane. If the specified maximum allowable residual unbalance has been exceeded in any balance machine readout plane, the rotor shall be balanced more precisely and checked again. If a balance correction is made in any balance machine readout plane, then the residual unbalance check shall be repeated in all balance machine readout planes.

B.4.2.7 For stack component balanced rotors, a residual unbalance check shall be performed after the addition and balancing of the rotor after the addition of the first rotor component, and at the completion of balancing of the entire rotor, as a minimum.

Notes:

1. This ensures that time is not wasted and rotor components are not subjected to unnecessary material removal in attempting to balance a multiple component rotor with a faulty balancing machine.
2. For large multi-stage rotors, the journal reactions may be considerably different from the case of a partially stacked to a completely stacked rotor.

Customer: _____
 Job/Project Number: _____
 OEM Equipment S/N: _____
 Rotor Identification Number: _____
 Repair Purchase Order Number: _____
 Vendor Job Number: _____
 Correction Plane (Left or Right)—use sketch _____ (plane)

Balancing Speed _____ (rpm)
 Maximum Rotor Operating Speed (N) _____ (rpm)
 Static Journal Weight Closest to This Correction Plane (W) _____ (kg) _____ (lb.)
 Trial Weight Radius (R)—the radius at which the trial weight will be placed _____ (mm) _____ (in.)

Calculate Maximum Allowable Residual Unbalance (U_{max}):
 SI Units:
 $U_{max} = \frac{(6350) \times (W)}{(N)} = \frac{(6350)}{\quad} \times \frac{\quad}{\quad} = \quad$ (g-mm)

Customary Units:
 $U_{max} = \frac{(113.4) \times (W)}{(N)} = \frac{(113.4)}{\quad} \times \frac{\quad}{\quad} = \quad$ (g-in.)

Calculate the trial unbalance (TU):
 Trial Unbalance (TU) is between $(1 \times U_{max})$ and $(2 \times U_{max})$
 SI Units: _____ to _____ = _____ (g-mm)
 Customary units: _____ to _____ = _____ (g-in.)

Calculate the trial weight (TW):
 $Trial\ Weight\ (TW) = \frac{U_{max}}{R} = \frac{\quad}{\quad} \text{ g-mm} \quad \text{or} \quad \frac{\quad}{\quad} \text{ g-in.} = \quad$ (g)

Conversion Information:
 1 kg = 2.2046 lb. 1 oz. = 28.345 g

Obtain the test data and complete the table:

Sketch the rotor configuration:

Test Data			
Position	Trial Weight Angular Location on Rotor (degrees)	Balancing Mach Readout	
		Amplitude (grams)	Phase Angle (degrees)
1	0		
2	60		
3	120		
4	180		
5	240		
6	300		
Repeat 1	0		

Rotor Sketch

PROCEDURE:

- Step 1: Plot the balancing machine amplitude versus trial weight angular location on the polar chart (Figure 1.B-2) such that the largest and smallest values will fit.
- Step 2: The points located on the polar chart should closely approximate a circle. If it does not, then it is probably that the recorded data it is in error and the test should be repeated.
- Step 3: Determine the maximum and minimum balancing machine amplitude readings.
- Step 4: Using the worksheet, (Figure 1.B-2), determine the Y and Z values required for the residual unbalance calculation.
- Step 5: Using the worksheet, (Figure 1.B-2), calculate the residual unbalance remaining in the rotor.
- Step 6: Verify that the determined residual unbalance is equal to or less than the maximum allowable residual unbalance (U_{max}).

Half Keys Used for Rotor Balancing
 (add sketch for clarification if necessary)

Location	Weight

NOTES:

- 1) The trial weight angular location should be referenced to a keyway or some other permanent marking on the rotor. The preferred location is the location of the once-per-revolution mark (for the phase reference transducer).
- 2) The balancing machine amplitude readout for the Repeat of 1 should be the same as Position 1, indicating repeatability.
- 3) A primary source for error is not maintaining the same radius for each trial weight location.

Balanced By: _____ Date: _____
 Approved By: _____ Date: _____

Figure 1.B-1—(Blank) Residual Unbalance Worksheet

Customer: _____
 Job/Project Number: _____
 OEM Equipment S/N: _____
 Rotor Identification Number: _____
 Repair Purchase Order Number: _____
 Vendor Job Number: _____
 Correction Plane (Left or Right)—use sketch _____

RESIDUAL UNBALANCE POLAR PLOT

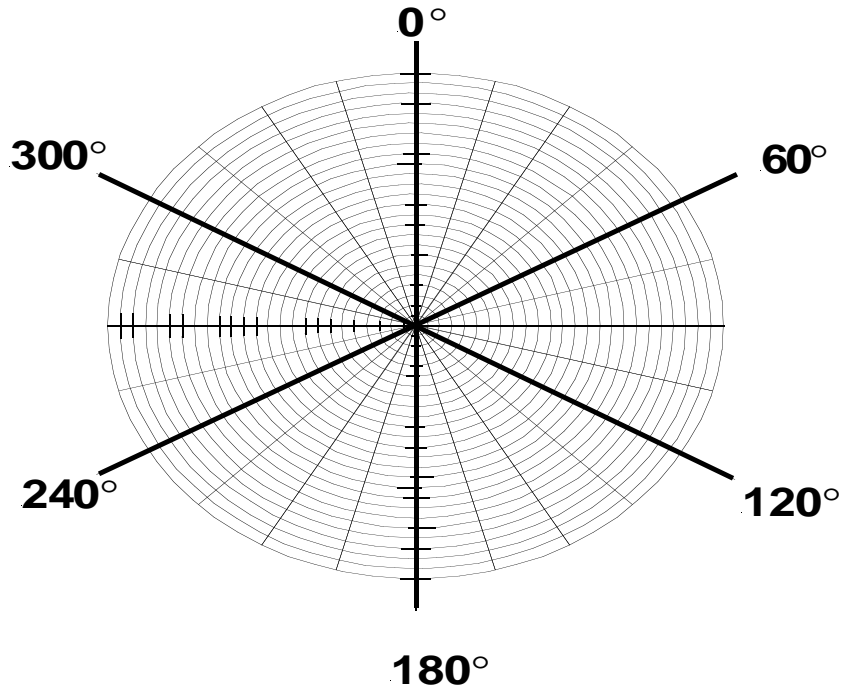

Rotor Rotation: CCW CW Phase is layed out: CCW CW

Calculate Y and Z values:
 Maximum amplitude value is: _____ g Minimum amplitude value is: _____ g
 $Y = (\text{Maximum} - \text{Minimum}) / 2$ $Z = (\text{Maximum} + \text{Minimum}) / 2$

Residual Unbalance
 Left in Rotor = $(TU) \times (Y) / (Z)$
 SI Units: _____
 Customary Units: _____

Allowable Unbalance Tolerance = $U_{max} =$ _____ gm-mm _____ gm-in.

RESULT: Residual unbalance left in the rotor is equal to or less than the allowable unbalance tolerance?
 As Received Final PASS FAIL Other: _____

Balanced By: _____ Date: _____
 Approved By: _____ Date: _____

Figure 1.B-2—(Blank) Residual Unbalance Polar Plot Worksheet

Customer:
 Job/Project Number:
 OEM Equipment S/N:
 Rotor Identification Number:
 Repair Purchase Order Number:
 Vendor Job Number:
 Correction Plane (Left or Right)—use sketch

ABC Refining Co.
 00 – 1234
 C – 1234
 1234 – C – 4320
 PO 12345678
 Shop – 00 – 1234
 Left (plane)

Balancing Speed
 Maximum Rotor Operating Speed (*N*)
 Static Journal Weight Closest to This Correction Plane (*W*)
 Trial Weight Radius (*R*)—the radius at which the trial weight will be placed

800 (rpm)
 6900 (rpm)
 530.7 (kg) 1170 (lb.)
 381 (mm) 15 (in.)

Calculate Maximum Allowable Residual Unbalance (U_{max}):

SI Units:
 $U_{max} = \frac{(6350) \times (W)}{(N)} = \frac{(6350)}{6900} \times 530.7 = 488.4 \text{ (g-mm)}$

Customary Units:
 $U_{max} = \frac{(113.4) \times (W)}{(N)} = \frac{(113.4)}{6900} \times 1170 = 19.2 \text{ (g-in.)}$

Calculate the trial unbalance (*TU*):

Trial Unbalance (*TU*) is between $(1 \times U_{max})$ and $(2 \times U_{max})$
 SI Units 488.4 to 976.8 is 781.4 (g-mm)
 Customary units: 19.2 to 38.5 is 30.8 (g-in.) (Selected Multiplier is 1.6)

Calculate the trial weight (*TW*):

Trial Weight (*TW*) = $\frac{U_{max}}{R} = \frac{781 \text{ g-mm}}{381 \text{ mm}}$ or $\frac{31 \text{ g-in.}}{15 \text{ in.}} = 2.1 \text{ (g)}$

Conversion Information:

1 kg = 2.2046 lb. 1 oz. = 28.345 g

Obtain the test data and complete the table:

Sketch the rotor configuration:

Test Data			
Position	Trial Weight Angular Location on Rotor (degrees)	Balancing Mach Readout	
		Amplitude (grams)	Phase Angle (degrees)
1	0	1.60	358
2	60	1.11	59
3	120	1.58	123
4	180	2.21	182
5	240	3.00	241
6	300	2.30	301
Repeat 1	0	1.58	359

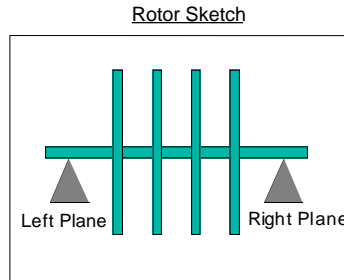

PROCEDURE:

- Step 1: Plot the balancing machine amplitude versus trial weight angular location on the polar chart (Figure 1.B-4) such that the largest and smallest values will fit.
- Step 2: The points located on the polar chart should closely approximate a circle. If it does not, then it is probably that the recorded data it is in error and the test should be repeated.
- Step 3: Determine the maximum and minimum balancing machine amplitude readings.
- Step 4: Using the worksheet, (Figure 1.B-4), determine the Y and Z values required for the residual unbalance calculation.
- Step 5: Using the worksheet, (Figure 1.B-4), calculate the residual unbalance remaining in the rotor.
- Step 6: Verify that the determined residual unbalance is equal to or less than the maximum allowable residual unbalance (U_{max}).

Half Keys Used for Rotor Balancing
 (add sketch for clarification if necessary)

Location	Weight

NOTES:

- 1) The trial weight angular location should be referenced to a keyway or some other permanent marking on the rotor. The preferred location is the location of the once-per-revolution mark (for the phase reference transducer).
- 2) The balancing machine amplitude readout for the Repeat of 1 should be the same as Position 1, indicating repeatability.
- 3) A primary source for error is not maintaining the same radius for each trial weight location.

Balanced By: CJ, TR, & RC Date: 05/24/00
 Approved By: CC Date: 05/24/00

Figure 1.B-3—Sample Residual Unbalance Worksheet for Left Plane

Customer:
 Job/Project Number:
 OEM Equipment S/N:
 Rotor Identification Number:
 Repair Purchase Order Number:
 Vendor Job Number:
 Correction Plane (Left or Right)—use sketch

ABC Refining Co.
 00 - 1234
 C - 1234
 1234 - C - 4320
 PO 12345678
 Shop - 00 - 1234
 Left (plane)

RESIDUAL UNBALANCE POLAR PLOT

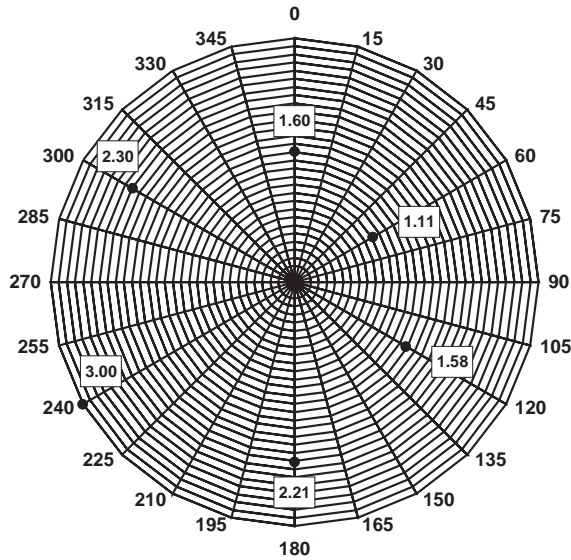

Rotor Rotation: CCW Phase is layed out: CCW
 CW CW

Calculate Y and Z values:
 Maximum amplitude value is:

3.00

 g Minimum amplitude value is:

1.11

 g
 $Y = (\text{Maximum} - \text{Minimum}) / 2 = (3.00 - 1.11) / 2 = 0.9$
 $Z = (\text{Maximum} + \text{Minimum}) / 2 = (3.00 + 1.11) / 2 = 2.1$

Residual Unbalance
 Left in Rotor = $\frac{(TU)}{SI \text{ Units}} \times \frac{(Y)}{Customary \text{ Units}} / \frac{(Z)}{SI \text{ Units}}$
 SI Units:

781

 ×

0.95

 /

2.06

 =

359

 g-mm
 Customary Units:

31

 ×

0.95

 /

2.06

 =

14.1

 g-in.

Allowable Unbalance Tolerance = $U_{max} =$

488.4

 g-mm

19.2

 g-in.

RESULT: Residual unbalance left in the rotor is equal to or less than the allowable unbalance tolerance?

As Received Final Other: w/o trim hardware

PASS

Balanced By: CJ, TR & RC Date: 05/24/00
 Approved By: CC Date: 05/24/00

Figure 1.B-4—Sample Residual Unbalance Polar Plot Worksheet for Left Plane

Customer:
 Job/Project Number:
 OEM Equipment S/N:
 Rotor Identification Number:
 Repair Purchase Order Number:
 Vendor Job Number:
 Correction Plane (Left or Right)—use sketch

ABC Refining Co.
 00 – 1234
 C – 1234
 1234 – C – 4320
 PO 12345678
 Shop – 00 – 1234
 Right (plane)

Balancing Speed
 Maximum Rotor Operating Speed (*N*)
 Static Journal Weight Closest to This Correction Plane (*W*)
 Trial Weight Radius (*R*)—the radius at which the trial weight will be placed

800	(rpm)		
6900	(rpm)		
571.5	(kg)	1260	(lb.)
203	(mm)	8	(in.)

Calculate Maximum Allowable Residual Unbalance (U_{max}):

SI Units:
 $U_{max} = \frac{(6350) \times (W)}{(N)} = \frac{(6350) \times 571.5}{6900} = 525.9$ (g-mm)

Customary Units:
 $U_{max} = \frac{(113.4) \times (W)}{(N)} = \frac{(113.4) \times 1260}{6900} = 20.7$ (g-in.)

Calculate the trial unbalance (*TU*):
 Trial Unbalance (*TU*) is between ($1 \times U_{max}$) and ($2 \times U_{max}$)

SI Units: 525.9 to 1051.9 is 841.5 (g-mm)
 Customary units: 20.7 to 41.4 is 33.1 (g-in.)
 (Selected Multiplier is) 1.6

Calculate the trial weight (*TW*):

Trial Weight (*TW*) = $\frac{U_{max}}{R} = \frac{842}{203}$ g-mm or $\frac{33}{8}$ g-in. = 4.1 (g)

Conversion Information:
 1 kg = 2.2046 lb. 1 oz. = 28.345 g

Obtain the test data and complete the table:

Sketch the rotor configuration:

Position	Test Data		Balancing Mach Readout	
	Trial Weight	Angular Location on Rotor (degrees)	Amplitude (grams)	Phase Angle (degrees)
1	0		4.60	3
2	60		4.20	58
3	120		4.70	121
4	180		5.20	180
5	240		5.80	235
6	300		5.10	301
Repeat 1	0		4.60	2

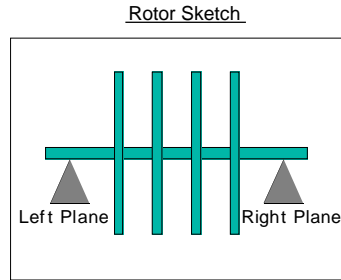

PROCEDURE:

- Step 1: Plot the balancing machine amplitude versus trial weight angular location on the polar chart, (Figure 1.B-6) such that the largest and smallest values will fit.
- Step 2: The points located on the polar chart should closely approximate a circle. If it does not, then it is probably that the recorded data it is in error and the test should be repeated.
- Step 3: Determine the maximum and minimum balancing machine amplitude readings.
- Step 4: Using the worksheet, (Figure 1.B-6), determine the Y and Z values required for the residual unbalance calculation.
- Step 5: Using the worksheet, (Figure 1.B-6), calculate the residual unbalance remaining in the rotor.
- Step 6: Verify that the determined residual unbalance is equal to or less than the maximum allowable residual unbalance (U_{max}).

Half Keys Used for Rotor Balancing
 (add sketch for clarification if necessary)

Location	Weight

NOTES:

- 1) The trial weight angular location should be referenced to a keyway or some other permanent marking on the rotor. The preferred location is the location of the once-per-revolution mark (for the phase reference transducer).
- 2) The balancing machine amplitude readout for the Repeat of 1 should be the same as Position 1, indicating repeatability.
- 3) A primary source for error is not maintaining the same radius for each trial weight location.

Balanced By: CJ, TR, & RC Date: 05/24/00
 Approved By: CC Date: 05/24/00

Figure 1.B-5— Sample Residual Unbalance Worksheet for Right Plane

Customer:
 Job/Project Number:
 OEM Equipment S/N:
 Rotor Identification Number:
 Repair Purchase Order Number:
 Vendor Job Number:
 Correction Plane (Left or Right)—use sketch

ABC Refining Co.
00 – 1234
C – 1234
1234 – C – 4320
PO 12345678
Shop – 00 – 1234
Right (plane)

RESIDUAL UNBALANCE POLAR PLOT

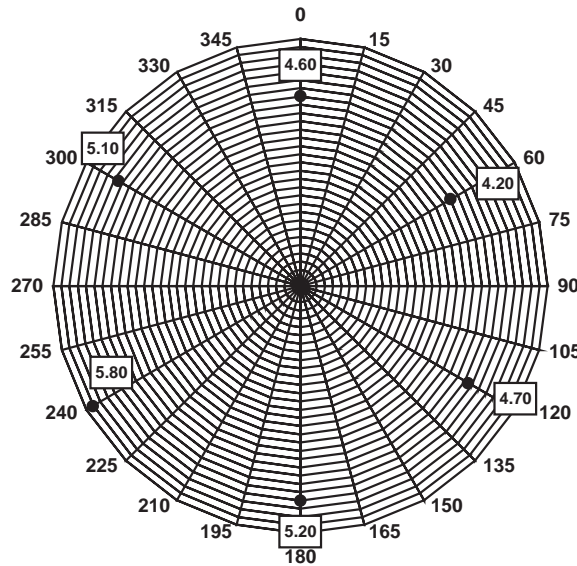

Rotor Rotation: CCW Phase is layed out: CCW
 CW CW

Calculate Y and Z values:
 Maximum amplitude value is:

5.80

 Minimum amplitude value is:

4.20

 g
 $Y = (\text{Maximum} - \text{Minimum}) / 2 = (5.80 - 4.20) / 2 = 0.8$
 $Z = (\text{Maximum} + \text{Minimum}) / 2 = (5.80 + 4.20) / 2 = 5.0$

Residual Unbalance
 Left in Rotor = $\frac{(TU)}{SI \text{ Units}} \times \frac{(Y)}{SI \text{ Units}} / \frac{(Z)}{SI \text{ Units}} = \frac{842}{33} \times \frac{0.8}{0.8} / \frac{5}{5} = \frac{134.6}{5.3}$ g-mm
 Customary Units: $\frac{842}{33} \times \frac{0.8}{0.8} / \frac{5}{5} = \frac{134.6}{5.3}$ g-in.

Allowable Unbalance Tolerance = $U_{max} = \frac{525.9}{20.7}$ g-mm g-in.

RESULT: Residual unbalance left in the rotor is equal to or less than the allowable unbalance tolerance?

As Received Final Other: w/o trim hardware PASS

Balanced By: CJ, TR & RC Date: 05/24/00
 Approved By: CC Date: 05/24/00

Figure 1.B-6— Sample Residual Unbalance Polar Plot Worksheet for Right Plane

.....

**ANNEX 1C
TYPICAL SHAFT END SEAL
CROSS-SECTIONAL DRAWINGS
(INFORMATIVE)**

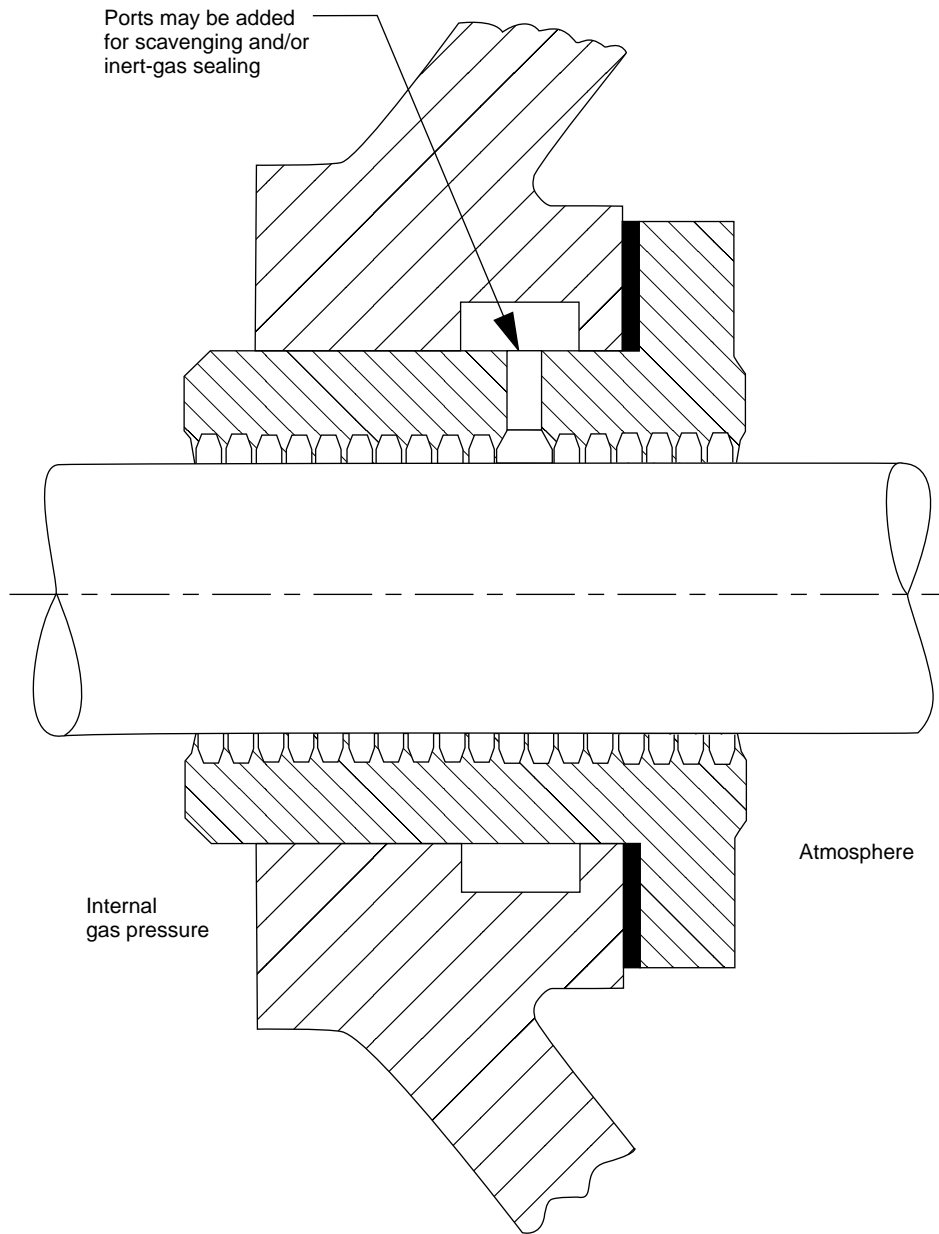

Figure 1.C-1—Labyrinth Shaft Seal

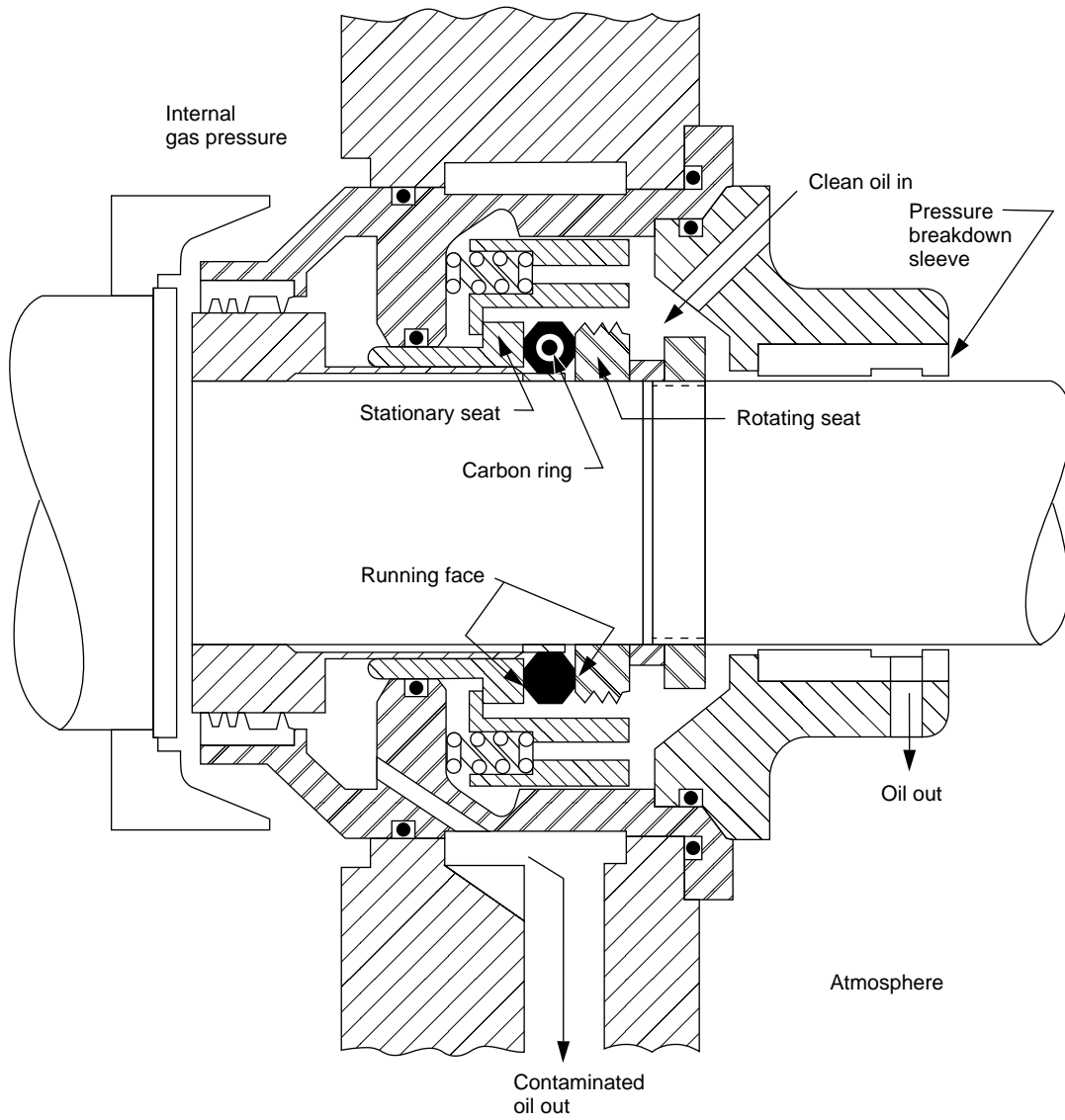

Figure 1.C-2— Mechanical (Contact) Shaft Seal

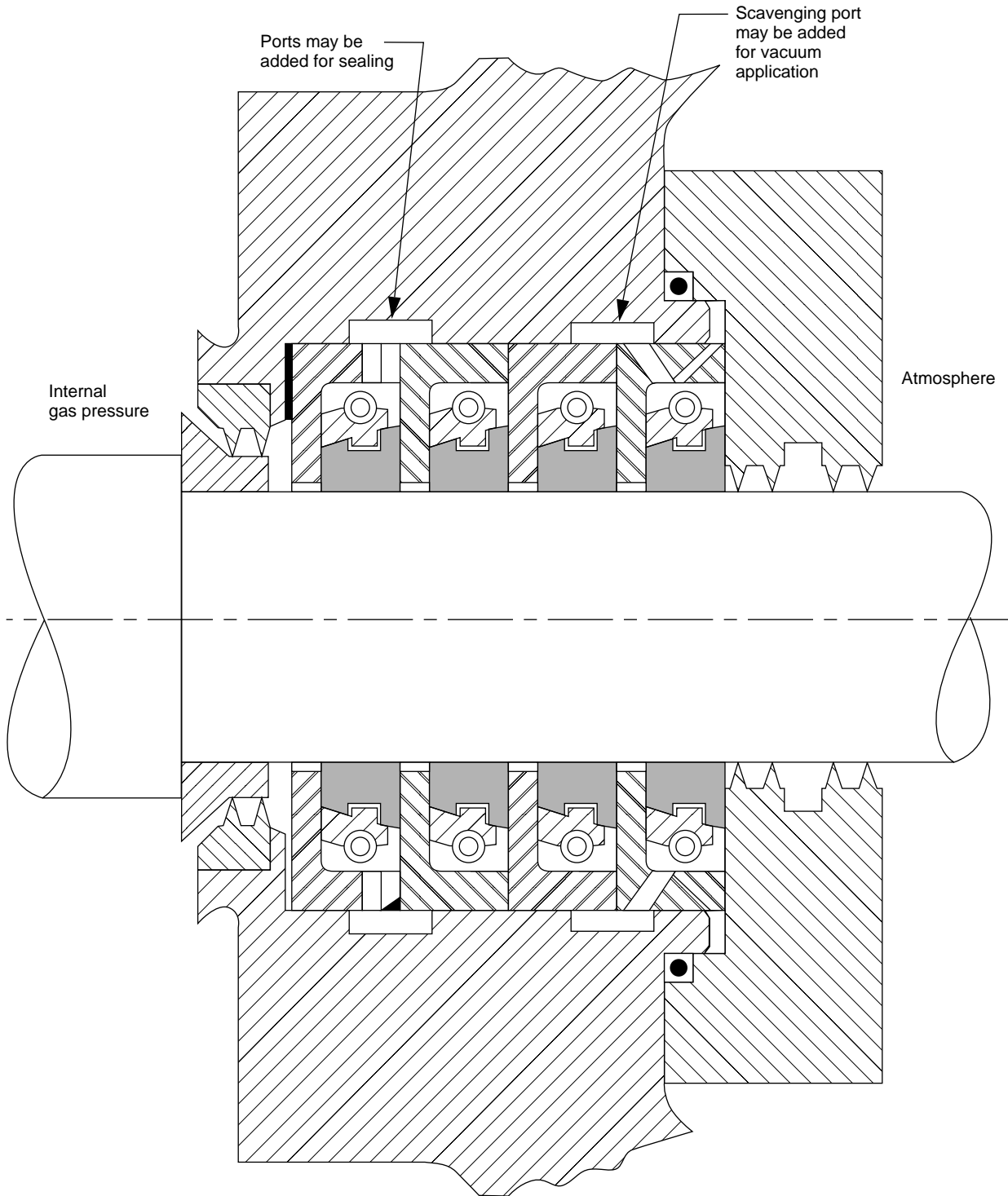

Figure 1.C-3—Restrictive-ring Shaft Seal

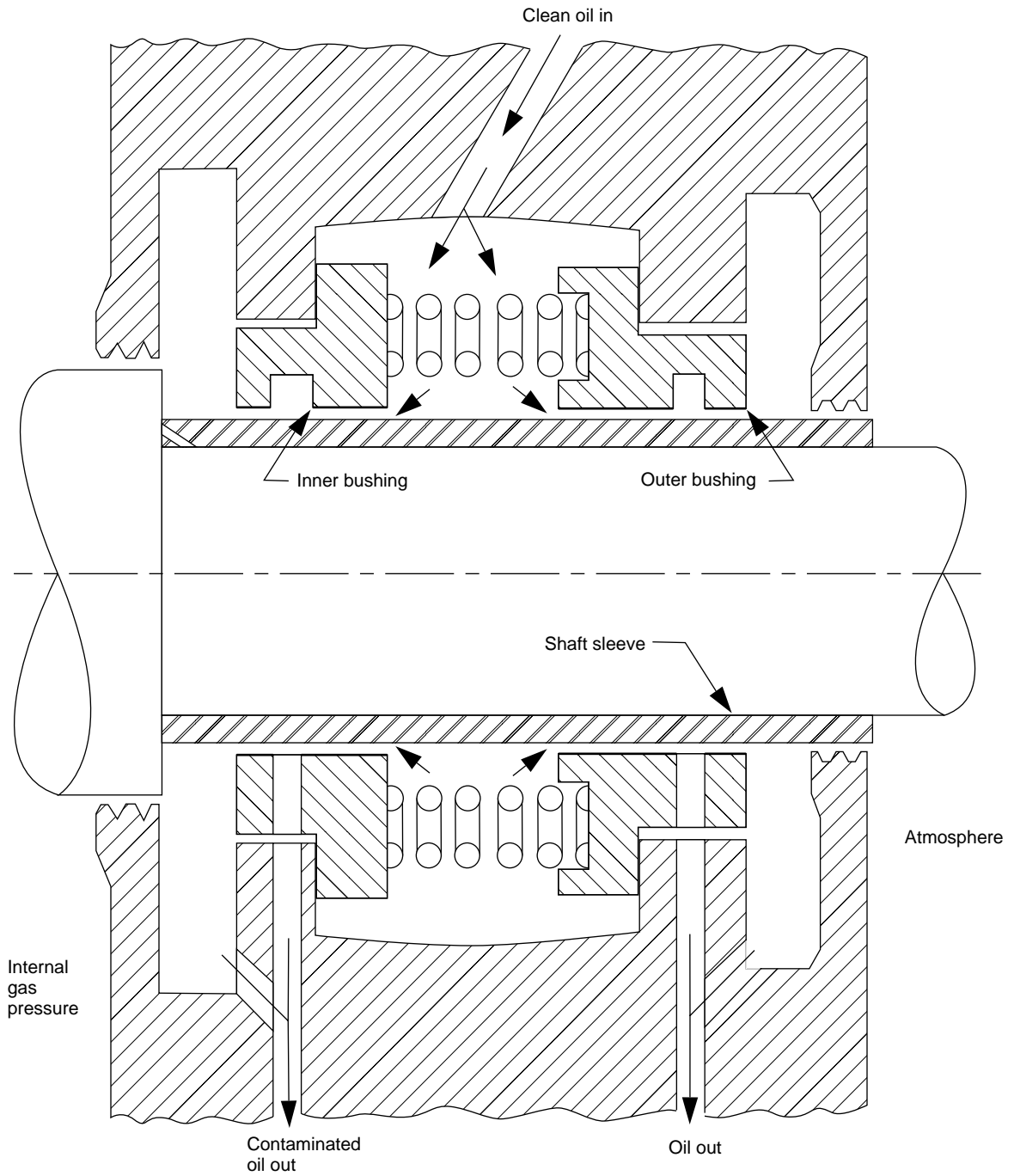

Figure 1.C-4—Liquid-film Shaft Seal with Cylindrical Bushing

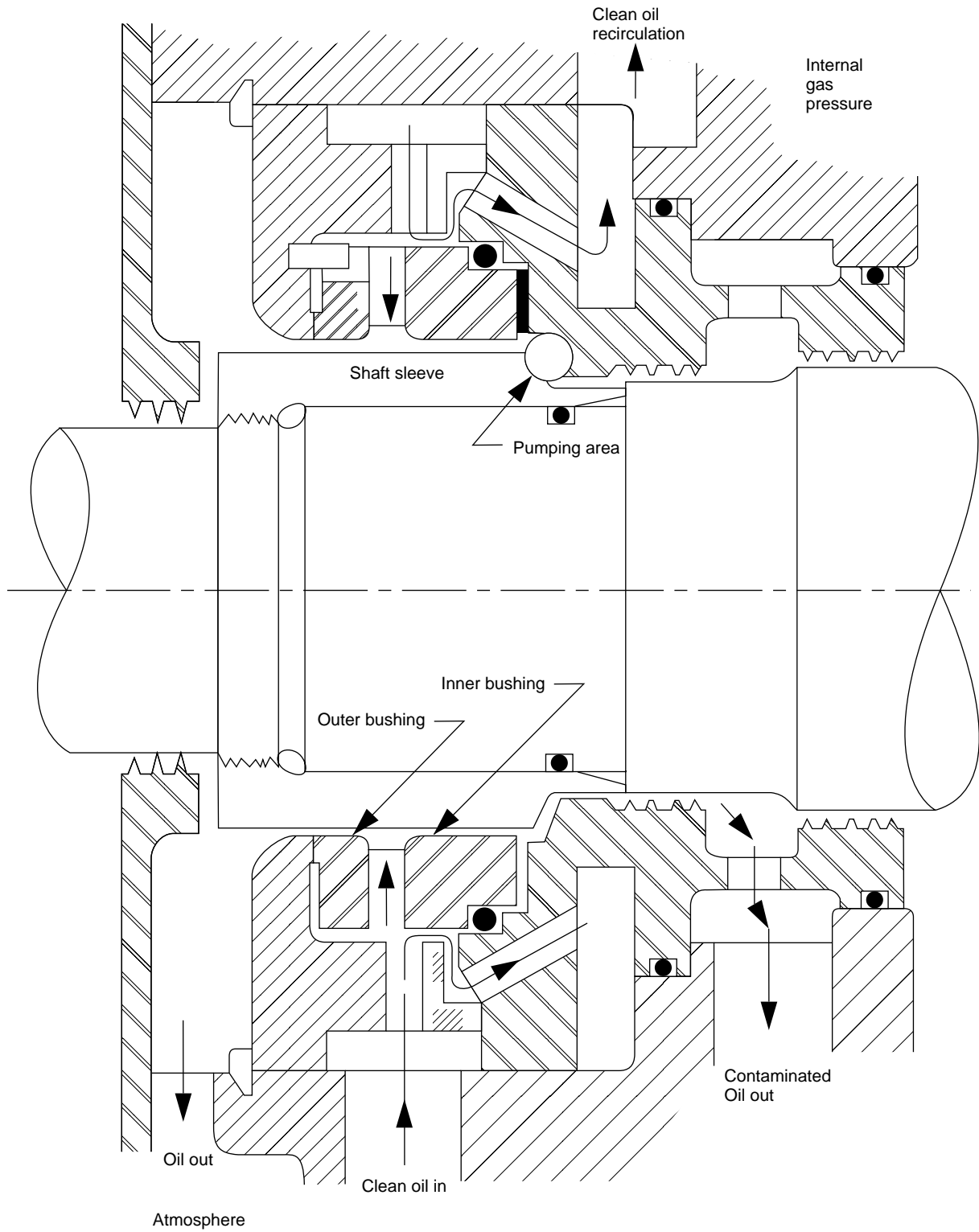

Figure 1.C-5—Liquid-film Shaft Seal with Pumping Brush

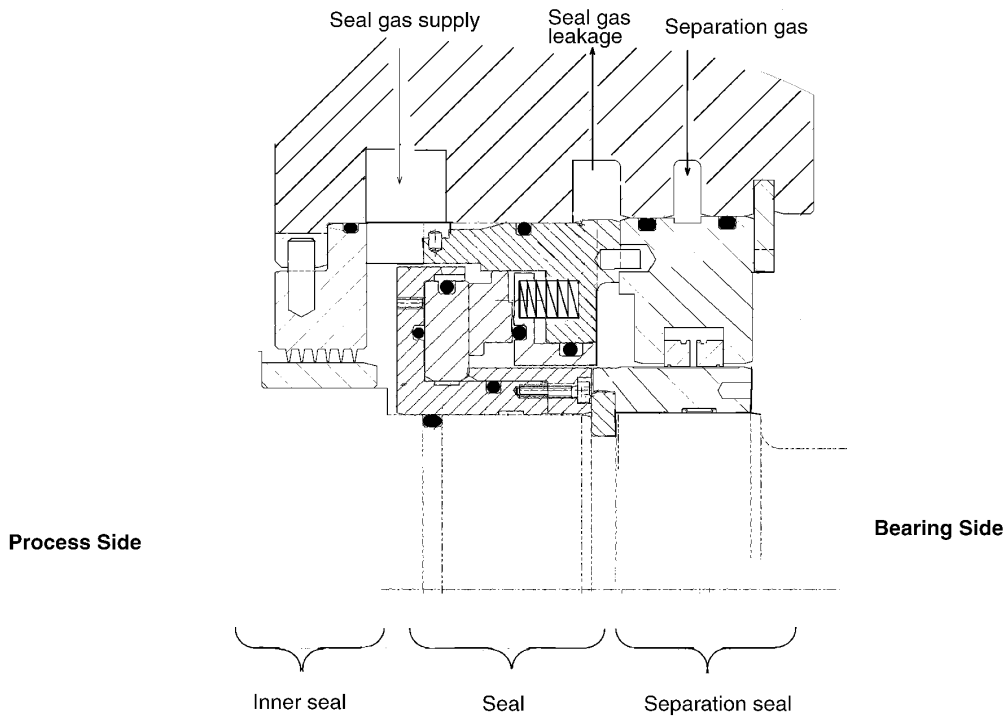

Figure 1.C-6—Single Gas Seal

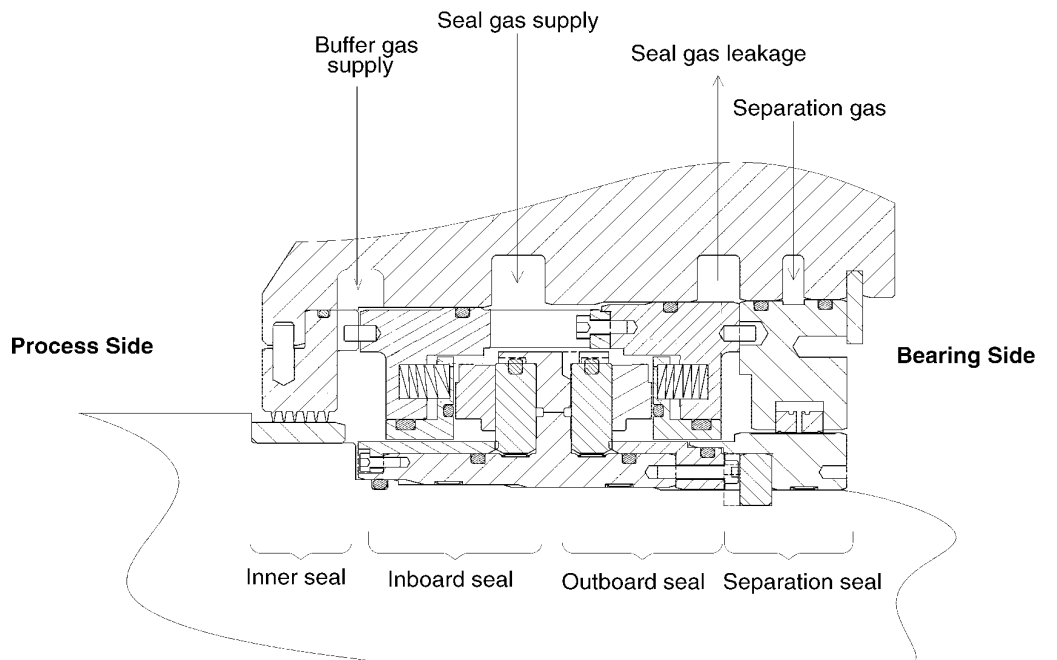

Figure 1.C-7—Double Gas Seal

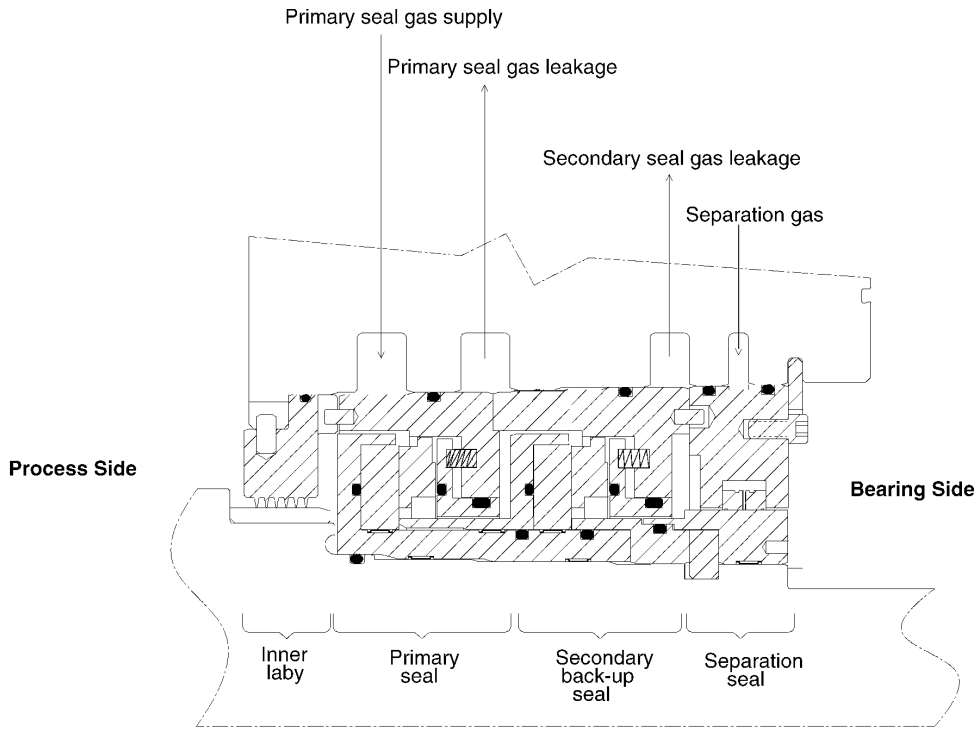

Figure 1.C-8—Tandem Gas Seal

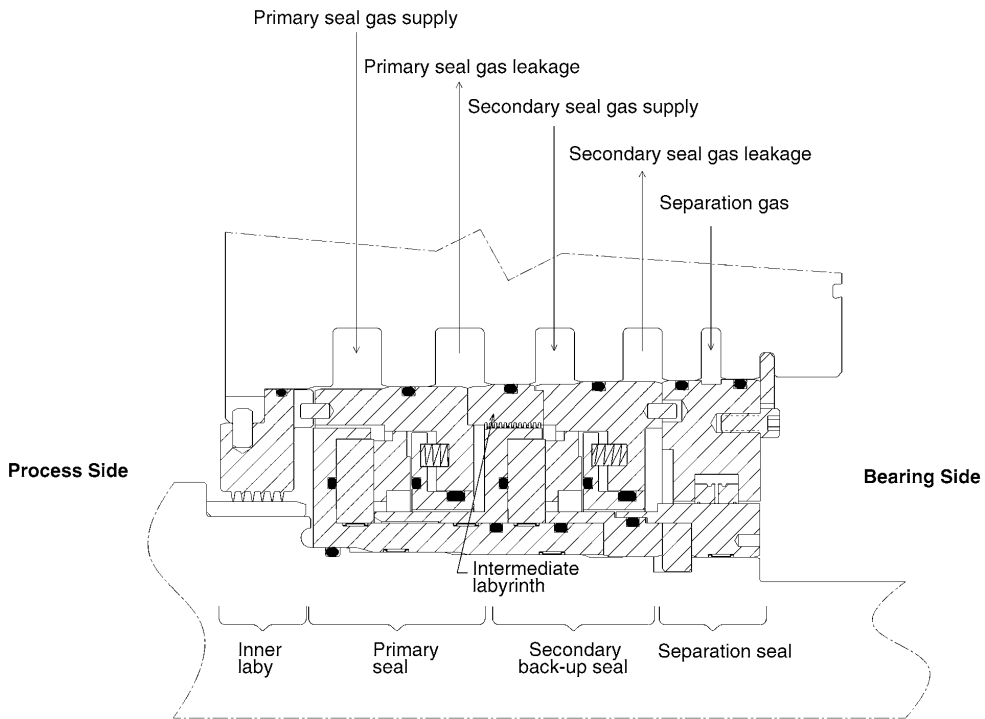

Figure 1.C-9—Tandem Gas Seal with Labyrinth

ANNEX 1D
TESTING OF GAS SEALS IN SEAL VENDOR'S SHOP
(NORMATIVE)

This test procedure shall be followed on every purchased dry gas seal using the manufacturer's test rig to verify seal performance. The test shall contain the following as a minimum:

1. The following data shall be recorded as required in 2—Static Test Pressure or 3—Dynamic Test Procedure of this annex.

- a. Time at which data is recorded.
- b. Seal gas temperature and pressure; and leakage flows (as read and as corrected to standard conditions).
- c. Static (breakaway) and test point torque.
- d. Process or test stand temperature and pressure.
- e. Seal gas leakage associated with the tandem seal primary and secondary outer leakage.
- f. Test speed in rpm.
- g. Power consumption (minus tare, if significant).

2. Static Test Procedure

- a. Set the primary seal gas pressure to the maximum specified static seal gas pressure. Hold this pressure for a minimum of 10 min. and record data. Reduce the pressure to 75%, 50% and 25% of the maximum specified static seal gas pressure. Hold at each pressure level and record static leakage at each step.
- b. Set the secondary seal gas pressure to the maximum specified static seal gas pressure. Hold this pressure for a minimum of 10 min. and record data. Reduce the pressure to 75%, 50% and 25% of the maximum specified static seal gas pressure. Hold at each pressure level and record static leakage at each step.

3. Dynamic Test Procedure

- a. With the seal gas at the maximum specified pressure and temperature, and the primary vent at the minimum specified back pressure, increase the speed from stand still to maximum continuous speed (MCS) and run for at least 15 min., or until the primary seal leakage reaches steady state. Record data.
- b. Increase the speed to trip speed (if higher than MCS) and run at least 15 min. Record data at 5-min. intervals.
- c. Reduce the speed to MCS and run for at least 1 hour, recording data at 5-min. intervals. The average primary

leakage must be less than the maximum allowable leakage that was specified.

d. Increase the primary vent back pressure to the maximum value specified and run for at least 15 min. Record data.

e. Increase the primary vent back pressure (secondary seal gas pressure) to the maximum specified seal gas pressure. This may require the primary seal gas pressure to be increased to maintain a minimum ΔP on the primary seal. Run for at least 15 min. Record data at 5-min. intervals.

Note: The compressor manufacturer, based on his own standards and/or the user specification, can specify the seal gas temperature as the seal manufacturer's standard, if that has been proved acceptable, or the maximum seal gas temperature anticipated in the field. This may vary widely, and a judgement needs to be made by the purchaser of the seal as to whether the seal gas temperature in the field will be high enough that it should be simulated in the seal test.

f. Perform two consecutive shutdowns and restarts to maximum continuous speed as fast as possible to trip speed and then reducing the speed to maximum continuous speed. Hold the speed for 5 min. or until the leakage reaches steady state. Record a complete set of data at rest and at speed. Maintain primary seal gas pressure and secondary seal gas pressure from item e above.

g. Shut down the rig and maintain specified seal gas conditions. Record two consecutive sets of data immediately following shutdown.

4. Visual Inspection

- a. Following the test, disassemble the seal while insuring that all critical parts are match-marked with respect to circumferential orientation and examine components for wear, buildup, and general condition.
- b. Tabulate condition on "prepared form" and make it part of the summary report.

5. Static Test Verification

- a. Reassemble the seal paying particular attention to match marks and replace it in the test rig.
- b. Repeat 2—Static Test Pressure.

ANNEX 1E TYPICAL MATERIAL SPECIFICATIONS (INFORMATIVE)

Note: This annex is an informative annex giving typical materials used for various compressor and expander components. There is no attempt to specify materials to more detail than their commercial material designation. Specific heat treatment, actual chemical analysis, and other specialized material properties are not addressed. Materials not shown in the annex, while they may not be typical, may or may not be acceptable for a particular application.

Table 1.E-1—Typical Material Specifications for Major Component Parts

Part	Material ^a	Specification ^b	Form	Temperature Limits ^c				
				Minimum °C (°F)	Maximum °C (°F)			
Casings								
Cast	Cast iron	ASTM A 278, Class 30	Cast	−45 (−50)	230 (450)			
		ASTM A 278, Class 40	Cast	−28 (−20)	260 (500)			
	Austenitic cast iron	ASTM A 436, Type 2	Cast	−45 (−50)	260 (500)			
		ASTM A 571, Type D-2M Classes 1 & 2	Cast	−195 (−320)	260 (500)			
	Ductile iron	ASTM A 395	Cast	−28 (−20)	260 (500)			
	Cast steel	ASTM A 216, Grade WCB ^d	ASTM A 352, Grade LCB	Cast	−45 (−50)	345 (650)		
			ASTM A 352, Grade LC2	Cast	−75 (−100)	345 (650)		
			ASTM A 352, Grade LC3	Cast	−100 (−150)	345 (650)		
			ASTM A 352, Grade LC4	Cast	−115 (−175)	345 (650)		
			ASTM A 352, Grade LCC	Cast	−45 (−50)	345 (650)		
			ASTM A 217	Cast	−28 (−20)	400 (750)		
			ASTM A 217	Cast	−28 (−20)	400 (750)		
	Cast stainless steel	ASTM A 743/744 or A 351, Grade CF3, CF3M, CF8 or CF8M	Cast	−195 (−320)	345 (650)			
		ASTM A 351, Grade CF3MA or CF8MA	Cast	−195 (−320)	345 (650)			
	Cast aluminum	ASTM A 356 or A 357	Cast	−195 (−320)	150 (300)			
Cast titanium	ASTM B 367, Grade C3 or C4	Cast	−45 (−50)	150 (300)				
Fabricated	Steel	ASTM A 285, Grade C	Plate	−45 (−50)	345 (650)			
		ASTM A 516, Grade 55, 60, 65, 70	Plate	−45 (−50)	345 (650)			
		ASTM A 203, Grade A or B	Plate	−60 (−75)	345 (650)			
		ASTM A 203, Grade D or E	Plate	−105 (−160)	345 (650)			
		ASTM A 537, Class 1 or 2	Plate	−60 (−75)	345 (650)			
		ASTM A 353	Plate	−195 (−320)	345 (650)			
		ASTM A 553, Type I	Plate	−195 (−320)	345 (650)			
		ASTM A 553, Type II	Plate	−170 (−275)	345 (650)			
		ASTM A 266, Class 1 or 4	Forged	−28 (−20)	345 (650)			
		ASTM A 336, Class F1	Forged	−28 (−20)	345 (650)			
		ASTM A 414	Sheet	−28 (−20)	345 (650)			
		ASTM A 508, Class 5a	Forged	−28 (−20)	345 (650)			
		ASTM A 350, Grade LF2	Forged	−45 (−50)	345 (650)			
		ASTM A 350, Grade LF3	Forged	−100 (−150)	345 (650)			
		Stainless steel	ASTM A 240, Type 304, 304L, 316, 316L or 321	Plate	−195 (−320)	345 (650)		
			ASTM A 182, Grade F304, F304L, F316 or F321	Forged	−195 (−320)	345 (650)		
		Aluminum	ASTM B 209, Alloy 6061 or 7075	Plate	−195 (−320)	150 (300)		
			ASTM B 211, Alloy 6061 or 7075	Bar	−195 (−320)	150 (300)		
			ASTM B 247, Alloy 6061 or 7075	Forged	−195 (−320)	150 (300)		
			AMS 4108, Alloy 7050	Forged	−195 (−320)	150 (300)		
		Diaphragms, guide vanes and inner casings	Cast iron	ASTM A 48 or A 278, Class 30	Cast	−195 (−320)	345 (650)	
				Ductile iron	ASTM A 536	Cast	−195 (−320)	345 (650)
				Cast iron	ASTM A 216, Grade WCB	Cast	−195 (−320)	345 (650)

Table 1.E-1—Typical Material Specifications for Major Component Parts

Part	Material ^a	Specification ^b	Form	Temperature Limits ^c		
				Minimum °C (°F)	Maximum °C (°F)	
	Steel	ASTM A 283, A 284, A 285, A 516 or A 543	Plate	– 195 (– 320)	345 (650)	
	Stainless steel	ASTM A 36	Plate	– 195 (– 320)	345 (650)	
		ASTM A 743/744 or A 351, Grade CA15, CF3, CF3M, CF8 or CF8M	Cast	– 195 (– 320)	345 (650)	
		ASTM A 240, Type 410	Plate	– 195 (– 320)	345 (650)	
		ASTM A 276, Type 410	Bar	– 195 (– 320)	345 (650)	
	Aluminum	ASTM B 26, Alloy 355 or C355	Cast	– 195 (– 320)	145 (300)	
Shaft	Steel	ASTM A 470, Class 1	Forged	– 28 (– 20)	345 (650)	
		ASTM A 470, Class 7	Forged	– 115 (– 175)	400 (750)	
		AISI Types 1040 – 1050 ^c	Bar or Forged	– 28 (– 20)	345 (650)	
		AISI Types 4140 – 4150 ^c	Bar or Forged	– 28 (– 20)	400 (750)	
		AISI Type 2320 ^c	Bar or Forged	– 110 (– 170)	345 (650)	
		ASTM A 522, Type 1	Forged	– 195 (– 320)	345 (650)	
	Stainless steel	ASTM 4340 – 4345	Forged	– 115 (– 175)	345 (650)	
		ASTM A 336, Grade F6	Forged	– 60 (– 75)	345 (650)	
		ASTM A 473, Type 410	Forged	– 60 (– 75)	345 (650)	
		ASTM A 705, Types 630 or XM-12	Forged	– 75 (– 100)	345 (650)	
	Precipitation hardening stainless steel	ASTM A 564, Type 630 or XM-12	Bar	– 270 (– 454)	345 (650)	
	Impellers	Aluminum	ASTM B 26, Alloy C355	Cast	– 195 (– 320)	150 (300)
	Cast	Precipitation hardening stainless steel	ASTM A 747, Type CB7CU-1 or CB7CU-2	Cast	– 75 (– 100)	345 (650)
Steel			ASTM A 148	Cast	– 28 (– 20)	345 (650)
Stainless steel		ASTM A 487 Gs 4Q	Cast	– 45 (– 50)	345 (650)	
		ASTM A 743/744 or A 351, Grade CA15 or CA6NM	Cast	– 45 (– 50)	345 (650)	
		ASTM A 743/744 or A 351, Grade CF3, CF3M, CF8 or CF8M	Cast	– 195 (– 320)	345 (650)	
Aluminum		ASTM A 356 or A 357	Cast	– 195 (– 320)	150 (300)	
Titanium		ASTM B 367, Grade C3 or C4	Cast	– 45 (– 50)	345 (650)	
		ASTM B 367, Grade C5	Cast	– 195 (– 320)	345 (650)	
Fabricated (covers, hubs, blades)		Aluminum	ASTM B 209, Alloy 6061 or 7075	Plate	– 195 (– 320)	150 (300)
			ASTM B 211, Alloy 6061 or 7075	Bar	– 195 (– 320)	150 (300)
	ASTM B 221, Alloy 6061 or 7075		Extruded	– 195 (– 320)	150 (300)	
	ASTM B 247, Alloy 2618, 6061 or 7075		Forged	– 195 (– 320)	150 (300)	
	AMS 4108, Alloy 7050		Forged	– 195 (– 320)	150 (300)	
	Steel		AISI Types 4130 – 4140 ^c	Plate or Forged	– 28 (– 20)	400 (750)
	Steel	AISI Types 4320 – 4345 ^c	Plate or Forged	– 115 (– 175)	400 (750)	
		AISI Type 3140 ^c	Forged	– 45 (– 50)	400 (750)	
		ASTM A 543	Plate	– 115 (– 175)	400 (750)	

Table 1.E-1—Typical Material Specifications for Major Component Parts

Part	Material ^a	Specification ^b	Form	Temperature Limits ^c	
				Minimum °C (°F)	Maximum °C (°F)
		ASTM A 522, Type I	Forged	– 145 (– 230)	345 (650)
		ASTM A 522, Type II	Forged	– 170 (– 275)	345 (650)
		ASTM A 353	Plate	– 195 (– 320)	345 (650)
		AISI Type 403 ^c	Forged	– 60 (– 75)	345 (650)
		ASTM A 473 Type 410	Forged	– 60 (– 75)	345 (650)
		ASTM A 240 Type 304, 304L, 316 or 316L	Plate	– 195 (– 320)	345 (650)
		ASTM A 473 Type 304, 304L, 316, or 316L	Forged	– 195 (– 320)	345 (650)
		UNS S42400	Forged	– 101 (– 150)	345 (650)
	Precipitation harden- ing stainless steel	ASTM A 705, Type 630 or XM-12	Forged	– 75 (– 100)	345 (650)
		ASTM A 693, Type 630 or XM-12	Plate	– 75 (– 100)	345 (650)
	Ni-Cu	SAE AMS 4646	Forged	– 115 (– 175)	345 (650)
		ASTM B 127	Plate	– 115 (– 175)	345 (650)
		QQ-N-286	Plate	– 115 (– 175)	345 (650)
Labyrinths					
Impeller interstage shaft seal and balance piston	Aluminum	ASTM B 26, Alloy 443, 335, 850, A850 or B850	Cast	– 195 (– 320)	315 (600)
		6061-T6 or 1100	Plate	– 195 (– 320)	315 (600)
	Babbitt	ASTM B 23	Cast	– 195 (– 320)	175 (350)
	Brass	ASTM B 16 or B 21	Rod, bar	– 195 (– 320)	150 (300)
		ASTM B 36	Plate, bar	– 195 (– 320)	150 (300)
		ASTM B 171	Plate	– 195 (– 320)	150 (300)
	Stainless steel	AISI Type 403, 410, 416, 303, 304 or 316	Wrought	– 195 (– 320)	345 (650)
	Cr-Ni-Fe-Mo-Cu-Cb alloy	ASTM B 462	Wrought	– 195 (– 320)	345 (650)
	Stainless steel honeycomb	ASTM A 240, Type 304, 304L, 316 or 316L	Fabricated	– 195 (– 320)	345 (650)
	Ni-Cu alloy	ASTM B 164	Wrought	– 115 (– 175)	345 (650)
	Nonmetallic TFE ^f		Molded	– 195 (– 320)	260 (500)
	Nonmetallic TFE ^f carbon-filled		Molded	– 28 (– 20)	260 (500)
	Nonmetallic TFE ^f mica-filled		Molded	– 54 (– 65)	260 (500)
	Lead	ASTM B 29	Cast	– 101 (– 150)	205 (400)
	Nickel-graphite		Coating	– 101 (– 150)	482 (900)
	Phenolic resin impregnated materials	Micarta, NEMA, Grade LE	Sheet	– 195 (– 320)	65 (130)
		Micarta, NEMA, Grade G10 or G9	Sheet	– 195 (– 320)	110 (230)
Balance piston	Steel (new)	ASTM A 470, Class 1	Forged	– 28 (– 20)	345 (650)
		ASTM A 470, Class 7	Forged	– 115 (– 175)	400 (750)
		AISI Types, 1040 – 1050 ^c	Forged	– 28 (– 20)	345 (650)
		AISI Types, 4130 – 4145 ^c	Forged	– 28 (– 20)	400 (750)
		AISI Types 4330, 4345 ^c	Forged	– 115 (– 175)	455 (850)
		AISI Type 2320 ^c	Forged	– 112 (– 170)	345 (650)

Table 1.E-1—Typical Material Specifications for Major Component Parts

Part	Material ^a	Specification ^b	Form	Temperature Limits ^c		
				Minimum °C (°F)	Maximum °C (°F)	
	Stainless steel (new)	ASTM A 522, Type I	Forged	– 195 (– 320)	345 (650)	
		ASTM A 336, Grade F6	Forged	– 60 (– 75)	345 (650)	
		ASTM A 473, Type 410	Forged	– 60 (– 75)	345 (650)	
	Precipitation hardening stainless steel	AISI Type 403 or 410 ^e	Forged	– 28 (– 20)	345 (650)	
		ASTM A 705, Type 630 or XM-12	Forged	– 75 (– 100)	345 (650)	
		Ni-Cu alloy	SAE AMS 4676	Forged	– 115 (– 175)	345 (650)
Shaft sleeves	Steel	AISI Types 4130 – 4150 ^e	Forged	– 45 (– 50)	345 (650)	
		AISI Types 4320 – 4345 ^e	Forged	– 115 (– 175)	400 (750)	
		ASTM A 470, Class 7	Forged	– 115 (– 175)	400 (750)	
		ASTM A 522, Type I	Forged	– 195 (– 320)	345 (650)	
		ASTM A 106	Pipe	– 28 (– 20)	345 (650)	
		ASTM A 350	Forged	– 45 (– 50)	345 (650)	
	Stainless steel	ASTM A 350, Grade LF-3	Forged	– 100 (– 150)	345 (650)	
		AISI Types 403 or 410 ^e	Forged	– 75 (– 100)	400 (750)	
		Ni-Cu alloy	ASTM B 164 or SAE AMS 4676	Forged	– 115 (– 175)	345 (650)
		Ni-Mo-Cr alloy	ASTM B 574, Alloy N10276	Wrought	– 115 (– 175)	345 (650)
			ASTM A 494, Grade CW-12M-1	Cast	– 115 (– 175)	345 (650)
Precipitation hardening stainless steel	A 705 Type 630 or XM-12	Forged	– 75 (– 100)	345 (650)		

Notes:

^aThe materials shown in this table are those commonly used by compressor manufacturers, but the list is not all inclusive. Other suitable materials may exist and may be used as indicated by specific design considerations.

^bDescriptions of AISI Types can be found in ASTM DS 56D. See Note “e”.

^cThe temperature limits shown in this table are those commonly observed by compressor manufacturers and are not necessarily the same as any temperature limits specified in the applicable material specifications.

^dNormalized or normalized and tempered.

^eAISI designations are only a description of chemical analyses of types of steel; they are not procurement specifications. All materials should be purchased to a specification that adequately defines the required properties and controls.

^fTFE = tetrafluoroethylene.

Chapter 2

Centrifugal and Axial Compressors

Copyright 2003 American Petroleum Institute

.....

CONTENTS

	Page
SECTION 1—GENERAL	2-1
1.1 Scope	2-1
1.2 Definition of Terms	2-1
SECTION 2—BASIC DESIGN	2-1
2.1 General	2-1
2.2 Materials	2-1
2.3 Casings	2-1
2.4 Guide Vanes, Stators, and Stationary Internals	2-4
2.5 Rotating Elements	2-4
2.6 Dynamics	2-5
2.7 Bearings and Bearing Housings	2-5
2.8 Shaft End Seals	2-6
2.9 Gears	2-7
2.10 Lubrication and Sealing Systems	2-7
2.11 Nameplates and Rotation Arrows	2-7
SECTION 3—ACCESSORIES	2-7
3.1 Drivers	2-7
3.2 Couplings and Guards	2-7
3.3 Mounting Plates	2-7
3.4 Controls and Instrumentation	2-7
3.5 Piping and Appurtenances	2-8
3.6 Special Tools	2-8
SECTION 4—INSPECTION, TESTING, AND PREPARATION FOR SHIPMENT	2-8
4.1 General	2-8
4.2 Inspection	2-8
4.3 Testing	2-8
4.4 Preparation for Shipment	2-10
SECTION 5—VENDOR'S DATA	2-11
5.1 General	2-11
ANNEX 2A TYPICAL DATA SHEETS	2-13
ANNEX 2B CENTRIFUGAL AND AXIAL COMPRESSOR VENDOR DRAWING AND DATA REQUIREMENTS	2-25
ANNEX 2C CENTRIFUGAL AND AXIAL COMPRESSOR NOMENCLATURE	2-33
ANNEX 2D INSPECTOR'S CHECK LIST	2-37
ANNEX 2E FORCES AND MOMENTS	2-41
Figures	
2.1-1a Illustration of Terms	2-2
2.1-1b Axial Compressor Map with Variable Speed	2-3
2.1-1c Axial Compressor Map with Variable Stator Vanes	2-3
2.C-1 Typical Centrifugal Compressor Showing Nomenclature of Key Parts	2-34
2.C-2 Typical Axial Compressor Showing Nomenclature of Key Parts	2-35
2.E-1 Combined Resultants of the Forces and Moments of Corrections	2-43

01/19/2003 01:14:13 MST

SECTION 1—GENERAL

1.1 SCOPE

This chapter, in conjunction with Chapter 1 of this standard, covers the minimum requirements for centrifugal and axial compressors for pipeline or process air or gas services.

Note: See Chapter 3 of this standard for integrally geared process compressors, or API Std 672 for packaged plant instrument air compressors.

1.2 DEFINITION OF TERMS

Definitions of terms used in this chapter may be found in Chapter 1 of this standard. A cross-section showing nomenclature of a centrifugal compressor, overhung compressor and axial compressor may be found in Annex 2C.

Note: Figure 2.1-1a is a typical operating map for a centrifugal compressor. Figures 2.1-1b and 2.1-1c are typical operating maps for an axial compressor.

SECTION 2—BASIC DESIGN

2.1 GENERAL

2.1.1 Performance

2.1.1.1 The sectional head-capacity characteristic curve shall rise continuously from the rated point to predicted surge. The compressor, without the use of a bypass, shall be suitable for continuous operation at any capacity at least 10% greater than the predicted surge capacity shown in the proposal.

Note: Axial compressor manufacturers may also require an overload limit due to blade stresses (see 3.4.2.1).

2.2 MATERIALS

Materials shall be in accordance with 2.2 of Chapter 1 of this standard. Refer to Annex 1E for a table of typical materials.

2.3 CASINGS

Casings shall be in accordance with 2.3 of Chapter 1 and 2.3.1 through 2.3.4, as follows.

2.3.1 Pressure-containing Casings

- **2.3.1.1** The purchaser will specify the relief valve setting. The maximum allowable working pressure of the casing shall be at least equal to the specified relief valve setting.

2.3.1.1.1 When a relief valve setting is not specified, the maximum allowable working pressure shall be at least 1.25 times the maximum specified discharge pressure (gauge). System protection shall be furnished by the purchaser.

2.3.1.2 Casings designed for more than one maximum allowable pressure level (split pressure-level casings) are permitted only in process air service with an atmospheric pressure inlet. Split pressure-level casings are not permitted in other services unless specifically approved by the purchaser. If approved, the vendor shall define the physical limits and the maximum allowable working pressure of each section of the casing.

2.3.1.3 Unless otherwise specified, casings shall be radially split when the partial pressure of hydrogen (at maximum allowable working pressure) exceeds 1380 kPa gauge (200 psi gauge). The partial pressure of hydrogen shall be calculated by multiplying the highest specified mole (volume) percent of hydrogen by the maximum allowable working pressure.

2.3.1.4 Each axially split casing shall be sufficiently rigid to allow removal and replacement of its upper half without disturbing rotor-to-casing running clearances and bearing alignment.

2.3.1.5 Axially split casings shall use a metal-to-metal joint (with a suitable joint compound) that is tightly maintained by suitable bolting. Gaskets (including string type) shall not be used on the axial joint. O-rings retained in grooves machined into the flange facing of an axially split casing joint may be used with purchaser's approval.

2.3.1.6 Radially split casings normally use "O" rings, gaskets or other sealing devices between the end head(s) and cylinder. These devices shall be confined in machined grooves, and they shall be made of materials suitable for all specified service conditions.

2.3.1.7 Socket-head, or spanner-type bolting shall not be used externally unless specifically approved by the purchaser.

2.3.2 Pressure Casing Connections

2.3.2.1 General

Casing connections will be in accordance with 2.3.2, in Chapter 1 of this standard.

2.3.2.2 Main Process Connections

2.3.2.2.1 Inlet and outlet connections for radially split machines shall be located in the outer casing, not in the end heads. On radially split overhung design machines, the process inlet connection may be in the end head.

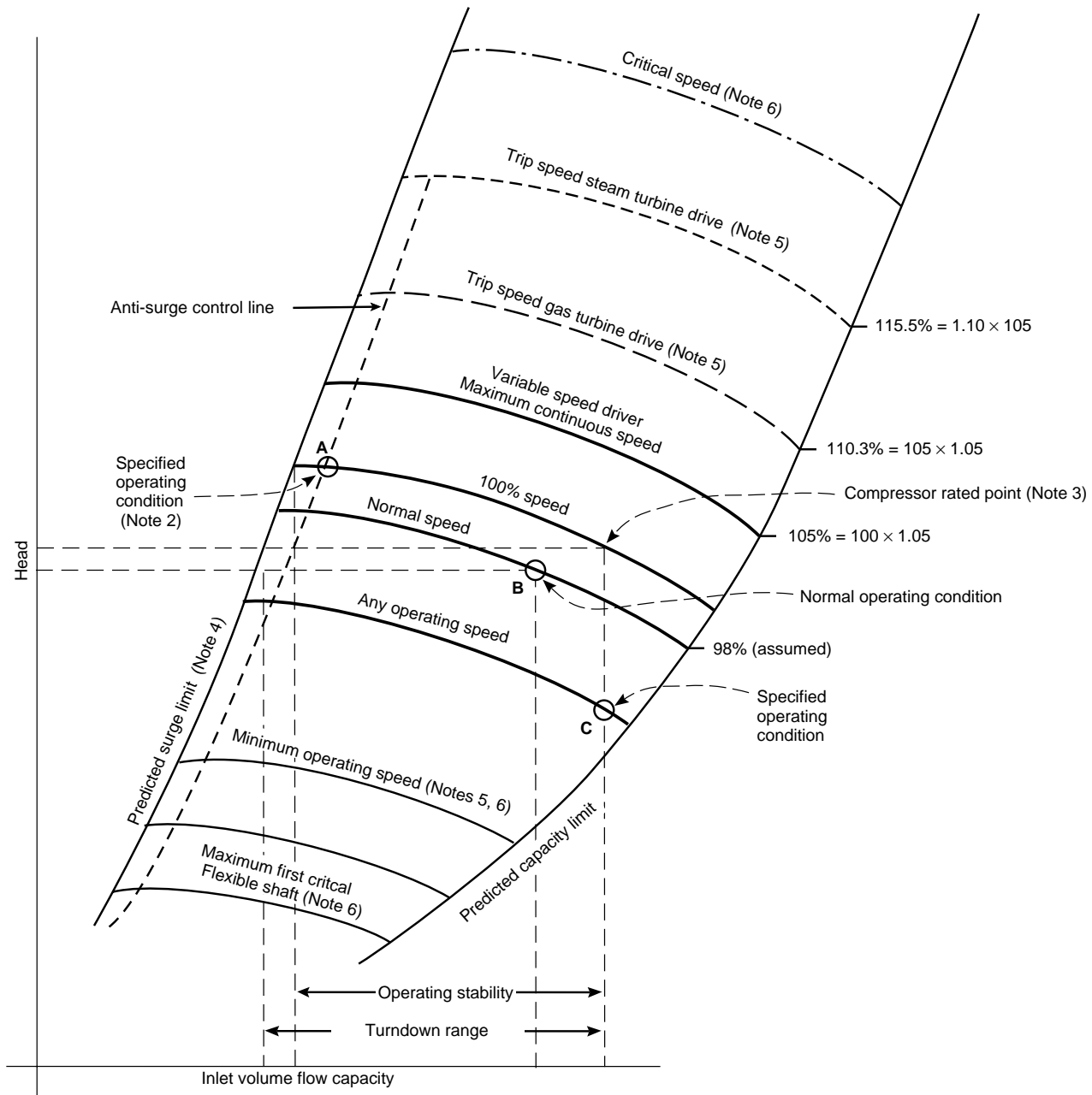

Notes:

1. Except where specific numerical relationships are stated, the relative values implied in this figure are assumed values for illustration only.
2. The 100% speed curve is determined from the operating point requiring the highest head; point A in the illustration.
3. The compressor rated point (CRP) is the intersection on the 100% speed line corresponding to the highest flow of any operating point; point C in the illustration.
4. The head-capacity curve at 100% speed shall extend to at least 115% of the capacity of the CRP. Head-capacity curves at other speeds shall be extended to equivalent capacity at each speed. For example, the head-capacity curve at 105% speed shall be extended to at least 1.05 times 1.15 times the capacity of the CRP; the head-capacity curve at 90% speed shall be extended at least 0.9 times 1.15 times capacity of the CRP; and so on. These points define the "approximate capacity limit" curve.
5. Refer to the applicable standard for the compressor driver such as API Std 612 or API Std 616 for trip speed and minimum operating speed limits.
6. Refer to 2.6.2.10 of Chapter 1 for allowable margins of critical speeds to operating speeds.

Figure 2.1-1a—Illustration of Terms

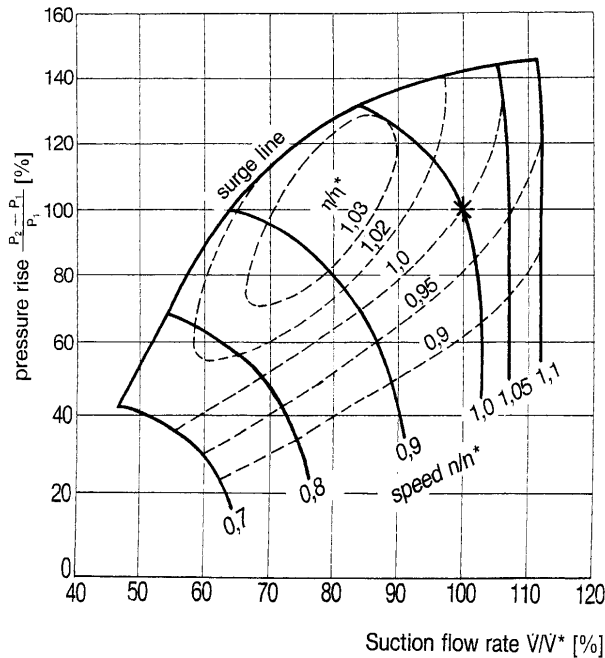

* rated point

Figure 2.1-1b—Axial Compressor Map with Variable Speed

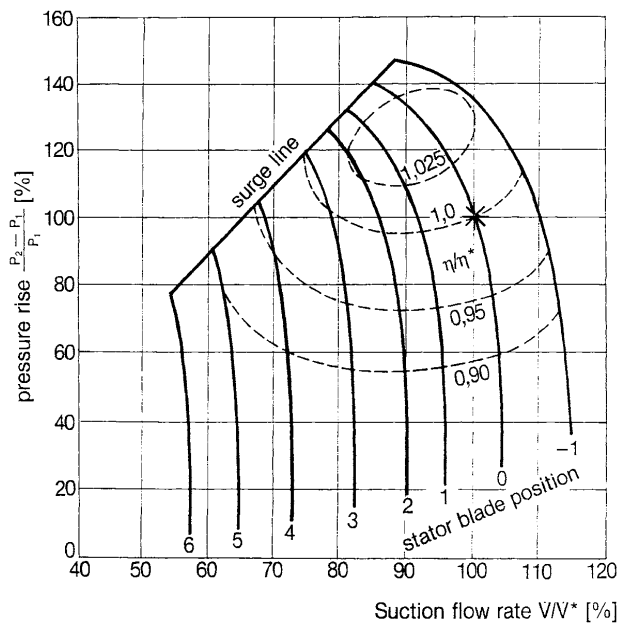

* rated point

Figure 2.1-1c—Axial Compressor Map with Variable Stator Vanes

2.3.2.3 Auxiliary Connections

2.3.2.3.1 Auxiliary connections shall be at least DN 20 ($3/4$ -in. nominal pipe size). For socket-welded construction, a 2-mm ($1/16$ -in.) gap, as measured prior to welding, shall be left between the pipe end and the bottom of the socket in the casing.

Note: See 2.3.2.1.3 of Chapter 1 for allowable connection sizes.

2.3.2.3.2 Threaded connections for pipe sizes DN 20 ($3/4$ -in. NPT) through DN 40 ($1\frac{1}{2}$ -in. NPT) size are permissible with the approval of the purchaser.

Note: See 2.3.2.3.5 of Chapter 1 for additional requirements.

- **2.3.2.4** When specified, connections for borescopic examination shall be supplied in mutually agreeable locations.

2.3.3 Casing Support Structure

2.3.3.1 Mounting surfaces shall meet the following criteria:

1. They shall be machined to a finish of $6\ \mu\text{m}$ ($250\ \mu\text{in.}$) arithmetic average roughness (Ra) or better.
2. Each mounting surface shall be machined within a flatness of $13\ \mu\text{m}$ per 330 linear mm ($.0005\ \text{in.}$ per linear ft) of mounting surface.
3. Different mounting planes shall be parallel to each other within $50\ \mu\text{m}$ ($.002\ \text{in.}$) over the distance between mounting surfaces.
4. The upper machined or spot-faced surface shall be parallel to the mounting surface.

Hold-down bolt holes shall be perpendicular to the equipment mounting feet and drilled 12 mm ($1/2\ \text{in.}$) larger in diameter than the hold down bolt to allow for final alignment. Mounting surfaces will be spot faced to a diameter sufficiently large to accommodate a washer and to allow for final alignment.

2.3.3.2 The equipment feet shall be provided with vertical jack-screws and shall be drilled with pilot holes that are accessible for use in final doweling.

2.3.3.3 Supports and alignment bolts shall be rigid enough to permit the machine to be moved by the use of lateral and axial jackscrews provided on the mounting plate.

2.3.4 External Forces and Moments

2.3.4.1 The compressor shall be designed to withstand external forces and moments on each nozzle calculated per Equations 2.E-1a or 2.E-1b and 2.E-2 of Annex 2E. The vendor shall furnish the allowable forces and moments for each nozzle in tabular form.

2.3.4.2 Casing and supports shall be designed to have sufficient strength and rigidity to limit coupling movement caused by imposing allowable forces and moments to $50\ \mu\text{m}$ ($0.002\ \text{in.}$).

2.4 GUIDE VANES, STATORS, AND STATIONARY INTERNALS

- **2.4.1** When specified or required to meet specified operating conditions, Adjustable Inlet Guide Vanes (AIGVs) on centrifugal compressors or variable stators on axial compressors shall be supplied. All or some of the stator blade rows may be adjustable.
 - **2.4.2** When specified, the guide vane housing shall incorporate an external shell capable of providing an external purge of filtered air or inert gas.
 - **2.4.3** When specified, a vane control system consisting of a valve positioner with local position indicator and other components as specified shall be provided.
- 2.4.4** When provided, adjustable vanes or stators and operating mechanisms shall be suitable for all specified operating conditions, as well as start-up, shutdown, trip-out, settling-out, and momentary surge.
- 2.4.4.1** Guide vanes shall be mounted in replaceable bushings. Vanes may be positioned in the housing by replaceable permanently sealed anti-friction rolling element bearings if approved by the purchaser.
- 2.4.4.2** When inlet guide vanes or variable stators are used for toxic, flammable or explosive process gas, the linkage passing through the casing or enclosure shall be sealed to prevent leakage.
- 2.4.4.3** The inlet guide vanes shall be located as closely as possible to the eye of the impeller.
- 2.4.4.4** The vane foils shall have an aerodynamically smooth surface, especially where the shank enters the gas stream through the housing. A cantilevered design in lieu of a center supported vane design is preferred.
- 2.4.4.5** The vanes shall be designed such that the vanes will tend to open on loss of the control signal.
- **2.4.5** Interstage diaphragms shall be suitable for all specified operating conditions, including start-up, shutdown, trip-out, settling-out, and momentary surge. When intermediate main process connections are used, the purchaser will specify the maximum and minimum pressure at each connection. The vendor shall confirm that the diaphragms furnished are suitable for the maximum differential pressure.
- 2.4.6** Internal joints shall be designed to minimize leakage and permit easy disassembly.
- 2.4.7** Seals shall be provided at all internal close clearance points to minimize internal recirculation. Seal components shall be renewable or replaceable in order to restore design clearances.

2.4.8 Diaphragms shall be axially split unless otherwise approved by the purchaser. The diaphragms shall be furnished with threaded holes for eyebolts or with another means to facilitate removal.

2.4.9 Upper half diaphragms shall be fastened to the upper half casing or to each other in such a manner that they are lifted as a unit.

2.4.10 The internals (cartridge) of radially split compressors shall be designed for withdrawal from the outer shell and disassembly for inspection or replacement of parts.

2.5 ROTATING ELEMENTS

2.5.1 Each assembled rotor shall be clearly marked with a unique identification number. This number shall be on the non-drive end of the shaft or in another accessible area that is not prone to maintenance damage.

2.5.2 Unless other shaft protection is approved by the purchaser, renewable components shall be furnished at interstage close-clearance points. Sleeves, spacers or bushings shall be made of materials that are corrosion-resistant in the specified service.

2.5.2.1 Shaft sleeves shall be provided under shaft end seals. Sleeves shall be treated to resist wear and sealed to prevent gas leakage between the shaft and sleeve.

2.5.2.2 Shaft sleeves shall be provided under interstage seals. Closed impeller eye seals/bushings, which are stationary, do not require replaceable sleeves.

2.5.3 Shafts

2.5.3.1 Shafts for non through-bolt rotors shall be made of one-piece, heat treated steel that is suitably machined. Shafts that have a finished diameter larger than 200 mm (8 in.) shall be forged steel. Shafts that have a finished diameter of 200 mm (8 in.) or less shall be forged steel or hot rolled barstock, providing such barstock meets all quality and heat treatment criteria established for shaft forgings.

2.5.3.2 When modular (through bolt) rotors are provided the stub-shafts shall meet all quality and heat treatment criteria for shaft forgings. Refer to Annex 2C for rotor arrangements and nomenclature.

2.5.3.2.1 The studs or tie-bolts used to clamp a built-up rotor shall be made from bar or forgings. Threads shall be formed by rolling. Each tie-bolt shall be tested with a proof load corresponding to at least 110% of maximum stretch that occurs during assembly or in operation.

2.5.3.2.2 Magnetic particle or fluorescent penetrant inspection, performed subsequent to proof-load test, shall not reveal cracks, seams or laps.

2.5.3.3 Proven methods of axial compressor rotor construction shall be offered. This includes solid (one-piece), disk-on-shaft, or stub shaft using throughbolt, disk or drum construction, or other approved means.

2.5.4 Thrust Balancing

2.5.4.1 A balance piston, balance line, and porting shall be provided if required to reduce axial loads on the thrust bearings. A separate pressure-tap connection or connections shall be provided to indicate the pressure in the balancing chamber, not in the balance line.

2.5.4.2 The balance line, if required, shall be flanged and sized to handle balance piston gas leakage at twice the initial design seal clearance without exceeding the load rating of the thrust bearings (see 2.7.3.3). If the balance line involves a connection to purchaser's piping, then the connection size and locations shall be indicated on the data sheets.

- **2.5.4.3** When specified, a pressure tap connection shall be supplied in the downstream end of the balance line to allow measurement of differential pressure in the balance line.

Note: This connection may not be in the compressor supply, it might be in the process piping.

2.5.5 Impellers

2.5.6 Axial Compressor Rotor Blading

2.5.6.1 The blade natural frequencies shall not coincide with any source of excitation from 10% below minimum allowable speed to 10% above maximum continuous speed. If this is not feasible, blading shall be designed with stress levels low enough to allow unrestricted operation, at any specified operating speed for the minimum service life defined in 2.1.2 of Chapter 1. This shall be verified by Goodman diagrams or their equivalent. The vendor shall identify unacceptable speeds.

Note: Excitation sources include fundamental and first harmonic passing frequencies of rotating and stationary blades upstream and downstream of each blade row, gas passage splitters, irregularities in vane and nozzle pitch at horizontal casing flanges, and the first seven rotor speed harmonics.

2.5.6.2 For each blade row, the vendor shall present bending and torsional blade natural frequencies under both operating and static conditions by Campbell diagrams or their equivalent.

Note: Static frequencies can be used for comparison to "ring" testing on the blades installed in the rotor.

2.5.6.3 Axial compressor rotor blading may be attached via axial dovetail, tangential firtree, tangential T-slot, or via

radial entry with a conical seat. Other attachment methods are acceptable as approved by purchaser.

2.6 DYNAMICS

Dynamics shall be in accordance with 2.6 of Chapter 1.

2.7 BEARINGS AND BEARING HOUSINGS

2.7.1 General

2.7.1.1 Unless otherwise specified, hydrodynamic radial and thrust bearings shall be provided.

2.7.1.1.1 Unless otherwise specified, hydrodynamic bearings shall have flood lubrication.

- **2.7.1.1.2** When specified, active magnetic bearings shall be provided.

Note: Annex 4F gives application considerations for use of active magnetic bearings. These bearings are not specifically being recommended for equipment included in this chapter of this standard, although some users may decide to incorporate this technology into their units.

2.7.1.2 Thrust bearings and radial bearings shall be fitted with bearing-metal temperature sensors installed in accordance with API Std 670.

2.7.1.3 As a design criteria, bearing metal temperatures shall not exceed 100°C (212°F) at specified operating conditions with a maximum inlet oil temperature of 50°C (120°F). Vendors shall provide bearing temperature alarm and shutdown limits on the datasheets.

2.7.1.3.1 In the event that the above design criteria cannot be met, purchaser and vendor shall mutually agree on acceptable bearing metal temperatures.

2.7.2 Hydrodynamic Radial Bearings

2.7.2.1 Sleeve or pad radial bearings shall be used and shall be split for ease of assembly. The use of non-split designs requires the purchaser's approval. The bearings shall be precision bored with steel-backed babbitted replaceable liners, pads, or shells. The bearing design shall not require removal of the coupling hub to permit replacement of the bearing liners, pads, or shells unless approved by purchaser.

- **2.7.2.2** When specified, tilting pad bearings shoes shall be copper-alloy backed.
- **2.7.2.3** When specified, copper-alloy bearings shall have hardened steel inserts for support.

2.7.2.4 The bearing design shall suppress hydrodynamic instabilities and provide sufficient damping over the entire range of allowable bearing clearances to limit rotor vibration to the maximum specified amplitudes (see 2.6.8.8 of Chapter 1) while the equipment is operating loaded or unloaded, includ-

ing operation at any critical frequency within the specified operating speed range.

2.7.2.5 The removal of the top half of the casing of an axially split machine or the head of a radially split unit shall not be required for replacement of these elements.

2.7.3 Hydrodynamic Thrust Bearings

2.7.3.1 Thrust bearings shall be steel-backed, babbitted multiple segments designed for equal thrust capacity in both axial directions and arranged for continuous pressurized lubrication to each side. Both sides shall be tilting pads, incorporating a self-leveling feature, which ensures that each pad carries an equal share of the thrust load even with minor variation in pad thickness.

Note: Some low inlet pressure overhung compressors or axials may not need to meet the equal thrust load bi-directional criteria.

2.7.3.2 Hydrodynamic thrust bearings shall be selected at no more than 50% of the bearing manufacturer's ultimate load rating. The ultimate load rating is the load that will produce the minimum acceptable oil film thickness without inducing failure during continuous service, or the load that will not exceed the creep initiation or yield strength of the babbitt or bearing material at the location of maximum temperature on the pad, whichever load is less. In sizing thrust bearings, consider the following for each specified application:

- a. The shaft speed.
- b. The temperature of the bearing babbitt.
- c. The deflection of the bearing pad.
- d. The minimum oil film thickness.
- e. The feed rate, viscosity, and supply temperature of the oil.
- f. The design configuration of the bearing.
- g. The babbitt or other bearing surface material alloy and pad material.
- h. The turbulence of the oil film.

2.7.3.3 Thrust bearings shall be sized for continuous operation under the most adverse specified operating conditions. Calculations of the thrust forces shall include but shall not be limited to the following factors:

- a. Seal maximum design internal clearances and twice the maximum design internal clearances.
- b. Pressurized rotor diameter step changes.
- c. Stage maximum differential pressures.
- d. Specified extreme variations in inlet, interstage, and discharge pressures.
- e. The maximum thrust force that may be transmitted to the compressor thrust bearing by other equipment in the train (i.e., couplings, gears, or a motor without a thrust bearing).
- f. The maximum thrust force from the sleeve bearing type drive if the motor or generator is directly connected.

2.7.3.4 Thrust bearings shall be arranged to allow axial positioning of each rotor relative to the casing and setting the bearings' clearance.

2.7.3.5 Each pad within one side of the thrust bearing, shall be designed and manufactured with dimensional precision that will allow interchange or replacement of the individual pads.

Note: Instrumented and offset pivot designs do not allow interchange side to side.

- **2.7.3.6** When specified, or as approved by purchaser, directed lube may be used in lieu of flooded lube.

Note: Directed lube has advantages in power requirement, but has small passages with greater potential to plug.

- **2.7.3.7** When specified, thrust bearings pads shall be copper-alloy backed and shall have hardened steel inserts for support.

2.7.4 Bearing Housings

2.7.4.1 Rotor support system parts (bearings, bearing housings, bearing carriers, and bearing brackets) shall be separable from the casing, axially split, non-pressurized (vented to atmosphere), and furnished with plugged connections for dry air or inert gas purge to any atmospheric labyrinth seals. Axially split bearing housings shall have a metal-to-metal split joint whose halves are located by means of cylindrical dowels. The removal of the top half of the casing of an axially split machine or the head of a radially split unit shall not be required for replacement of these elements.

2.7.4.2 Shaft support structures bolted to casings shall be steel. However, if the compressor casing is manufactured from cast or ductile iron, the bearing housing support structures may be made from the same material.

2.8 SHAFT END SEALS

2.8.1 Shaft end seals and seal systems shall be in accordance with 2.8 of Chapter 1 of this standard.

Note 1: Typical cross sections of various shaft seals are given in Annex 1C.

Note 2: Equipment covered in this chapter may be available with any of the shaft end seal types covered in Chapter 1, or additional hybrid types may be available. The purchaser and vendor must mutually agree on the suitability of a particular seal for service.

- **2.8.2** Purchaser will specify the type of shaft end seal to be provided and all operating conditions including start-up, shut-down and settle out conditions.

Note: Axial compressors in process air service will generally be supplied with labyrinth shaft end seals. Process compressors may have any type of shaft end seal specified.

- **2.8.3** Shaft end seals and, when specified, shaft sleeves shall be accessible for inspection and for replacement without removing the top half of the casing for an axially split compressor or the heads of a radially split unit.

Note: This requirement may not be feasible for overhung designs.

2.9 GEARS

Internal gearing is not applicable for equipment covered in this chapter. For external gearing, see 3.1.8 of Chapter 1.

2.10 LUBRICATION AND SEALING SYSTEMS

- **2.10.1** The purchaser will specify whether the seal-oil and lube-oil systems are to be separate or combined. If separate systems are specified, the means of preventing interchange of oil between the two systems shall be described in the vendor's proposal.
- **2.10.2** Purchaser will specify type and properties of oil to be used. Unless otherwise specified, the lubricant shall be a hydrocarbon oil, of viscosity Grade 32, in accordance with ISO 8068.

2.11 NAMEPLATES AND ROTATION ARROWS

2.11.1 Nameplates and rotation arrows shall be in accordance with 2.11 of Chapter 1, and this section.

- **2.11.2** The following data shall be clearly stamped or engraved on the nameplate:

- Vendor's name.
- Serial number.
- Size, type and model.
- Rated capacity.
- Rated power.
- Lateral critical speeds up to and including the next lateral above maximum allowable speed (see 2.11.2.1).
- Purchaser item number or other reference.
- Maximum allowable working pressure.
- Minimum and maximum allowable working temperature.
- Minimum operating speed.
- Maximum continuous speed.
- Trip speed.
- Hydrostatic test pressure.

The purchaser will specify whether SI or U.S. Customary units are to be shown.

2.11.2.1 Lateral critical speeds exhibited during the running tests shall be stamped on the nameplate followed by the word "test." Lateral critical speeds predicted by calculation up to and including the critical speed above trip speed and not identifiable by test shall be stamped on the nameplate and noted as a calculated value.

2.11.3 Rotation arrows shall be cast-in or attached to each major item of rotating equipment at a readily visible location.

SECTION 3—ACCESSORIES

Accessories shall be in accordance with Section 3 of Chapter 1.

3.1 DRIVERS

Drivers shall be in conformance with 3.1 of Chapter 1.

3.2 COUPLINGS AND GUARDS

Couplings and guards shall be in conformance with 3.2 of Chapter 1.

3.3 MOUNTING PLATES

Mounting plates shall be in conformance with 3.3 of Chapter 1.

3.4 CONTROLS AND INSTRUMENTATION

3.4.1 Controls and instrumentation shall be in conformance with 3.4 of Chapter 1.

3.4.2 Control Systems

Control systems when supplied, shall be in accordance with 3.4.2 of Chapter 1, with the additions as noted below.

3.4.2.1 Axial compressors shall be supplied with a map of allowable operating range to permit the design of control logic to prevent operation in the region of choke and therefore avoid potentially dangerous blade stresses.

Note: Figures 2.1-1b and 2.1-1c show typical performance maps for axial compressors.

- **3.4.2.2** For constant-speed centrifugal compressors, the control signal shall actuate either a purchaser-furnished control valve in the compressor inlet piping or the adjustable inlet guide vanes furnished by the vendor as an integral part of the compressor, as specified. In the latter case, the vendor shall also furnish a guide-vane positioner compatible with the type of control signal specified by the purchaser. A direct-driven vane position indicator shall be provided that will be visible during operation of the machine.
- **3.4.2.3** For constant-speed axial compressors, the control signal shall the adjustable inlet guide vanes or and/or adjust-

able stator vanes furnished by the vendor as an integral part of the compressor, as specified. The vendor shall also furnish a vane positioner compatible with the type of control signal specified by the purchaser. A direct-driven vane position indicator shall be provided that will be visible during operation of the machine.

3.4.3 Instrument and Control Panels

Instrument and control panels, when supplied, shall be in accordance with 3.4.3 of Chapter 1.

3.4.4 Instrumentation

Instrumentation, when supplied, shall be in accordance with 3.4.4 of Chapter 1.

3.4.5 Alarms and Shutdowns

Alarms and shutdowns, when supplied, shall be in accordance with 3.4.5 of Chapter 1.

3.4.6 Electrical Systems

Electrical systems, when supplied, shall be in accordance with 3.4.6 of Chapter 1 of this standard.

3.4.7 Vibration, Position, and Bearing Temperature Detectors

3.4.7.1 Unless otherwise specified, radial shaft vibration and axial-position transducers and bearing temperature sensors shall be supplied, installed, and calibrated in accordance with API Std 670.

- **3.4.7.2** When specified, radial shaft vibration and axial-position monitors shall be supplied and calibrated in accordance with API Std 670.
- **3.4.7.3** Purchaser will specify type of temperature detector required per API Std 670.

- **3.4.7.4** When specified, a bearing temperature monitor shall be supplied and calibrated according to API Std 670.
- **3.4.7.5** When specified, casing vibration transducers shall be supplied, installed, and calibrated in accordance with API Std 670.
- **3.4.7.6** When specified, casing vibration monitors shall be supplied, installed and calibrated in accordance with API Std 670.

3.5 PIPING AND APPURTENANCES

3.5.1 General

Piping and appurtenances furnished shall be in accordance with 3.5 of Chapter 1 of this standard, with additions as follows.

3.5.1.1 When a baseplate has been specified, the vendor shall furnish all piping systems, including mounted appurtenances, located within its confines. The piping shall terminate with flanged connections at the edge of the baseplate. When soleplates have been specified, the extent of the piping system supplied by the vendor shall be defined by the purchaser. The purchaser will furnish only interconnecting piping between equipment groupings and off base facilities.

- **3.5.1.2** When specified, a liquid injection manifold shall be supplied. It shall include a throttle valve, an armored flow meter, a check valve, a pressure indicator, and a block valve for each injection point.

3.5.2 Process Piping

Process piping, if furnished, shall be in accordance with 2.4 of Chapter 1—API Std 614.

3.6 SPECIAL TOOLS

Special tools shall be in accordance with 3.6 of Chapter 1.

SECTION 4—INSPECTION, TESTING, AND PREPARATION FOR SHIPMENT

4.1 GENERAL

General requirements for inspection, testing and preparation for shipment shall be in accordance with 4.1 of Chapter 1. Also refer to Annex 2D for the inspector's checklist.

4.2 INSPECTION

Requirements for inspection shall be in accordance with 4.2 of Chapter 1.

4.3 TESTING

In addition to the requirements of Chapter 1, 4.3, the compressor(s) shall be tested in accordance with 4.3.1 and 4.3.2 of this chapter. Other tests that may be specified are described in 4.3.3.

Immediately upon completion of each witnessed mechanical or performance test, copies of the log data recorded during the test shall be given to the witnesses.

4.3.1 Mechanical Running Test

4.3.1.1 The requirements of 4.3.1.1.1 through 4.3.1.1.10 shall be met before the mechanical running test is performed.

4.3.1.1.1 The contract shaft seals and bearings shall be used in the machine for the mechanical running test, except that the atmospheric breakdown bushing(s) on oil seals may be replaced with a test bushing, if required.

Note: Low-pressure mechanical testing may require increased clearance or fewer elements for proper heat removal.

4.3.1.1.2 Oil viscosity, pressures, temperatures and filtration shall be within the range of operating values recommended in the vendor's operating instructions for the unit being tested. Oil flow rates to each oil seal and bearing housing shall be measured.

4.3.1.1.3 Oil system components downstream of the filters shall meet the cleanliness requirements of API Std 614 before any test is started.

4.3.1.1.4 All joints and connections shall be checked for tightness, and any leaks shall be corrected.

4.3.1.1.5 All warning, protective, and control devices used during the test shall be checked, and adjusted as required.

4.3.1.1.6 Facilities shall be installed to prevent the entrance of oil into the compressor during the mechanical running test. These facilities shall be in operation throughout the test.

4.3.1.1.7 Testing with the contract coupling(s) is preferred. If this is not practical, the mechanical running test shall be performed with coupling(s) or simulators, that have overhung moments within 10% of the contract coupling(s). The axial and circumferential location of the drive coupling hub on the shaft shall be marked or measured before starting the test.

4.3.1.1.8 All contract vibration probes, transducers, oscillator-demodulators, and accelerometers shall be used during the test.

4.3.1.1.9 Shop test facilities shall include the capability of continuously monitoring, displaying, recording and printing vibration displacement and phase, vibration spectra, Bode plots, and shaft orbits.

- **4.3.1.1.10** When specified, the user may furnish his own vibration equipment to record baseline readings.

4.3.1.1.11 The vibration characteristics determined using the instrumentation specified in 4.3.1.1.8 and 4.3.1.1.9 shall be the basis for acceptance or rejection of the machine (see 2.6.8.8 of Chapter 1).

4.3.1.2 At least 6 weeks prior to the first scheduled running test, the vendor shall submit to the purchaser, for his review and comment, detailed procedures for the mechanical run-

ning test and all specified running optional tests (see 4.3.3) including acceptance criteria for all monitored parameters.

4.3.1.2.1 The equipment shall be operated at speed increments of approximately 10% from zero to the maximum continuous speed and run at the maximum continuous speed until bearing metal temperatures and shaft vibrations have stabilized.

Note: Operating equipment at or near critical speeds should be avoided. For axial compressors, other speeds at or near blade resonant frequencies (see 2.5.6.1) should also be avoided.

4.3.1.2.2 The speed shall be increased to trip speed and the equipment shall be run for a minimum of 15 min.

4.3.1.2.3 The speed shall be reduced to the maximum continuous speed, and the equipment shall be run for 4 hours continuous operation.

4.3.1.3 During the mechanical running test, the requirements of 4.3.1.3.1 through 4.3.1.3.5 shall be met.

4.3.1.3.1 During the mechanical running test, the mechanical operation of all equipment being tested and the operation of the test instrumentation shall be satisfactory. The measured unfiltered vibration shall not exceed the limits of 2.6.8.8 of Chapter 1 and shall be recorded throughout the operating speed range. Any other test acceptance criteria shall be mutually agreed upon and stated in the test agenda.

4.3.1.3.2 While the equipment is operating at maximum continuous speed, or other speed required by the test agenda, vibration data shall be acquired to determine amplitudes at frequencies other than synchronous. This data shall cover a frequency range from 0.25 – 8 times the maximum continuous speed. If the amplitude of any discrete, nonsynchronous vibration exceeds 20% of the allowable vibration as defined in 2.6.8.8 of Chapter 1, the purchaser and the vendor shall mutually agree on requirements for any additional testing and on the equipment's acceptability.

4.3.1.3.3 The mechanical running test shall verify that lateral critical speeds conform to the requirements of Chapter 1, 2.6.2.

4.3.1.3.4 Shop verification of the unbalanced response analysis shall be performed in accordance with Chapter 1, 2.6.2.

4.3.1.3.5 When spare rotors are ordered to permit concurrent manufacture, each spare rotor shall also be given a mechanical running test in accordance with the requirements of this standard.

4.3.2 Assembled Compressor Gas Leakage Test

4.3.2.1 After the mechanical running test is completed, each completely assembled compressor casing intended for toxic, hazardous, or flammable service shall be tested as required in 4.3.2.2 and/or, when specified, 4.3.2.3.

Note: These tests are intended to verify the integrity of the casing joint. Some shaft seal designs are not gas tight. Therefore, leakage from these seals is acceptable.

4.3.2.2 The assembled compressor (including end seals) shall be pressurized, with an inert gas, to the maximum sealing pressure or the maximum seal design pressure, as agreed upon by the purchaser and the vendor; held at no less than this pressure for a minimum of 30 min. and subjected to a soap-bubble test, or alternate method, to check for gas leaks. The test shall be considered satisfactory when no casing or casing joint leaks are observed.

Note: Test gas mole weight should approximate or be less than contract gas mole weight. Helium for low mole weight contract gas, and nitrogen or refrigerant gas for high mole weight should be considered.

- **4.3.2.3** When specified, the assembled compressor (with or without end seals installed) shall be pressurized with an inert gas to the maximum specified discharge pressure, held at this pressure for a minimum of 30 min., and subjected to a soap-bubble test, or alternate method, to check for gas leaks. The test shall be considered satisfactory when no casing or casing joint leaks are observed.

Note: The requirements of 4.3.2.2 and 4.3.2.3 may necessitate two separate tests.

● 4.3.3 Optional Tests

The purchaser will specify whether any of the following shop tests shall be performed. Test details shall be mutually agreed upon by the purchaser and the vendor prior to the test.

4.3.3.1 Performance Test

4.3.3.1.1 The compressor shall be performance tested in accordance with ASME PTC 10-1997, ISO 5389 or other approved national standard. A minimum of five points, including surge and overload, shall be taken at normal speed. For variable-speed machines, additional points may be specified.

Note: Refer to the applicable test code for general instructions. ASME PTC 10-1997 may not apply to some low pressure ratio compressors. Refer to the scope, 1.2.2, of PTC 10-1997 for the selection of the appropriate test code to be used.

4.3.3.1.2 For variable speed machines, head and capacity shall have zero negative tolerance at the normal operating point (or other point as specified), and the power at this point shall not exceed 104% of the vendor predicted shaft power value. This tolerance shall be inclusive of all test tolerances. Surge shall comply with provisions of 2.1.1.1.

Note: Both of the performance test codes referred to have provision for calculating inaccuracy based on instrumentation and procedures.

These test inaccuracies are already included in the above tolerance and, therefore, are not to be further additive.

4.3.3.1.3 For variable-speed compressors, a speed other than the normal speed may be used, if necessary, to achieve the specified performance and performance tolerances, provided that this adjusted speed meets the criteria specified in Chapter 1, 2.6.

4.3.3.1.4 For constant-speed compressors, the capacity shall be as specified in 4.3.3.1.2. The head shall be within the range of 100% – 105% of the normal head. The horsepower, based on measured head at normal capacity, shall not exceed 107% of the value at the specified normal operating point. If the power required at this point exceeds 107%, excess head may be removed by trimming impellers at the purchaser's option.

4.3.3.1.5 The performance test shall be conducted using only one contract rotor, unless otherwise specified.

- **4.3.3.1.6** Compressors with intermediate specified process pressures shall have individual sectional head (pressure) tolerances as mutually agreed.

4.3.3.2 Complete Unit Test

Such components as compressors, gears, drivers, and auxiliaries that make up a complete unit shall be tested together during the mechanical running test. A separate auxiliary test may be performed with the purchaser's approval. The complete unit test may be performed in place of, or in addition to, separate tests of individual components as specified by the purchaser. When specified, torsional vibration measurements shall be made to verify the vendor's analysis.

4.3.3.3 Tandem Test

Compressor bodies arranged for tandem drive shall be tested as a unit during the mechanical running test, using the shop driver and oil systems as specified.

4.3.3.4 Gear Test

For units with external gears, the contract gear shall be tested with the machine(s) during the mechanical running test, as specified.

4.4 PREPARATION FOR SHIPMENT

Equipment shall be prepared for shipment in accordance with 4.4 of Chapter 1.

SECTION 5—VENDOR'S DATA

Vendor's data shall be in accordance with Section 5 of Chapter 1 of this document.

5.1 GENERAL

5.1.1 The information to be furnished by the vendor is specified in Annex 2B and Section 5 of Chapter 1. The vendor

shall complete and forward the VDDR form in Annex 2C, to the address or addresses noted on the inquiry or order. This form shall detail the schedule for transmission of drawings, curves, and data as agreed to at the time of the order, as well as the number and type of copies required by the purchaser.

**ANNEX 2A
TYPICAL DATA SHEETS**

Datasheets for axial and centrifugal compressors are presented in this section. These datasheets are also available in electronic form (Microsoft Excel Spreadsheets).

The beam type (impellers are located between the bearings) centrifugal compressor can be very flexible in configuration. Some of the more common seen configurations are in-line (single inlet and outlet), cooled (intermediate nozzles take out all of the flow to allow it to be cooled with an external cooler, and then re-introduced for another section of compression), and sideload (a portion of flow is introduced as an additional stream or taken out as an extraction).

This flexibility in configuration has required that the first page of the datasheet, which records the aerodynamic condi-

tions of the compressor, be commonly modified to meet the actual application.

In this edition, we have introduced two optional pages which can be used in lieu of the default page 1 for commonly seen configurations. Page 1a represents a two-section machine (as in an externally cooled unit with a single external cooling point), and page 1b represents a compressor with two sidestreams (SS), common for refrigeration applications.

There are of course many more available configurations, and the datasheets may still have to be modified to match the actual configuration; however, these two additional configurations will better serve as a model and will meet the requirements of more units than the simple in-line configuration shown on page 1.

CENTRIFUGAL AND AXIAL COMPRESSOR DATA SHEET (API 617—7TH Chapter 2) U.S. CUSTOMARY UNITS		JOB NO. _____ ITEM NO. _____ PURCHASE ORDER NO. _____ INQUIRY NO. _____ REVISION NO. _____ DATE _____ PAGE <u>1</u> OF <u>7</u> BY _____	
1 APPLICABLE TO: <input type="radio"/> PROPOSAL <input type="radio"/> PURCHASE <input type="radio"/> AS-BUILT 2 FOR _____ UNIT _____ 3 SITE _____ SERIAL NO. _____ 4 SERVICE _____ NO. REQUIRED _____ 5 MANUFACTURER _____ DRIVER TYPE (1-3.1.1) _____ 6 MODEL _____ DRIVER ITEM NO. _____ 7			
8 INFORMATION TO BE COMPLETED: <input type="radio"/> BY PURCHASER <input type="checkbox"/> BY MANUFACTURER <input checked="" type="checkbox"/> MUTUAL AGREEMENT (PRIOR TO PURCHASE)			
9 OPERATING CONDITIONS			
10 (ALL DATA ON PER UNIT BASIS)		10 NORMAL (1-2.1.1.2)	
		10 OTHER CONDITIONS (1-2.1.1.1)	
		11 A	11 B
		11 C	11 D
		11 E	
13 <input type="radio"/> GAS HANDLED (ALSO SEE PAGE _____)			
14 <input checked="" type="checkbox"/> GAS PROPERTIES (1-2.1.1.4)			
15 <input type="radio"/> MMSCFD/SCFM (14.7 PSIA & 60°F DRY)			
16 <input type="radio"/> WEIGHT FLOW, #/MIN (WET) (DRY)			
17 INLET CONDITIONS			
18 <input type="radio"/> PRESSURE (PSIA)			
19 <input type="radio"/> TEMPERATURE (°F)			
20 <input type="radio"/> RELATIVE HUMIDITY %			
21 <input type="radio"/> MOLECULAR WEIGHT			
22 <input type="checkbox"/> $C_p/C_v (K_1)$ OR (K_{AVG})			
23 <input type="checkbox"/> COMPRESSIBILITY (Z_1) OR (Z_{AVG})			
24 <input type="checkbox"/> INLET VOLUME, (CFM) (WET/DRY)			
25 DISCHARGE CONDITIONS			
26 <input type="radio"/> PRESSURE (PSIA)			
27 <input type="checkbox"/> TEMPERATURE (°F)			
28 <input type="checkbox"/> $C_p/C_v (K_2)$ OR (K_{AVG}) (NOTE 1)			
29 <input type="checkbox"/> COMPRESSIBILITY (Z_2) OR (Z_{AVG}) (NOTE 1)			
30 <input type="checkbox"/> GHP REQUIRED			
31 <input type="checkbox"/> TRAIN BHP REQUIRED			
32 <input type="checkbox"/> BHP REQUIRED AT DRIVER INCL. EXT. LOSSES (GEAR, ETC.)			
33 <input type="checkbox"/> SPEED (RPM)			
34 <input type="checkbox"/> TURNDOWN (%)			
35 <input type="checkbox"/> POLYTROPIC HEAD (FT-LB.)			
36 <input type="checkbox"/> POLYTROPIC EFFICIENCY (%)			
37 <input type="radio"/> CERTIFIED POINT			
38 <input type="checkbox"/> PERFORMANCE CURVE NUMBER			
39 PROCESS CONTROL (1-3.4.2.1)			
40 METHOD <input type="radio"/> SUCTION THROTTLING <input type="radio"/> VARIABLE INLET <input type="radio"/> SPEED VARIATION <input type="radio"/> DISCHARGE <input type="radio"/> COOLED BYPASS			
41 FROM _____ PSIA GUIDE VANES FROM _____ % BLOWOFF FROM _____			
42 TO _____ PSIA (2-3.4.2.2) TO _____ % TO _____ TO _____			
43 SIGNAL <input type="radio"/> SOURCE (1-3.4.2.1) _____			
44 TYPE <input type="radio"/> ELECTRONIC <input type="radio"/> PNEUMATIC <input type="radio"/> OTHER _____			
45 RANGE _____ MA _____ PSIG _____			
46			
47 <input type="radio"/> ANTI-SURGE SYSTEM (1-3.4.2.2)			
48 REMARKS: _____			
49			

	JOB NO. _____ ITEM NO. _____ PURCHASE ORDER NO. _____ INQUIRY NO. _____ REVISION NO. _____ DATE _____ PAGE <u>1b</u> OF <u>7</u> BY _____																																																																																																																																																																																																				
CENTRIFUGAL AND AXIAL COMPRESSOR DATA SHEET (API 617—7TH Chapter 2) U.S. CUSTOMARY UNITS																																																																																																																																																																																																					
1	APPLICABLE TO: <input type="radio"/> PROPOSAL <input type="radio"/> PURCHASE <input type="radio"/> AS-BUILT																																																																																																																																																																																																				
2	FOR _____ UNIT _____																																																																																																																																																																																																				
3	SITE _____ SERIAL NO. _____																																																																																																																																																																																																				
4	SERVICE _____ NO. REQUIRED _____																																																																																																																																																																																																				
5	MANUFACTURER _____ DRIVER TYPE (1-3.1.1) _____																																																																																																																																																																																																				
6	MODEL _____ DRIVER ITEM NO. _____																																																																																																																																																																																																				
7																																																																																																																																																																																																					
8	INFORMATION TO BE COMPLETED: <input type="radio"/> BY PURCHASER <input type="checkbox"/> BY MANUFACTURER <input type="checkbox"/> MUTUAL AGREEMENT (PRIOR TO PURCHASE)																																																																																																																																																																																																				
9	OPERATING CONDITIONS (SINGLE-COOLED CONFIGURATION)																																																																																																																																																																																																				
10	(ALL DATA ON PER UNIT BASIS)																																																																																																																																																																																																				
11	<table border="1" style="width: 100%; border-collapse: collapse;"> <thead> <tr> <th style="width: 40%;"></th> <th colspan="2" style="width: 20%;">NORMAL (1-2.1.1.2)</th> <th colspan="4" style="width: 40%;">OTHER CONDITIONS (1-2.1.1.1)</th> </tr> <tr> <th></th> <th style="width: 10%;">Section 1</th> <th style="width: 10%;">Section 2</th> <th style="width: 10%;">Section 1</th> <th style="width: 10%;">Section 2</th> <th style="width: 10%;">Section 1</th> <th style="width: 10%;">Section 2</th> </tr> </thead> <tbody> <tr><td>13</td><td></td><td></td><td></td><td></td><td></td><td></td></tr> <tr><td>14</td><td></td><td></td><td></td><td></td><td></td><td></td></tr> <tr><td>15</td><td></td><td></td><td></td><td></td><td></td><td></td></tr> <tr><td>16</td><td></td><td></td><td></td><td></td><td></td><td></td></tr> <tr><td>17</td><td></td><td></td><td></td><td></td><td></td><td></td></tr> <tr><td>18</td><td></td><td></td><td></td><td></td><td></td><td></td></tr> <tr><td>19</td><td></td><td></td><td></td><td></td><td></td><td></td></tr> <tr><td>20</td><td></td><td></td><td></td><td></td><td></td><td></td></tr> <tr><td>21</td><td></td><td></td><td></td><td></td><td></td><td></td></tr> <tr><td>22</td><td></td><td></td><td></td><td></td><td></td><td></td></tr> <tr><td>23</td><td></td><td></td><td></td><td></td><td></td><td></td></tr> <tr><td>24</td><td></td><td></td><td></td><td></td><td></td><td></td></tr> <tr><td>25</td><td></td><td></td><td></td><td></td><td></td><td></td></tr> <tr><td>26</td><td></td><td></td><td></td><td></td><td></td><td></td></tr> <tr><td>27</td><td></td><td></td><td></td><td></td><td></td><td></td></tr> <tr><td>28</td><td></td><td></td><td></td><td></td><td></td><td></td></tr> <tr><td>29</td><td></td><td></td><td></td><td></td><td></td><td></td></tr> <tr><td>30</td><td></td><td></td><td></td><td></td><td></td><td></td></tr> <tr><td>31</td><td></td><td></td><td></td><td></td><td></td><td></td></tr> <tr><td>32</td><td></td><td></td><td></td><td></td><td></td><td></td></tr> <tr><td>33</td><td></td><td></td><td></td><td></td><td></td><td></td></tr> <tr><td>34</td><td></td><td></td><td></td><td></td><td></td><td></td></tr> <tr><td>35</td><td></td><td></td><td></td><td></td><td></td><td></td></tr> <tr><td>36</td><td></td><td></td><td></td><td></td><td></td><td></td></tr> <tr><td>37</td><td></td><td></td><td></td><td></td><td></td><td></td></tr> <tr><td>38</td><td></td><td></td><td></td><td></td><td></td><td></td></tr> </tbody> </table>		NORMAL (1-2.1.1.2)		OTHER CONDITIONS (1-2.1.1.1)					Section 1	Section 2	Section 1	Section 2	Section 1	Section 2	13							14							15							16							17							18							19							20							21							22							23							24							25							26							27							28							29							30							31							32							33							34							35							36							37							38						
	NORMAL (1-2.1.1.2)		OTHER CONDITIONS (1-2.1.1.1)																																																																																																																																																																																																		
	Section 1	Section 2	Section 1	Section 2	Section 1	Section 2																																																																																																																																																																																															
13																																																																																																																																																																																																					
14																																																																																																																																																																																																					
15																																																																																																																																																																																																					
16																																																																																																																																																																																																					
17																																																																																																																																																																																																					
18																																																																																																																																																																																																					
19																																																																																																																																																																																																					
20																																																																																																																																																																																																					
21																																																																																																																																																																																																					
22																																																																																																																																																																																																					
23																																																																																																																																																																																																					
24																																																																																																																																																																																																					
25																																																																																																																																																																																																					
26																																																																																																																																																																																																					
27																																																																																																																																																																																																					
28																																																																																																																																																																																																					
29																																																																																																																																																																																																					
30																																																																																																																																																																																																					
31																																																																																																																																																																																																					
32																																																																																																																																																																																																					
33																																																																																																																																																																																																					
34																																																																																																																																																																																																					
35																																																																																																																																																																																																					
36																																																																																																																																																																																																					
37																																																																																																																																																																																																					
38																																																																																																																																																																																																					
12																																																																																																																																																																																																					
13	<input type="radio"/> GAS HANDLED (ALSO SEE PAGE ____)																																																																																																																																																																																																				
14	<input type="checkbox"/> GAS PROPERTIES (1-2.1.1.4)																																																																																																																																																																																																				
15	<input type="radio"/> MMSCFD/SCFM (14.7 PSIA & 60°F DRY)																																																																																																																																																																																																				
16	<input type="radio"/> WEIGHT FLOW, #/MIN (WET) (DRY)																																																																																																																																																																																																				
17	INLET CONDITIONS																																																																																																																																																																																																				
18	<input type="radio"/> PRESSURE (PSIA)																																																																																																																																																																																																				
19	<input type="radio"/> TEMPERATURE (°F)																																																																																																																																																																																																				
20	<input type="radio"/> RELATIVE HUMIDITY %																																																																																																																																																																																																				
21	<input type="radio"/> MOLECULAR WEIGHT																																																																																																																																																																																																				
22	<input type="checkbox"/> C_p/C_v (K_1) OR (K_{AVG})																																																																																																																																																																																																				
23	<input type="checkbox"/> COMPRESSIBILITY (Z_1) OR (Z_{AVG})																																																																																																																																																																																																				
24	<input type="checkbox"/> INLET VOLUME, (CFM) (WET/DRY)																																																																																																																																																																																																				
25	DISCHARGE CONDITIONS																																																																																																																																																																																																				
26	<input type="radio"/> PRESSURE (PSIA)																																																																																																																																																																																																				
27	<input type="checkbox"/> TEMPERATURE (°F)																																																																																																																																																																																																				
28	<input type="checkbox"/> C_p/C_v (K_2) OR (K_{AVG}) (NOTE 1)																																																																																																																																																																																																				
29	<input type="checkbox"/> COMPRESSIBILITY (Z_2) OR (Z_{AVG}) (NOTE 1)																																																																																																																																																																																																				
30	<input type="checkbox"/> GHP REQUIRED																																																																																																																																																																																																				
31	<input type="checkbox"/> TRAIN BHP REQUIRED																																																																																																																																																																																																				
32	<input type="checkbox"/> BHP REQUIRED AT DRIVER INCL. EXT. LOSSES (GEAR, ETC.)																																																																																																																																																																																																				
33	<input type="checkbox"/> SPEED (RPM)																																																																																																																																																																																																				
34	<input type="checkbox"/> TURNDOWN (%)																																																																																																																																																																																																				
35	<input type="checkbox"/> POLYTROPIC HEAD (FT-LB.)																																																																																																																																																																																																				
36	<input type="checkbox"/> POLYTROPIC EFFICIENCY (%)																																																																																																																																																																																																				
37	<input type="radio"/> CERTIFIED POINT																																																																																																																																																																																																				
38	<input type="checkbox"/> PERFORMANCE CURVE NUMBER																																																																																																																																																																																																				
39	PROCESS CONTROL (1-3.4.2.1)																																																																																																																																																																																																				
40	METHOD <input type="radio"/> SUCTION THROTTLING <input type="radio"/> VARIABLE INLET <input type="radio"/> SPEED VARIATION <input type="radio"/> DISCHARGE <input type="radio"/> COOLED BYPASS FROM _____ PSIA GUIDE VANES FROM _____ % BLOWOFF FROM _____ TO _____ PSIA (2-3.4.2.2) TO _____ % TO _____ TO _____																																																																																																																																																																																																				
41																																																																																																																																																																																																					
42																																																																																																																																																																																																					
43	SIGNAL <input type="radio"/> SOURCE (1-3.4.2.1) _____ TYPE <input type="radio"/> ELECTRONIC <input type="radio"/> PNEUMATIC <input type="radio"/> OTHER _____ RANGE _____ MA _____ PSIG																																																																																																																																																																																																				
44																																																																																																																																																																																																					
45																																																																																																																																																																																																					
46																																																																																																																																																																																																					
47	<input type="radio"/> ANTI-SURGE SYSTEM (1-3.4.2.2)																																																																																																																																																																																																				
48	REMARKS: _____																																																																																																																																																																																																				
49																																																																																																																																																																																																					

CENTRIFUGAL AND AXIAL COMPRESSOR DATA SHEET (API 617—7TH Chapter 2) U.S. CUSTOMARY UNITS		JOB NO. _____ ITEM NO. _____ REVISION NO. _____ DATE _____ PAGE <u>2</u> OF <u>7</u> BY _____							
OPERATING CONDITIONS (Continued) (1-2.1.1.1) (1-3.1.2) (1-3.1.3)									
2	GAS ANALYSIS:		NORMAL	A	B	C	D	E	REMARKS:
3	<input type="radio"/> MOL % <input type="radio"/>								
4									
5	AIR	28.966							
6	OXYGEN	32.000							
7	NITROGEN	28.016							
8	WATER VAPOR	18.016							
9	CARBON MONOXIDE	28.010							
10	CARBON DIOXIDE	44.010							
11	HYDROGEN SULFIDE	34.076							(1-2.2.1.6)
12	HYDROGEN	2.016							(1-2.2.1.9)
13	METHANE	16.042							
14	ETHYLENE	28.052							
15	ETHANE	30.068							
16	PROPYLENE	42.078							
17	PROPANE	44.094							
18	I-BUTANE	58.120							
19	n-BUTANE	58.120							
20	I-PENTANE	72.146							
21	n-PENTANE	72.146							
22	HEXANE PLUS								
23	CORROSIVE AGENTS								(1-2.2.1.3)
24									
25	TOTAL								
26	AVG. MOL. WT.								
27	LOCATION: (1-2.1.8)			NOISE SPECIFICATIONS: (1-2.1.9)					
28	<input type="radio"/> INDOOR <input type="radio"/> OUTDOOR <input type="radio"/> GRADE <input type="radio"/> HEATED <input type="radio"/> UNDER ROOF <input type="radio"/> MEZZANINE <input type="radio"/> UNHEATED <input type="radio"/> PARTIAL SIDES <input type="radio"/> _____			<input type="radio"/> APPLICABLE TO MACHINE: SEE SPECIFICATION _____ <input type="radio"/> APPLICABLE TO NEIGHBORHOOD: SEE SPECIFICATION _____					
29	<input type="radio"/> ELEC. AREA CLASSIFICATION (1-2.1.14) CL _____ GR _____ DIV _____			ACOUSTIC HOUSING: <input type="radio"/> YES <input type="radio"/> NO					
30	SITE DATA (1-2.1.8)			APPLICABLE SPECIFICATIONS:					
31	<input type="radio"/> ELEVATION _____ FT BAROMETER _____ PSIA <input type="radio"/> RANGE OF AMBIENT TEMPS:			API 617, 7TH CHAPTER 182					
32	DRY BULB WET BULB NORMAL °F _____ _____ MAXIMUM °F _____ _____ MINIMUM °F _____ _____ _____ °F _____ _____			<input type="radio"/> VENDOR HAVING UNIT RESPONSIBILITY (1-1.5.53) (1-1.8) (1-2.1.3) _____ <input type="radio"/> GOVERNING SPECIFICATION (IF DIFFERENT) _____					
33	UNUSUAL CONDITIONS:			PAINTING:					
34	<input type="radio"/> DUST <input type="radio"/> FUMES <input type="radio"/> OTHER (1-2.1.8) _____			<input type="radio"/> MANUFACTURER'S STD. <input type="radio"/> OTHER _____					
35	<input type="radio"/> COPPER AND COPPER ALLOYS PROHIBITED (1-2.2.1.14)			SHIPMENT: (4.4)					
36	COATING: (1-2.2.1.16)			<input type="radio"/> DOMESTIC <input type="radio"/> EXPORT <input type="radio"/> EXPORT BOXING REQD. <input type="radio"/> OUTDOOR STORAGE MORE THAN 6 MONTHS (1-4.4.1) _____ MO SPARE ROTOR ASSEMBLY PACKAGE (1-4.4.3.10) <input type="radio"/> HORIZONTAL STORAGE <input type="radio"/> VERTICAL STORAGE					
37	<input type="radio"/> ROTATING COMPONENTS _____ <input type="radio"/> STATIONARY COMPONENTS _____								
38	REMARKS: _____								
39	_____								
40	_____								
41	_____								
42	_____								
43	_____								
44	_____								
45	_____								
46	_____								
47	_____								
48	_____								
49	_____								

CENTRIFUGAL AND AXIAL COMPRESSOR DATA SHEET (API 617—7TH Chapter 2) U.S. CUSTOMARY UNITS	JOB NO. _____ ITEM NO. _____ REVISION NO. _____ DATE _____ PAGE <u>3</u> OF <u>7</u> BY _____
CONSTRUCTION FEATURES	
1 <input type="checkbox"/> SPEEDS: 2 MAX. CONT. _____ RPM TRIP _____ RPM 3 MAX. TIP SPEEDS: _____ FPS @ 100% SPEED 4 _____ FPS @ MAX. CONT. SPEED 5 6 <input type="checkbox"/> LATERAL CRITICAL SPEEDS (DAMPED) 7 FIRST CRITICAL _____ RPM _____ MODE 8 SECOND CRITICAL _____ RPM _____ MODE 9 THIRD CRITICAL _____ RPM _____ MODE 10 FOURTH CRITICAL _____ RPM _____ MODE 11 <input type="radio"/> LATERAL ANALYSIS ADDITIONAL REQUIREMENTS (1-2.6.2.14) 12 <input type="radio"/> TRAIN LATERAL ANALYSIS REQUIRED (1-2.6.2.6) 13 <input type="radio"/> TRAIN TORSIONAL ANALYSIS REQUIRED (1-2.6.7.1) 14 <input type="checkbox"/> TORSIONAL CRITICAL SPEEDS: 15 FIRST CRITICAL _____ RPM 16 SECOND CRITICAL _____ RPM 17 THIRD CRITICAL _____ RPM 18 FOURTH CRITICAL _____ RPM 19 <input type="radio"/> LIST OF TRAIN UNDESIRABLE SPEEDS (1-2.6.1.4) 20 <input type="radio"/> STABILITY ANALYSIS (1-2.6.5) 21 <input type="checkbox"/> VIBRATION: 22 ALLOWABLE TEST LEVEL _____ MILS 23 (PEAK TO PEAK) 24 NAMEPLATE (2-2.11.2) 25 <input type="radio"/> US CUSTOMARY <input type="radio"/> METRIC 26 <input type="checkbox"/> ROTATION, VIEWED FROM DRIVEN END <input type="radio"/> CW <input type="radio"/> CCW 27 <input type="radio"/> MATERIALS INSPECTION REQUIREMENTS (1-4.2.2.1) 28 <input type="radio"/> RADIOGRAPHY REQUIRED FOR _____ 29 <input type="radio"/> ULTRASONIC REQUIRED FOR _____ 30 <input type="radio"/> MAGNETIC PARTICLE REQUIRED FOR _____ 31 <input type="radio"/> LIQUID PENETRANT REQUIRED FOR _____ 32 <input type="radio"/> LOW TEMPERATURE (1-2.2.1.15.3) _____ 33 MIN. DESIGN METAL TEMPERATURE (°F) _____ 34 AT CONCURRENT PRESSURE (PSIG) _____ 35 <input type="radio"/> OTHER TRAIN COMPONENTS (1-2.2.1.15.2) _____ 36 <input type="checkbox"/> CASING: 37 MODEL _____ 38 CASING SPLIT _____ 39 MATERIAL _____ 40 THICKNESS (IN.) _____ CORR. ALLOW. (IN.) _____ 41 MAX. ALLOWABLE PRESS _____ PSIG 42 TEST PRESS (PSIG): HELIUM _____ HYDRO _____ 43 MAX. ALLOWABLE TEMPERATURE (°F) _____ 44 MAX OPER. TEMP. _____ °F MIN. OPER. TEMP. _____ °F 45 MAX CASING CAPACITY (ICFM) _____ 46 <input type="radio"/> SYSTEM RELIEF VALVE SET PT. (2-2.3.1.1) _____ PSIG 47 <input type="radio"/> Q.C. OF INACCESSIBLE WELDS (1-2.3.1.11.2) 48 <input type="checkbox"/> DIAPHRAGMS: 49 MATERIAL _____ 50 AXIALLY SPLIT <input type="checkbox"/> YES <input type="checkbox"/> NO (2-2.4.8)	<input type="radio"/> INTERMEDIATE MAIN PROCESS CONNECTIONS (2-2.4.5) DISCH. PRESSURE (PSIG): MAX _____ MIN _____ INLET PRESSURE (PSIG): MAX _____ MIN _____ <input type="checkbox"/> GUIDE VANES MATERIAL _____ NUMBER OF AXIAL BLADE ROWS _____ NUMBER OF ADJUSTIBLE ROWS _____ NO. VANES GUIDE VANE _____ <input type="checkbox"/> IMPELLERS: NO. _____ DIAMETERS _____ NO. VANES EA. IMPELLER _____ TYPE (OPEN, ENCLOSED, ETC.) _____ TYPE FABRICATION _____ MATERIAL _____ MIN. YIELD STRENGTH (PSI) _____ HARDNESS: (Rc) (BRINNEL) MAX _____ MIN _____ SMALLEST TIP INTERNAL WIDTH (IN.) _____ MAX. MACH. NO. @ IMPELLER EYE _____ MAX. IMPELLER HEAD @ 100% SPD (FT-LB.) _____ <input type="checkbox"/> SHAFT: <input type="radio"/> ONE PIECE <input type="radio"/> BUILT UP MATERIAL _____ DIA @ IMPELLERS (IN.) _____ DIA @ COUPLING (IN.) _____ SHAFT END: <input type="radio"/> TAPERED <input type="radio"/> CYLINDRICAL <input type="radio"/> SPLINED <input type="radio"/> INTEGRAL FLANGE MIN. YIELD STRENGTH (PSI) _____ SHAFT HARDNESS (BNH)(Rc) _____ MAX TORQUE CAPABILITY (FT-LB.) _____ <input type="checkbox"/> BALANCE PISTON: MATERIAL _____ AREA _____ (IN.) FIXATION METHOD _____ NORMAL CLEARANCE (IN.) _____ FLOW WITH NORMAL CLEARANCE (LB./MIN.) _____ FLOW WITH 2x NORMAL CLEARANCE (LB./MIN.) _____ <input type="radio"/> PRESS. CONN. BAL LINE DOWNSTREAM (2-2.5.4.3) <input type="checkbox"/> SHAFT SLEEVES: AT INTERSTG. CLOSE _____ MATL _____ CLEARANCE POINTS _____ AT SHAFT SEALS _____ MATL _____ <input type="radio"/> ACCESSIBLE (2-2.8.3) ROTOR <input type="radio"/> DISASSEMBLY AND REASSEMBLY (2-2.6.8.2.1.1) <input type="radio"/> AT SPEED BALANCING (1-2.6.8.3) <input type="radio"/> SEQUENTIAL LOW SPEED BAL. PREC. AT SPEED BAL. (1-2.6.8.6) <input type="radio"/> RESIDUAL BALANCE CHECK (1-2.6.8.7) <input type="checkbox"/> LABYRINTHS: INTERSTAGE TYPE _____ MATERIAL _____ BALANCE PISTON TYPE _____ MATERIAL _____

CENTRIFUGAL AND AXIAL COMPRESSOR DATA SHEET (API 617—7TH Chapter 2) U.S. CUSTOMARY UNITS		JOB NO. _____ ITEM NO. _____ REVISION NO. _____ DATE _____ PAGE <u>4</u> OF <u>7</u> BY _____									
CONSTRUCTION FEATURES (CONTINUED)											
1	SHAFT SEALS:	<input type="radio"/> BUFFER GAS CONTROL SYSTEM SCHEMATIC BY VENDOR									
2	<input type="radio"/> SEAL TYPE (1-2.8.1.3) _____	<input type="radio"/> PRESSURIZING GAS FOR SUBATMOSPHERIC SEALS (1-2.8.2.4)									
3	<input type="radio"/> SETTLING OUT PRESSURE (1-2.8.1.1) (PSIG) _____	<input type="radio"/> EDUCTOR <input type="radio"/> INJECTION (1-2.8.2.3)									
4	<input type="radio"/> MIN. SEALING PRESSURE (PSIG) _____	<input type="checkbox"/> SEAL MANUFACTURER _____									
5	<input type="radio"/> SUPPLEMENTAL DEVICE REQUIRED FOR CONTACT _____	<input type="checkbox"/> LEAKAGE TO PROCESS (GAL/DAY/SEAL) _____									
6	SEALS (1-2.8.3.4) TYPE _____	BUFFER GAS REQUIRED FOR:									
7	<input type="radio"/> TYPE BUFFER GAS (1-2.8.1.5) _____	<input type="checkbox"/> AIR RUN-IN <input type="checkbox"/> OTHER _____									
8	<input type="checkbox"/> PRESSURE (1-2.8.1.6) _____ (PSIG)	<input type="checkbox"/> FLOW (PER SEAL):									
9	<input type="checkbox"/> FLOWRATE _____ (LB./MIN.)	NORM: _____ LB./MIN. @ _____ PSI ΔP									
10	<input type="checkbox"/> FILTRATION _____	MAX: _____ LB./MIN. @ _____ PSI ΔP									
11	<input type="radio"/> BUFFER GAS SYSTEM REQUIRED (2-2.8.1.5)	<input type="checkbox"/> BEARING HOUSING CONSTRUCTION:									
12	<input type="radio"/> MANIFOLD (1-3.5.1.4)	TYPE (SEPARATE, INTEGRAL) _____ SPLIT _____									
13	<input type="radio"/> METHOD OF CONTROL (1-2.8.1.5)	MATERIAL _____									
AXIAL COMPRESSOR											
15	STAGE	1	2	3	4	5	6	7	8	9	
17	ROTOR										
18	<input type="checkbox"/> BLADE MATERIAL										
19	<input type="checkbox"/> BLADE ROOT TYPE										
20	<input type="checkbox"/> CORD WIDTH (IN.)										
21	<input type="checkbox"/> OUTER DIAMETER (IN.)										
22	<input type="checkbox"/> BLADE HEIGHT (IN.)										
23	<input type="checkbox"/> BLADE QUANTITY										
24	STATOR										
25	<input type="checkbox"/> BLADE MATERIAL										
26	<input type="checkbox"/> TYPE (MOVABLE, FIXED, ADJUSTABLE)										
27	<input type="checkbox"/> CORD WIDTH (IN.)										
28	<input type="checkbox"/> BLADE QUANTITY										
29											
30	STAGE	10	11	12	13	14	15	16	17	18	
32	ROTOR										
33	<input type="checkbox"/> BLADE MATERIAL										
34	<input type="checkbox"/> BLADE ROOT TYPE										
35	<input type="checkbox"/> CORD WIDTH (IN.)										
36	<input type="checkbox"/> OUTER DIAMETER (IN.)										
37	<input type="checkbox"/> BLADE HEIGHT (IN.)										
38	<input type="checkbox"/> BLADE QUANTITY										
39	STATOR										
40	<input type="checkbox"/> BLADE MATERIAL										
41	<input type="checkbox"/> TYPE (MOVABLE, FIXED, ADJUSTABLE)										
42	<input type="checkbox"/> CORD WIDTH (IN.)										
43	<input type="checkbox"/> BLADE QUANTITY										
44											
46	REMARKS: _____										
47	_____										
48	_____										
49	_____										

CENTRIFUGAL AND AXIAL COMPRESSOR DATA SHEET (API 617—7TH Chapter 2) U.S. CUSTOMARY UNITS	JOB NO. _____ ITEM NO. _____ REVISION NO. _____ DATE _____ PAGE <u>5</u> OF <u>7</u> BY _____
---	---

CONSTRUCTION FEATURES (CONTINUED)

2 BEARINGS AND BEARING HOUSINGS

3 MAGNETIC BEARINGS (2-2.7.1.1.2)

4 RADIAL	THRUST	NON-THRUST	THRUST	ACTIVE	INACTIVE
5 <input type="checkbox"/> TYPE			<input type="checkbox"/> TYPE		
6 <input type="checkbox"/> MANUFACTURER			<input type="checkbox"/> MANUFACTURER		
7 <input type="checkbox"/> LENGTH (IN.)			<input type="checkbox"/> UNIT LOADING (MAX PSI)		
8 <input type="checkbox"/> SHAFT DIA. (IN.)			<input type="checkbox"/> UNIT LOAD (ULT.) (PSI)		
9 <input type="checkbox"/> UNIT LOAD (ACT/ALLOW)			<input type="checkbox"/> AREA (IN.)		
10 <input type="checkbox"/> BASE MATERIAL			<input type="checkbox"/> NO. PADS		
11 <input type="checkbox"/> BABBIT THICKNESS (IN.)			<input type="checkbox"/> PIVOT: CENTER / OFFSET, %		
12 <input type="checkbox"/> NO. PADS			<input type="checkbox"/> PAD BASE MATL		
13 <input type="checkbox"/> LOAD: BTWN/ON PAD			<input type="radio"/> COPPER BACKED (2-2.7.3.7)		
14 <input type="checkbox"/> PIVOT: CTR/OFFSET, %			LUBRICATION: <input type="radio"/> FLOODED <input type="radio"/> DIRECTED (2-2.7.3.6)		
15 PAD MATERIAL <input type="radio"/> (2-2.7.2.2) <input type="radio"/> (2-2.7.2.3)			THRUST COLLAR: <input type="radio"/> INTEGRAL <input type="radio"/> REPLACEABLE		
16 <input type="checkbox"/> BEARING SPAN _____ IN.			MATERIAL _____		
			<input type="checkbox"/> SIZING CRITERIUM (2-2.7.3.3)		

18 BEARING TEMPERATURE DETECTORS (2-3.4.7)

19 <input type="radio"/> SEE ATTACHED API-670 DATASHEET 20 <input type="radio"/> THERMOCOUPLES TYPE _____ 21 <input type="radio"/> RESISTANCE TEMP DETECTORS 22 <input type="radio"/> RESISTANCE MAT'L _____ <input type="radio"/> _____ OHMS 23 <input type="checkbox"/> ALARM TEMPERATURE (°F) _____ 24 <input type="checkbox"/> SHUTDOWN TEMPERATURE (°F) _____ 25 <input type="radio"/> PROVISION FOR LOCAL DISCONNECT (1-2.7.4.6) 26 <input type="radio"/> LOCATION-JOURNAL BRG 27 NO. _____ EA PAD _____ EVERY OTH PAD _____ PER BRG 28 OTHER _____ 29 <input type="radio"/> LOCATION-THRUST BRG 30 NO. _____ EA PAD _____ EVERY OTH PAD _____ PER BRG 31 OTHER _____ 32 NO. (INACT) _____ EA PAD _____ EVERY OTH PAD _____ PER BRG 33 OTHER _____ 34 <input type="radio"/> LOCAL DISCONNECTION (1-2.7.4.6) 35 <input type="radio"/> MONITOR SUPPLIED BY (2-3.4.7.4) 36 <input type="radio"/> LOCATION _____ ENCLOSURE _____ 37 <input type="radio"/> MFR. _____ <input type="checkbox"/> MODEL _____ 38 <input type="checkbox"/> SCALE RGE _____ ALARM <input type="checkbox"/> SET @ °F _____ 39 <input type="radio"/> SHTDWN <input type="checkbox"/> SET @ _____ °F <input type="radio"/> TIME DELAY _____ SEC. 40	VIBRATION DETECTORS: <input type="radio"/> SEE ATTACHED API-670 DATA SHEET 19 <input type="radio"/> TYPE _____ <input type="checkbox"/> MODEL _____ 20 <input type="radio"/> MFR _____ 21 <input type="radio"/> NO. AT EA SHAFT BEARING _____ TOTAL NO. _____ 22 <input type="radio"/> OSCILLATOR-DETECTORS SUPPLIED BY 23 <input type="radio"/> MFR _____ <input type="checkbox"/> MODEL _____ MONITOR SUPPLIED BY (2-3.4.7.2) 24 <input type="radio"/> LOCATION _____ ENCLOSURE _____ 25 <input type="radio"/> MFR. _____ <input type="checkbox"/> MODEL _____ 26 <input type="checkbox"/> SCALE RGE _____ ALARM <input type="checkbox"/> SET @ _____ MILS 27 <input type="radio"/> SHTDWN: <input type="checkbox"/> SET @ _____ MILS <input type="radio"/> TIME DELAY _____ SEC.. 28 <input type="radio"/> CASING VIBRATION TRANSDUCERS (2-3.4.7.5) 29 <input type="radio"/> CASING VIBRATION MONITORS (2-3.4.7.6)
41 KEY PHASOR REQUIRED 42 <input type="radio"/> COMPRESSOR <input type="radio"/> GEAR H.S. <input type="radio"/> GEAR L.S.	AXIAL POSITION DETECTOR: <input type="radio"/> SEE ATTACH. API-670 DATA SHEET 30 <input type="radio"/> TYPE _____ <input type="checkbox"/> MODEL _____ 31 <input type="radio"/> MFR _____ <input type="radio"/> NO. REQUIRED _____ 32 <input type="radio"/> OSCILLATOR-DEMODULATOR SUPPLIED BY 33 <input type="radio"/> MFR _____ <input type="checkbox"/> MODEL _____ MONITOR SUPPLIED BY (2-3.4.7.2) 34 <input type="radio"/> LOCATION _____ ENCLOSURE _____ 35 <input type="radio"/> MFR. _____ <input type="checkbox"/> MODEL _____ 36 <input type="checkbox"/> SCALE RGE _____ <input type="radio"/> ALARM <input type="checkbox"/> SET @ _____ MILS 37 <input type="radio"/> SHTDWN: <input type="checkbox"/> SET @ _____ MILS <input type="radio"/> TIME DELAY _____ SEC.

43 CASING CONNECTIONS (1-2.3.2.2)

44 CONNECTION	<input type="checkbox"/> ANSI/ASME B16.1; B16.5; B16.42; B16.47 series A, B; ISO 7005-1, -2; OTHER	<input type="checkbox"/> FACING <input type="checkbox"/> BORE	<input type="radio"/> ORIENTATION	<input checked="" type="radio"/> FLANGED OR STUDDED (1-2.3.2.2.1)	<input type="radio"/> MATING FLG & GASKET BY VENDOR (1-2.3.2.2.7)	<input type="checkbox"/> GAS VELOCITY FT/SEC.
50 INLET						
51 DISCHARGE						
52						
53						
54						
55 <input type="radio"/> BOROSCOPIC INSPECTION PORTS (2-2.3.2.4)						

CENTRIFUGAL AND AXIAL COMPRESSOR DATA SHEET (API 617—7TH Chapter 2) U.S. CUSTOMARY UNITS		JOB NO. _____ ITEM NO. _____ REVISION NO. _____ DATE _____ PAGE <u>6</u> OF <u>7</u> BY _____					
1	<input type="checkbox"/> OTHER CONNECTIONS						
2	SERVICE:	NO.	SIZE	TYPE	NO.	SIZE	TYPE
3	LUBE-OIL INLET				PRESSURE		
4	LUBE-OIL OUTLET				TEMPERATURE		
5	SEAL-OIL INLET				SOLVENT INJECTION		
6	SEAL-OIL OUTLET				PURGE FOR:		
7	SEAL GAS INLET				BRG. HOUSING		
8	SEAL GAS OUTLET				BTWN BRG & SEAL		
9	CASING DRAINS				BTWN SEAL & GAS		
10	STAGE DRAINS						
11	<input type="radio"/> INDIVIDUAL STAGE DRAINS REQUIRED (1-2.3.2.1.7)						
12	<input type="radio"/> VALVED & BLINDED						
13	<input type="radio"/> VALVED & BLINDED & MANIFOLD						
14	LUBRICATION AND SEALING SYSTEMS (1-2.10) (1-3.5.1.2)						
15	<input type="radio"/> SEE ATTACHED API 614 DATASHEET						
16	<input type="radio"/> SEPARATE <input type="radio"/> COMBINED (2-2.10.1)						
17	<input type="radio"/> INTEGRAL OIL RESERVOIR (1-3.3.2.11)						
18	<input type="radio"/> OIL TYPE (2-2.10.2)						
19	ACCESSORIES						
20	COUPLING AND GUARDS (3.2)						
21	NOTE: SEE ROTATING ELEMENTS - SHAFT ENDS						
22	<input type="radio"/> SEE ATTACHED API-671 DATA SHEET <input type="radio"/> KEYLESS HYDRAULIC <input type="radio"/> KEYED <input type="radio"/> FLANGED <input type="radio"/> OTHER _____						
23	COUPLING FURNISHED BY _____						
24	MANUFACTURER _____ TYPE _____ MODEL _____						
25	COUPLING GUARD FURNISHED BY: _____						
26	TYPE: <input type="radio"/> FULLY ENCLOSED <input type="radio"/> SEMI-OPEN <input type="radio"/> OTHER						
27	COUPLING DETAILS						
28	<input type="checkbox"/> MAX O.D. _____ IN.			<input type="radio"/> PLUG AND RING GAUGES (1-3.2.5)			
29	<input type="checkbox"/> HUB WEIGHT _____ LB.			LUBRICATION REQUIREMENTS:			
30	<input type="checkbox"/> SPACER LENGTH _____ IN.			<input type="radio"/> NON-LUBE <input type="radio"/> CONT. OIL LUBE <input type="radio"/> OTHER _____			
31	<input type="checkbox"/> SPACER WEIGHT _____ LB.			QUANTITY PER HUB _____ GPM			
32							
33	MOUNTING PLATES (1-3.3)						
34	<input type="radio"/> BASEPLATES FURNISHED BY (1-3.3.2.1) _____						
35	<input type="radio"/> COMPRESSOR ONLY <input type="radio"/> DRIVER <input type="radio"/> GEAR						
36	<input type="radio"/> OTHER _____						
37	<input type="radio"/> NONSKID DECKING (1-3.3.2.4) <input type="radio"/> SLOPED DECK (1-3.3.2.4.1)						
38	<input type="checkbox"/> LEVELING PADS OR TARGETS (1-3.3.2.6)						
39	<input type="checkbox"/> COLUMN MOUNTING (1-3.3.2.5)						
40	<input type="radio"/> SUB-SOLE PLATES REQUIRED (1-3.3.2.10)						
41	<input type="checkbox"/> STAINLESS STEEL SHIM THICKNESS _____ IN.						
42	<input type="radio"/> MACHINED MOUNTING PADS REQUIRED (1-3.3.2.9)						
43							
44							
45							
46							
47							
48							
49							

.....

ANNEX 2B
CENTRIFUGAL AND AXIAL COMPRESSOR VENDOR
DRAWING AND DATA REQUIREMENTS

**API STANDARD 617
CHAPTER 2 ANNEX B
VENDOR DRAWING AND
DATA REQUIREMENTS**

JOB NO. _____ ITEM NO. _____
 PURCHASE ORDER NO. _____ DATE _____
 REQUISITION NO. _____ DATE _____
 INQUIRY NO. _____ DATE _____
 PAGE _____ OF _____ BY _____
 REVISION _____
 UNIT _____
 NO. REQUIRED _____

FOR _____
 SITE _____
 SERVICE _____

Proposal^a Bidder shall furnish _____ copies of data for all items indicated by an X.

Review^b Vendor shall furnish _____ copies and _____ transparencies of drawings and data indicated.

Final^c Vendor shall furnish _____ copies and _____ transparencies of drawings and data indicated.
 Vendor shall furnish _____ operating and maintenance manuals.

**DISTRIBUTION
RECORD**

Final—Received from vendor _____
 Final—Due from vendor^c _____
 Review—Returned to vendor _____
 Review—Received from vendor _____
 Review—Due from vendor^c _____

DESCRIPTION

		<ol style="list-style-type: none"> 1. Certified dimensional outline drawing and list of connections 2. Cross-sectional drawings and part numbers 3. Rotor assembly drawings and part numbers 4. Thrust-bearing assembly drawings and part numbers 5. Journal-bearing assembly drawings and bill of materials 6. Coupling assembly drawings and bill of materials 7. Lube-oil schematic and bill of materials 8. Lube-oil arrangement drawing and list of connections 9. Lube-oil component drawings and data 10. Seal system schematic and bill of material 11. Seal system arrangement drawing and list of connections 12. Seal system component drawings and data 13. Seal assembly drawing and part numbers 14. Electrical and instrumentation schematics and bill of materials 15. Electrical and instrumentation arrangement of drawing and list of connections 16. Buffer gas system schematic and bill of material 17. Buffer gas system arrangement drawing and list of connections 18. Buffer gas system component drawing and data 19. Data sheets (proposal/as-built) 20. Predicted noise sound level (proposal) 21. Metallurgy of major components (in proposal) 22. Lateral analysis report 23. Torsional analysis report 24. Vibration analysis report 					

^a Proposal drawings and data do not have to be certified or as-built.

^b Purchaser will indicate in this column the desired time frame for submission of materials, using the nomenclature given at the end of this form.

^c Bidder shall complete this column to reflect his actual distribution schedule and include this form with his proposal.

^d These items are normally provided only in instruction manuals.

^e If furnished by the vendor.

^f If specified.

**API STANDARD 617
CHAPTER 2 ANNEX B
VENDOR DRAWING AND
DATA REQUIREMENTS**

JOB NO. _____ ITEM NO. _____
PAGE _____ OF _____ BY _____
DATE _____ REVISION _____

Proposal^a Bidder shall furnish _____ copies of data for all items indicated by an X.

Review^b Vendor shall furnish _____ copies and _____ transparencies of drawings and data indicated.

Final^c Vendor shall furnish _____ copies and _____ transparencies of drawings and data indicated.
Vendor shall furnish _____ operating and maintenance manuals.

**DISTRIBUTION
RECORD**

Final—Received from vendor
Final—Due from vendor^c
Review—Returned to vendor
Review—Received from vendor
Review—Due from vendor^c

DESCRIPTION

No.	DESCRIPTION	Final ^c	Review ^b	Proposal ^a
25.	Performance curves for each compressor section (proposal/as-built)			
26.	Impeller overspeed test report			
27.	Mechanical running test report			
28.	Coupling selection and rating			
29.	List of recommended spare parts			
30.	List of special tools			
31.	Preparation for storage at job site before installation			
32.	Weather protection and winterization required at job site			
33.	Tabulation of all utilities			
34.	List of similar machines			
35.	Operating restrictions to protect equipment during start-up operation and shutdown			
36.	List of components requiring purchaser's approval			
37.	Summary of materials and hardness of materials exposed to H ₂ S			
38.	Seal leakage rates			
39.	Interstage cooler system data			
40.	Drawings, details and description of instrumentation and controls			
41.	Minimum length of straight pipe required at machine inlet or side inlets			
42.	Maximum and minimum allowable seal pressure for each compressor			
43.	Statement of manufacturer's testing capabilities			
44.	Performance test data and curves			
45.	Back-to-back impeller machine vendor to provide thrust bearing loads versus differential pressure curve			
46.	Balance piston leakage rates			
47.	When specified, vendor shall supply curves of balance piston line differential pressure versus thrust load			
48.	Production/delivery schedule			
49.	Testing procedures			
50.	Progress reports			
51.	Installation manual			
52.	Operating and maintenance manual			
53.	Technical data manual			

^aProposal drawings and data do not have to be certified or as-built.

^bPurchaser will indicate in this column the desired time frame for submission of materials, using the nomenclature given at the end of this form.

^cBidder shall complete this column to reflect his actual distribution schedule and shall include this form with his proposal.

^dThese items are normally provided only in instruction manuals.

^eIf furnished by the vendor.

^fIf specified.

**API STANDARD 617
CHAPTER 2 ANNEX B
VENDOR DRAWING AND
DATA REQUIREMENTS**

JOB NO. _____ ITEM NO. _____
PAGE _____ OF _____ BY _____
DATE _____ REVISION _____

Notes:

1. Where necessary to meet the scheduled shipping date, the vendor shall proceed with manufacture upon receipt of the order and without awaiting the purchaser's approval of drawings.
2. The vendor shall send all drawings and data to the following:

-
3. All drawings and data shall show project, purchase order, and item numbers as well as plant location and unit. One set of the drawings and instructions necessary for field installation, in addition to the copies specified above, shall be forwarded with shipment.
 4. See the descriptions of required items that follow.
 5. All of the information indicated on the distribution schedule shall be received before final payment is made.
 6. If typical drawings, schematics, bills of material are used for proposals, they shall be marked-up to show the expected weight and dimensions to reflect the actual equipment and scope proposed.

Nomenclature:

- S—number of weeks before shipment.
- F—number of weeks after firm order.
- D—number of weeks after receipt of approved drawings.

Vendor _____

Date _____ Vendor Reference _____

Signature _____

(Signature acknowledges receipt of all instructions)

**API STANDARD 617
CHAPTER 2 ANNEX B
VENDOR DRAWING AND
DATA REQUIREMENTS**

JOB NO. _____ ITEM NO. _____
PAGE _____ OF _____ BY _____
DATE _____ REVISION _____

DESCRIPTION

1. Certified dimensional outline drawing and list of connections, including the following:
 - a. The size, rating and location of all customer connections.
 - b. Approximate overall and handling weights.
 - c. Overall dimensions and maintenance and dismantling clearances.
 - d. Shaft centering height.
 - e. Dimensions of base plate (if furnished) for train or skid mounted package, complete with diameters, number and locations of bolt holes and thicknesses of sections through which the bolts must pass.
 - f. Grounding details.
 - g. Forces and moments allowed for suction and discharge nozzles.
 - h. Center of gravity and lifting points.
 - i. Shaft end separation and alignment data.
 - j. Direction of rotation.
 - k. Winterization, tropicalization and/or noise attenuation details, when required.
 - l. Sketches to show lifting of assembled machine and major components and auxiliaries.
2. Cross-sectional drawings and part numbers of major equipment.
3. Rotor assembly drawings and part numbers.
4. Thrust-bearing assembly drawings and part numbers.
5. Journal-bearing assembly drawings and bill of materials.
6. Coupling assembly drawing and bill of materials.
7. Lube-oil schematic and bill of material including the following:
 - a. Oil flows, temperatures and pressure at each point.
 - b. Control alarm shutdown settings for pressure and temperature.
 - c. Total heat loads.
 - d. Utility requirements including electrical, water, air and steam.
 - e. Pipe, valve and orifice sizes.
 - f. Instrumentation, safety devices, control schemes and wiring diagrams.
8. Lube-oil arrangement drawing and list of connections.
9. Lube-oil component drawings and data, including the following:
 - a. Pumps and drivers.
 - b. Coolers, filter and reservoir.
 - c. Instrumentation.
10. Seal system schematic and bill of material, including the following:
 - a. Flows oil or gas, temperatures and pressures at each point.
 - b. Control, alarm and shutdown settings for pressure and temperatures.
 - c. Total heat load for coolers, if required.
 - d. Utility requirements including electrical, water, air and steam.
 - e. Pipe, valve and orifice sizes.
 - f. Instrumentation, safety devices, control schemes and wiring diagrams.
 - g. Filtration requirements.
 - h. Height of overhead tank above centerline of machine.
11. Seal system arrangement drawing and list of connections.

**API STANDARD 617
CHAPTER 2 ANNEX B
VENDOR DRAWING AND
DATA REQUIREMENTS**

JOB NO. _____ ITEM NO. _____
PAGE _____ OF _____ BY _____
DATE _____ REVISION _____

12. Seal system components drawing and data, including the following:
 - a. Pumps and drivers.
 - b. Coolers, filter and reservoirs.
 - c. Instrumentation.
13. Seal assembly drawing and part numbers.
14. Electrical and instrumentation arrangement drawing and list of connections.
 - a. Vibration warning and shutdown limits.
 - b. Bearing temperature warning and shutdown limits.
 - c. Lube-oil temperature warning and shutdown limits.
 - d. Lube-oil pressure warning and shutdown limits.
 - e. Lube-oil level warning and shutdown limits.
 - f. Machine discharge pressure and temperature warning and shutdown limits.
 - g. Seal, pressure, temperature, flow warning and shutdown limits.
15. Electrical and instrumentation arrangement drawing and list of connections.
16. Buffer gas system schematic and bill of material.
17. Buffer gas system schematic and bill of material.
18. Buffer gas system component drawings and data, including the following:
 - a. Control devices.
 - b. Pressure and filtration requirements.
19. Data sheets provided with proposal as-built.
20. Predicted noise level, sound pressure, and sound power level.
21. Metallurgy of major components identified with ASTM, AISI, ASME, or SAE numbers stated in proposal.
22. Lateral analysis report when specified shall also include a stability analysis.
23. Torsional analysis report.
24. Vibration analysis conducted on machines that require disassembly after balancing to allow machine assembly. The vendor shall also provide historic unbalance data for the machine size and type.
25. Performance data and curves, sufficient performance data to enable the purchaser to properly design a control system and surge prevention.
26. Dimensions taken from each impeller before and after overspeed testing shall be submitted for review.
27. Mechanical running test report to include the following:
 - a. Unfiltered vibration.
 - b. Plots showing synchronous vibration and phase angle, filtered and unfiltered.
 - c. When specified data shall be furnished in polar form.
 - d. When specified tape recordings shall be made of all real time vibration data.
 - e. Electrical and mechanical runout at each probe.

Immediately upon completion of each witnessed mechanical or performance test, copies of the log and data recorded during the test shall be given to the witnesses.
28. Coupling selection and rating.
29. List of spare parts recommended for start-up and normal maintenance purposes.
30. List of the special tools furnished for maintenance.
31. The vendor shall provide the purchaser with instructions necessary to preserve the integrity of the storage preparation after the equipment arrives at the job site and before start-up.
32. A description of any special weather protection required for start-up, operation and period of idleness under the site conditions specified on the data sheets.

**API STANDARD 617
CHAPTER 2 ANNEX B
VENDOR DRAWING AND
DATA REQUIREMENTS**

JOB NO. _____ ITEM NO. _____
PAGE _____ OF _____ BY _____
DATE _____ REVISION _____

33. A complete list of utility requirements: quantity, filtration and supply pressure of the following:
 - a. Steam.
 - b. Water.
 - c. Electricity.
 - d. Air.
 - e. Gas.
 - f. Lube oil and seal oil (quantity and supply pressure).
 - g. Heat loads.
 - h. Power ratings and operating power requirements for auxiliary drivers.
34. A list of machines similar to the proposed machines that have been installed and operating under conditions analogous to those specified in the inquiry.
35. Any start-up, shutdown or operating restrictions required to protect the integrity of the equipment, including any unacceptable speeds due to natural frequencies.
36. A list of any components that can be construed as being of alternative design, requiring purchaser's acceptance.
37. A summary of the materials of construction for the compressor, including hardness for materials exposed to H₂S.
38. The maximum seal gas rates (injection or eduction) and rated or expected inner seal-oil leakage rates, if applicable. When self-acting dry gas seals are supplied, expected seal gas consumption, minimum seal gas supply flow and primary vent flow should be given at maximum sealing pressure and at conditions over the operating envelope of the machine.
39. When interstage coolers are furnished, the vendor shall provide the following:
 - a. Drawing showing cooling system details.
 - b. Data for purchasers heat and material balances.
 - c. Details of provisions for separating and withdrawing condensate.
 - d. Vendor's recommendations regarding provision for support and piping expansion.
40. Drawings, details and descriptions of the operations of instrumentation and controls as well as the makes, materials and type of auxiliary equipment. The vendor shall also include a complete description of the alarm and shutdown facilities to be provided.
41. The minimum length of straight pipe required for proper flow characteristics at the inlet and at any side inlet connection.
42. Maximum and minimum allowable seal pressure for each compressor.
43. A statement of the manufacturers capability regarding testing (including performance testing) of the compressor and any other specified items on the train. Details of each optional test specified shall be included.
44. Performance curves shall be submitted for each section (between purchasers process nozzles) of each casing as well as an overall curve for the train. All curves submitted prior to complete performance testing shall be marked "predicted." Any set of curves resulting from a test shall be marked "tested."

If a performance test is specified, the vendor shall provide test data and curves when the test has been completed. The surge points shall be shown on the performance curves.
45. For compressors that have a back-to-back impeller arrangement, the vendor shall furnish a curve showing the expected loading on the active or inactive side of the thrust bearing versus any combination of differential pressures across the low pressure and high pressure sections of the casing.
46. The vendor shall supply balance piston leakage based on design clearances and twice design clearances for the rated conditions.

**API STANDARD 617
CHAPTER 2 ANNEX B
VENDOR DRAWING AND
DATA REQUIREMENTS**

JOB NO. _____ ITEM NO. _____
PAGE _____ OF _____ BY _____
DATE _____ REVISION _____

47. When specified, the vendor shall supply curves of balance piston line differential pressure versus thrust load.
48. The vendor shall provide production and delivery schedules.
49. The vendor shall submit detailed procedures including acceptance criteria for the mechanical running test and all optional tests, at least 6 weeks prior to the first running test.
50. The vendor shall submit progress reports.
51. All information required for the proper installation of the equipment shall be compiled in a manual that must be issued no later than the time of final certified drawings.
52. A manual containing all required operating and maintenance instructions shall be supplied not later than 2 weeks after all specified test shall have been successfully completed.
53. The vendor shall provide a “technical data manual within 30 days of completion” of shop testing including the following:
 - a. Necessary certification of materials.
 - b. Purchase specification for all items on the bill of materials.
 - c. Test data to verify requirements of specifications have been met.
 - d. Heat treat records.
 - e. Results of quality test and inspections.
 - f. Mechanical running test data log.
 - g. Final assembly maintenance and running clearances.

The vendor is also required to keep this data available for examination by the purchaser upon request, for at least 5 years.

ANNEX 2C
CENTRIFUGAL AND AXIAL COMPRESSOR NOMENCLATURE

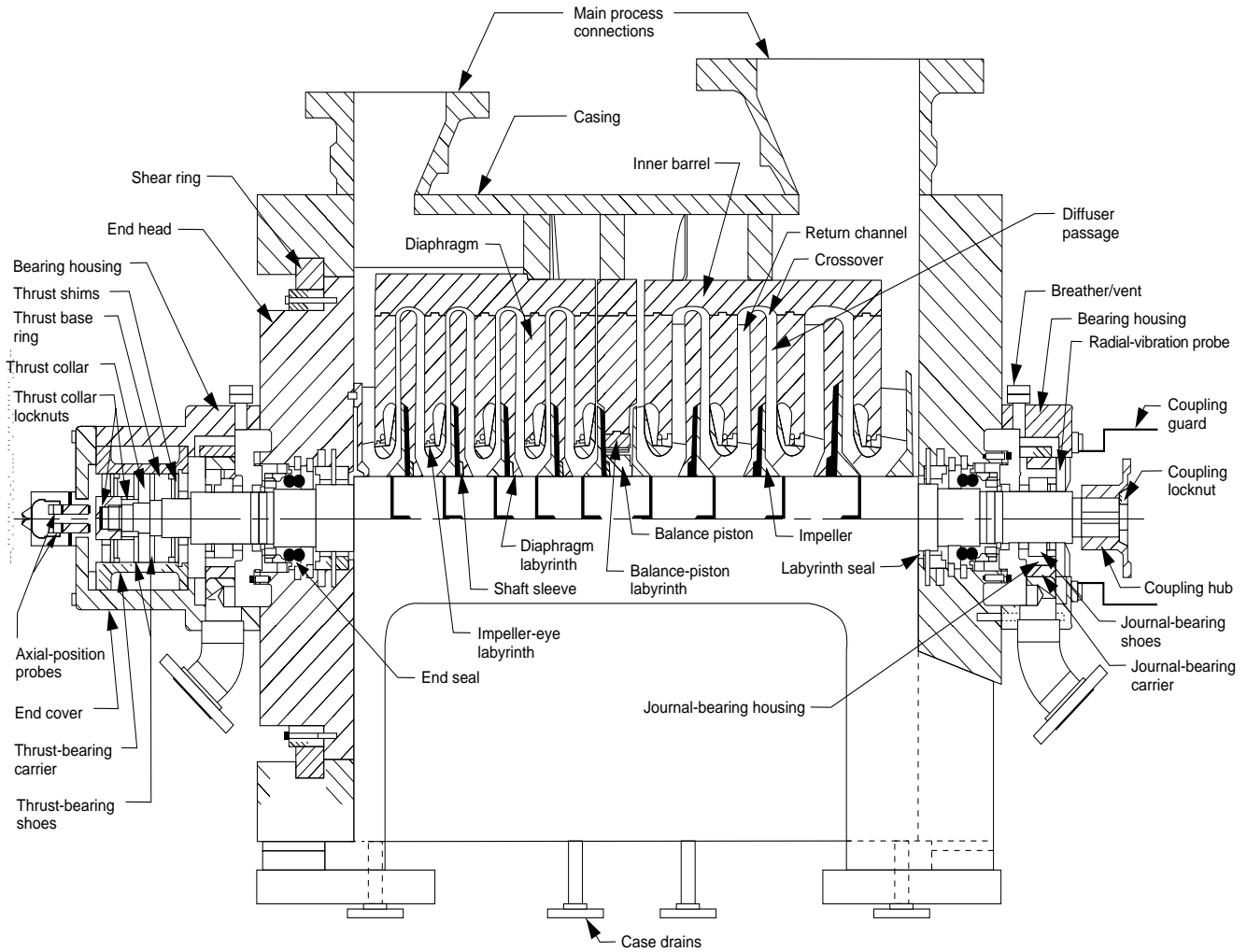

Figure 2.C-1—Typical Centrifugal Compressor Showing Nomenclature of Key Parts

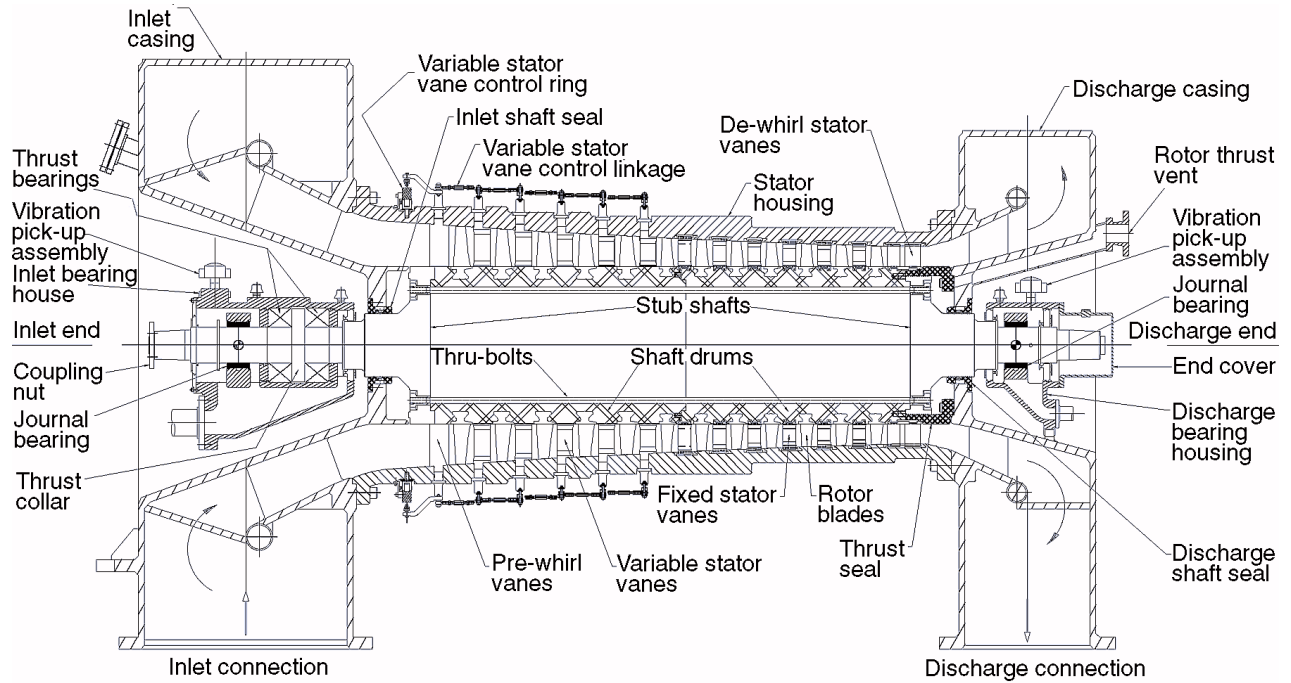

Figure 2.C-2—Typical Axial Compressor Showing Nomenclature of Key Parts

**ANNEX 2D
INSPECTOR'S CHECK LIST**

Item	Standard 617		Reviewed	Observed	Witnessed	Inspected By	Status
	Par	Ch					
GENERAL							
Contract Review—Testing and Inspections Listed in Proposal	2.2.1.4	1					
General Test Requirements	4.1.1 4.1.3 4.1.4 4.1.4.1 4.1.6 4.1.7 4.2.1 4.2.1.2	1 1 1 1 1 1 1 1					
Cleanliness	4.2.1.3 4.2.1.4	1 1					
Hardness	4.2.1.5	1					
Case Support Mounting Surfaces	2.3.3.1	2					
Nameplate	2.11.1 2.11.2 2.11.2.1	1 2 2					
Rotation Arrows	2.11.3	2					
MATERIAL INSPECTIONS							
Material Inspections	4.2.2.1	1					
Castings	2.2.2.1	1					
Low Temperature Impact	2.2.1.15.5	1					
Forgings	2.2.3.2	1					
Weldings	2.2.4.1	1					
Pressure-containing Casings	2.3.1	1					
Material Inspection of Pressure-containing Parts	2.3.1.12	1					
ROTATING ELEMENT							
Impellers	2.5.10.4 2.5.10.5 2.5.10.6 4.3.3.1	1 1 1 1					
Overspeed	2.5.10.7 4.3.3.1	1 1					
Balance	2.6.8 2.6.8.8 Annex B	1 1					
Run-out	2.6.8.9 2.6.8.10	1 1					
ACCESSORIES							
Shaft End Seals	4.3.5 Annex D	1					
Lubrication and Sealing Systems	2.10.3 API Std 614	1					
Drivers	3.1	1					
Steam Turbine	3.1.4 API Std 612	1					
Motor	3.1.5 API Std 541	1					
Gas Turbine	3.1.7 API Std 616	1					
Separate Gear Units	3.1.8 API Std 613	1					
Coupling and Guard	3.2 API Std 671	1					

Item	Standard 617		Reviewed	Observed	Witnessed	Inspected By	Status
	Par	Ch					
Instrumentation	3.4.3 3.4.4 API Std 614 API Std 670	1 1					
Alarms and Shutdowns	3.4.5 API Std 614	1					
Electrical Systems	3.4.6 API Std 614 2.1.14	1 1					
Piping	3.5.1 API Std 614	1					
Special Tools	3.6.1 3.6.2	1 1					
HYDROSTATIC TEST							
Hydrostatic Test	4.3.2.1 4.3.2.2 4.3.2.3	1 1 1					
OVERSPEED TEST							
Impeller Overspeed Test	4.3.3.1	1					
MECHANICAL RUNNING TEST							
Unbalance Response Verification	2.6.3.1	1					
Vibration Record	2.6.3.1.1 4.3.6.1.1 4.3.6.1.2 4.3.6.1.3	1 1 1 1					
Contract Shaft Seals Used in Test	4.3.6.1.4 4.3.1.1.1	1 2					
Oil Flow Rates P. & T.	4.3.1.1.2	2					
Oil System Clean	4.3.1.1.3 API Std 614	2					
Warning Protective Control Devices Checked	4.3.1.1.5	2					
Connections Check for Leaks	4.3.1.1.4	2					
Test Coupling Used	4.3.1.1.7	2					
Vibration Levels	4.3.1.1.8 4.2.1.1.9 4.3.1.1.11	2 2 2					
Test Speeds Performed	4.3.1.2.1	2					
Test Run at Trip Speed	4.3.1.2.2	2					
4-hour Test Run	4.3.1.2.3 4.3.1.3.1 4.3.1.3.2 4.3.1.3.3 4.3.1.3.4 4.3.1.3.5	2 2 2 2 2 2					
Seal Flow Data	4.3.1.1.2	2					
Lube and Seal Oil Flows Varied	4.3.6.1.5	1					
Lateral Critical Speed Verified	4.3.1.3.3	2					
Unbalance Response Analysis Verified	4.3.1.3.4	2					
Spare Rotor Tested	4.3.1.3.5	2					
Bearing Inspected After Test	4.3.6.2.1	1					
Seals Inspected After Test	4.3.6.2.2	1					
Assembled Compressor Gas Leak	4.3.2	2					

Item	Standard 617		Reviewed	Observed	Witnessed	Inspected By	Status
	Par	Ch					
OPTIONAL TESTING	4.3.3	2					
Performance Test	4.3.3.1	2					
	4.3.3.1.1	2					
	4.3.3.1.2	2					
	4.3.3.1.3	2					
	4.3.3.1.4	2					
	4.3.3.1.5	2					
Complete Unit Test	4.3.3.1.6	2					
Complete Unit Test	4.3.3.2	2					
Tandem Test	4.3.3.3	2					
Gear Test	4.3.3.4	2					
Helium Test	4.3.8.2	1					
Sound-level Test	4.3.8.3	1					
Auxiliary Equipment Test	4.3.8.4	1					
Post-test Inspection of Compressor Internal	4.3.8.5	1					
Full-pressure/Full-load/Full-speed Test	4.3.8.6	1					
Post-test Inspection of Hydraulic Coupling Fit	4.3.8.7	1					
Spare Parts Test	4.3.8.8	1					
PREPARATION FOR SHIPMENT							
Equipment Prepared	4.4.1	1					
	4.4.2	1					
Paint	4.4.3.1	1					
Exterior Machined Surfaces Coated	4.4.3.2	1					
Bearing Housings, Oil Systems, Auxiliary Equipment and Piping Preserved	4.4.3.4	1					
Openings Covered and Protected	4.4.3.5	1					
	4.4.3.6	1					
	4.4.3.7	1					
Lifting Points Identified	4.4.3.8	1					
Equipment Identified, Tagged, Packing List	4.4.3.9	1					
Spare Rotor Prepared for Storage	4.4.3.10	1					
Exposed Shafts, etc. Prepared for Shipment	4.4.3.12	1					
Auxiliary Piping Connections Tagged or Stamped	4.4.4	1					
	4.4.5	1					
Installation, Instructions Shipped with Equipment	4.4.6	1					

ANNEX 2E FORCES AND MOMENTS

E.1 General

E.1.1 The April 1988, November 1979, and October 1973 issues of this standard referred nozzle forces and moments calculations to appropriate NEMA documents with the stipulation that the constants in the equations be multiplied by 1.85. Experience has shown that there has not been a uniform interpretation of “1.85 times NEMA.” Therefore, the equations have been adapted to compressors by identifying all the constants and clarifying that the equivalent of the exhaust nozzle in the NEMA calculation is the largest compressor nozzle. This is usually, but not necessarily, the inlet nozzle.

Modified to include other machinery that is less tolerant to the current formulas for forces and moments.

E.1.2 For machinery primarily designed for low pressures (such as axial compressors, low-pressure overhung compressors or compressors or machinery designed with open impellers that rely upon close radial and axial clearances of the impeller to the casing), the vendor shall identify the maximum allowable forces and moments.

E.2 Equations

The design of each compressor body must allow for limited piping loads on the various casing nozzles. For maximum system reliability, nozzle loads imposed by piping should be as low as possible regardless of the compressor's machines' load-carrying capability. As a standard, for cast axially split centrifugal compressors, radially split centrifugal compressors and higher pressure, over 50 psig inlet pressure, overhung single-stage compressors the forces and moments acting on compressors due to the inlet, side stream, and discharge connections should be limited by the following:

a. The total resultant force and total resultant moment imposed on the compressor at any connection should not exceed the values shown in Equations 2.E-1a or 2.E-1b.

In SI units:

$$F_r + 1.09 M_r \leq 54.1 D_e \quad (2.E-1a)$$

In U.S. Customary units:

$$3F_r + M_r \leq 927 D_e \quad (2.E-1b)$$

where

F_r = resultant force, in Newtons (lb.) (see Figure 2.E-1),

$$F_r = \sqrt{F_x^2 + F_y^2 + F_z^2} \quad (2.E-2)$$

M_r = resultant moment, in Newton-meters (ft-lb.) from Figure 2.E-1.

$$M_r = \sqrt{M_x^2 + M_y^2 + M_z^2} \quad (2.E-3)$$

For sizes up to 200 mm (8 in.) in diameter:

D_e = nominal pipe diameter of the connection, in mm (in.).

For sizes greater than 200 mm (8 in.), use a value of:

In SI units:

$$D_c = \frac{(400 + D_{nom})}{3} (\text{mm}) \quad (2.E-4a)$$

In U.S. Customary units:

$$D_c = \frac{(16 + D_{nom})}{3} (\text{in.}) \quad (2.E-4b)$$

where

D_c = equivalent pipe diameter of the connection, in mm (in.),

D_{nom} = nominal pipe diameter, in mm (in.).

b. The combined resultants of the forces and moments of the inlet, sidestream, and discharge connections resolved at the centerlines of the largest connection should not exceed the following:

1. The resultants shall not exceed:

In SI units:

$$F_c + 1.64 M_c \leq 40.4 D_c \quad (2.E-5a)$$

In U.S. Customary units:

$$2F_c + M_c \leq 462 D_c \quad (2.E-5b)$$

where

F_c = combined resultant of inlet, sidestream, and discharge forces, in Newtons (lb.),

M_c = combined resultant of inlet, sidestream, and discharge moments, and moments resulting from forces, in Newton-meters (ft-lb.),

D_c = diameter (in mm [in.]) of one circular opening equal to the total areas of the inlet, sidestream, and discharge openings. If the equivalent nozzle diameter is greater than 230 mm (9 in.), use a value of D_c equal to:

In SI units:

$$= \frac{(460 + \text{Equivalent Diameter})}{3} (\text{mm})$$

In U.S. Customary units:

$$= \frac{(18 + \text{Equivalent Diameter})}{3} (\text{in.})$$

2. The individual components (see Figure 2.E-1) of these resultants should not exceed:

In SI units:

$$F_x = 16.1D_c \quad M_x = 24.6D_c$$

$$F_y = 40.5D_c \quad M_y = 12.3D_c$$

$$F_z = 32.4D_c \quad M_z = 12.3D_c$$

In U.S. Customary units:

$$F_x = 92D_c \quad M_x = 462D_c$$

$$F_y = 231D_c \quad M_y = 231D_c$$

$$F_z = 185D_c \quad M_z = 231D_c$$

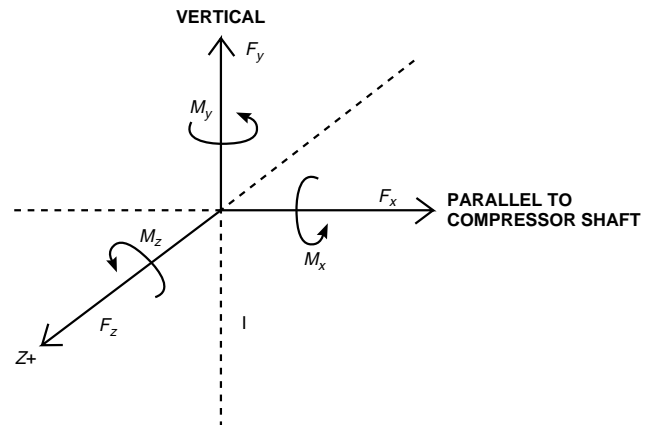

Figure 2.E-1—Combined Resultants of the Forces and Moments of Corrections

where

F_x = horizontal component of F_c parallel to the compressor shaft, in Newtons (lb.),

F_y = vertical component of F_c , in Newtons (lb.),

F_z = horizontal component of F_c at right angles to be compressor shaft, in Newtons (lb.),

M_x = component of M_c around the horizontal axis, in Newton-meters (ft-lb.),

M_y = component of M_c around the vertical axis, in Newton-meters (ft-lb.),

M_z = component of M_c around the horizontal axis at right angles to the compressor shaft, in Newton-meters (ft-lb.).

c. These values of allowable forces and moments pertain to the compressor structure only. They do not pertain to the forces and moments in the connecting pipes, flanges, and flange bolting, which should not exceed the allowable stress as defined by applicable codes and regulatory bodies.

Loads may be increased by mutual agreement between the purchaser and vendor; however, it is recommended that expected operating loads be minimized.

Chapter 3

Integrally Geared Compressors

CONTENTS

	Page
SECTION 1—GENERAL	3-1
1.1 Scope	3-1
1.2 Definition of Terms	3-1
SECTION 2—BASIC DESIGN	3-1
2.1 General	3-1
2.2 Materials	3-1
2.3 Casings	3-1
2.4 Inlet and/or Diffuser Guide Vanes	3-2
2.5 Rotating Elements	3-2
2.6 Dynamics	3-2
2.7 Bearings and Bearing Housings	3-2
2.8 Shaft End Seals	3-3
2.9 Gears	3-3
2.10 Lubrication and Sealing Systems	3-5
2.11 Nameplates and Rotation Arrows	3-5
SECTION 3—ACCESSORIES	3-6
3.1 Drivers	3-6
3.2 Couplings and Guards	3-6
3.3 Mounting Plates	3-6
3.4 Controls and Instrumentation	3-6
3.5 Piping and Appurtenances	3-6
3.6 Special Tools	3-7
SECTION 4—INSPECTION, TESTING, AND PREPARATION FOR SHIPMENT	3-7
4.1 General	3-7
4.2 Inspection	3-7
4.3 Testing	3-7
SECTION 5—VENDOR'S DATA	3-9
5.1 General	3-9
ANNEX 3A TYPICAL DATA SHEETS	3-11
ANNEX 3B INTEGRALLY GEARED COMPRESSOR VENDOR DRAWING AND DATA REQUIREMENTS	3-21
ANNEX 3C INTEGRALLY GEARED COMPRESSOR NOMENCLATURE (NORMATIVE)	3-29
ANNEX 3D INSPECTOR'S CHECK LIST	3-33
ANNEX 3E EXTERNAL FORCES AND MOMENTS	3-37
ANNEX 3F RATING FORMULAS FOR INTEGRALLY GEARED COMPRESSOR GEARING	3-39
Figures	
3.2-1 Face Width Limit	3-5
3.C-1 Typically Integrally Geared Compressor Showing Nomenclature of Key Parts	3-30

3.C-2 Typically Integrally Geared Compressor Arrangement Showing
Nomenclature of Key Elements3-31

3.C-3 Typically Integrally Geared Compressor Arrangement3-32

Tables

3.2-1 Drain Pipe Sizes3-4

SECTION 1—GENERAL

1.1 SCOPE

This chapter, in conjunction with Chapter 1 of this standard, covers the minimum requirements for integrally geared process centrifugal compressors used in process air or gas services.

See API Std 672 for packaged plant instrument air compressors.

Note: Expander stages are sometimes provided on these machines.

1.2 DEFINITION OF TERMS

1.2.1 Definitions of terms used in this chapter may be found in Chapter 1 of this standard. A cross-section showing nomenclature of an integrally geared centrifugal compressor may be found in Annex 3C.

SECTION 2—BASIC DESIGN

2.1 GENERAL

2.1.1 Performance

2.1.1.1 The sectional head-capacity characteristic curve of each compressor section shall rise continuously from the rated point to predicted surge. The compressor, without the use of a bypass, shall be suitable for continuous operation at any capacity at least 10% greater than the predicted surge capacity shown in the proposal.

2.2 MATERIALS

Materials shall be in accordance with 2.2 of Chapter 1.

2.3 CASINGS

Casings shall be in accordance with 2.3 of Chapter 1 and 2.3.1 through 2.3.4, as follows.

2.3.1 Pressure Casings

- **2.3.1.1** The maximum allowable working pressure of each pressure casing shall be at least equal to the specified relief valve setting for that casing. The purchaser will specify the relief valve setting(s) for final discharge pressure and intermediate casing pressures, if applicable.

Note: If only one relief valve pressure is specified, its set point may not apply to the intermediate pressure.

- **2.3.1.2** When a relief valve setting is not specified, each pressure casing shall be rated for the settleout pressure, or at least 1.25 times the maximum discharge pressure (gauge) of that pressure casing as determined by the vendor.

Note: The purchaser shall furnish system protection.

2.3.1.3 Socket-head or spanner-type bolting shall not be used externally unless specifically approved by the purchaser. For limited space locations, integrally flanged fasteners may be required.

2.3.2 Pressure Casing Connections

Pressure casing connections shall be in accordance with 2.3.2 in Chapter 1.

2.3.2.1 Main Process Connections

Main process connections shall be in accordance with 2.3.2.2 in Chapter 1.

2.3.2.2 Auxiliary Connections

2.3.2.2.1 If flanged or machined and studded openings are impractical, threaded connections may be used where they do not come in contact with flammable or toxic gas, with purchaser approval as follows:

- a. On non-weldable materials, such as cast iron.
- b. Where essential for maintenance (disassembly and assembly).

These threaded opening shall be as specified in 2.3.2.3.5.1 through 2.3.2.3.5.5.

Note: NP designates pipe per ANSI/ASME B1.20.1.

2.3.2.2.2 Auxiliary connections shall be at least DN 20 (3/4-in. NPT). See 2.9.1.7 through 2.9.1.9 for auxiliary gearbox connections.

Note: See 2.3.2.2.3 of Chapter 1 for allowable connection sizes.

2.3.2.2.3 Threaded connections for pipe sizes DN 20 (3/4-in. NPT) through DN 40 (1 1/2-in. NPT) size are permissible with the approval of the purchaser.

2.3.3 Pressure Casing Support Structure

The mounting of the pressure casing (volute) to the gearbox shall be per 2.1.7 in Chapter 1. Bolting used to mount pressure casings shall be per 2.3.1.7 in Chapter 1.

2.3.4 External Forces and Moments

2.3.4.1 The vendor shall furnish the allowable forces and moments for each nozzle in tabular form with the proposal.

Note: Forces and moments allowed on integrally geared compressors are generally less than allowed on Chapter 2 compressors.

2.3.4.2 Pressure casing and supports shall be designed to have sufficient strength and rigidity to avoid adversely affecting impeller running clearances, gear contact pattern, seals, bearings and coupling alignment.

2.4 INLET AND/OR DIFFUSER GUIDE VANES

- **2.4.1** Adjustable guide vanes shall be provided when specified or required by the vendor to meet specified operating conditions.
- 2.4.2** When provided, adjustable vanes and operating mechanisms shall be suitable for all specified operating conditions, as well as start-up, shutdown, trip-out, settling-out, and momentary surge.
 - 2.4.2.1** Guide vanes shall be mounted in replaceable bushings. Vanes may be positioned in the housing by replaceable permanently sealed anti-friction rolling element bearings, if approved by the purchaser.
 - 2.4.2.2** When inlet guide vanes are used for toxic, flammable or explosive process gas, then the linkage passing through the casing or enclosure shall be sealed to prevent leakage.
 - 2.4.2.3** The inlet guide vanes shall be located as closely as possible to the eye of the impeller.
 - 2.4.2.4** The vane foils shall have an aerodynamically smooth surface, especially where the shank enters the gas stream through the housing. A cantilevered design in lieu of a center supported vane design is preferred.
 - 2.4.2.5** The vanes shall be designed such that the vanes will tend to open on loss of the control signal.
- **2.4.3** When specified, the actuation shaft seal shall be buffered using a barrier gas.

2.5 ROTATING ELEMENTS

- 2.5.1** Each impeller and shaft shall be clearly marked with a unique identification number. This number shall be on an accessible area that is not prone to maintenance damage.
- 2.5.2** Unless other shaft protection is approved by the purchaser, renewable components shall be furnished at close-clearance points. Sleeves, spacers or bushings shall be made of materials that are corrosion-resistant in the specified service (see 2.2.1.6 in Chapter 1 for limitations).
 - 2.5.2.1** Shaft sleeves shall be provided under shaft end seals. Sleeves shall be treated to resist wear and sealed to prevent gas leakage between the shaft and sleeve.
 - 2.5.2.2** Shaft sleeves shall be provided under interstage seals. Closed impeller eye seals/bushings, which are stationary, do not require replaceable sleeves.

2.5.3 Thrust Balancing

Thrust loads from impellers and gears shall be absorbed by individual thrust bearings on pinions, or transmitted to the bull gear thrust bearing by means of thrust rider rings fixed to the pinions and bull gear. All specified operating conditions and start-up conditions shall be evaluated for residual thrust loads.

Note: Balance pistons are normally not used. Thrust balancing may be achieved by helix thrust force direction of the gearing and offsetting impeller aerodynamic thrust forces.

2.5.4 Impellers

Impeller requirements are covered in 2.5.10 of Chapter 1.

2.6 DYNAMICS

Dynamics shall be in accordance with 2.6 in Chapter 1.

2.7 BEARINGS AND BEARING HOUSINGS

2.7.1 General

- 2.7.1.1** Bearings shall be designed to prevent backwards and/or upside down installation.
- 2.7.1.2** Unless otherwise specified, radial and thrust bearings shall be of the hydrodynamic fluid film type.
- 2.7.1.3** Unless otherwise specified, thrust bearings and radial bearings shall be fitted with bearing-metal temperature sensors installed in accordance with API Std 670.
 - 2.7.1.3.1** As a design criteria, bearing metal temperatures shall not exceed 100°C (212°F) at specified operating conditions with a maximum oil inlet temperature of 50°C (120°F).
 - 2.7.1.3.2** In the event the above design criteria cannot be met, purchaser and vendor shall mutually agree on acceptable bearing metal temperatures.

2.7.2 Hydrodynamic Radial Bearings

- 2.7.2.1** Sleeve or pad radial bearings shall be used and shall be split for ease of assembly. The use of non-split designs requires the purchaser's approval. The bearings shall be precision bored with steel, copper, cupro-nickel or bronze-backed babbitted liners, pads, or shells. The bearings shall be equipped with anti-rotation pins and shall be positively secured in the axial direction.
- **2.7.2.2** When specified, tilting pad bearings shall be copper-alloy backed and shall have hardened steel inserts for support.
- 2.7.2.3** Unless otherwise specified, the liners, pads, or shells shall be in axially split housings. The bearing design shall not require removal of the coupling hub to permit replacement of the bearing liners, pads, or shells unless approved by purchaser.

2.7.2.4 The bearing design shall suppress hydrodynamic instabilities and provide sufficient damping over the entire range of allowable bearing clearances to limit rotor vibration to the maximum specified amplitudes (see 2.6.8.8 of Chapter 1), while the equipment is operating loaded or unloaded, including operation at any critical frequency within the specified operating speed range.

2.7.3 Hydrodynamic Thrust Bearings

2.7.3.1 Thrust bearings may be fixed geometry (e.g., tapered-land) or tilting-pad type, steel-backed and babbitted, arranged for continuous pressurized lubrication to each side.

Note: See 2.5.3 for thrust rider rings.

- **2.7.3.2** When specified, bearings shall be tilting pad on one or both sides.

2.7.3.3 Hydrodynamic thrust bearings shall be selected at no more than 50% of the bearing manufacturer's ultimate load rating. The ultimate load rating is the load that will produce the minimum acceptable oil film thickness without inducing failure during continuous service, or the load that will not exceed the creep initiation or yield strength of the babbitt or bearing material at the location of maximum temperature on the pad, whichever load is less. In sizing thrust bearings, consider the following for each specified application:

- a. The shaft speed.
- b. The temperature of the bearing babbitt.
- c. The deflection of the bearing pad.
- d. The minimum oil film thickness.
- e. The feed rate, viscosity, and supply temperature of the oil.
- f. The design configuration of the bearing.
- g. The babbitt or other bearing surface material alloy and pad material.
- h. The turbulence of the oil film.

2.7.3.4 Thrust bearings shall be sized for continuous operation under the most adverse specified operating conditions. Calculations of the thrust forces shall include but shall not be limited to the following factors:

- a. Seal maximum design internal clearances and twice the maximum design internal clearances.
- b. Pressurized rotor diameter step changes.
- c. Stage maximum differential pressures.
- d. Specified extreme variations in inlet, interstage, and discharge pressures.
- e. The maximum thrust force that may be transmitted to the compressor thrust bearing by other equipment in the train (i.e., couplings, gears, or a motor without a thrust bearing).
- f. The maximum thrust force from the sleeve bearing type drive if the motor or generator is directly connected.

2.7.4 Bearing Housings

2.7.4.1 The term bearing housing refers to all bearing enclosures including, the gearbox.

2.7.4.2 Bearing housings for pressure-lubricated hydrodynamic bearings shall be arranged to minimize foaming. The drain system shall be adequate to maintain the oil and foam level below shaft seals.

2.7.4.3 Oil reservoirs and housings that enclose moving lubricated parts (such as bearings and shaft seals), highly polished parts, instruments, and control elements shall be designed to minimize contamination by moisture, dust, and other foreign matter during periods of operation and idleness.

2.7.4.4 Provision shall be made in the bearing housings for the probes specified in 3.4.7.6.

2.8 SHAFT END SEALS

2.8.1 Process seals and seal systems shall be in accordance with 2.8 of Chapter 1 of this standard.

Note 1: Typical cross sections of various seal systems are given in Annex 1C. The purchaser and vendor must mutually agree on the suitability of a particular seal for the service.

Note 2: Equipment covered in this chapter may be available with any of the shaft end seal types covered in Chapter 1, or additional hybrid types may be available.

2.9 GEARS

This section covers integral gearing. For separate gearboxes, see 3.1.8 in Chapter 1.

2.9.1 Gearboxes

2.9.1.1 The vendor shall dowel or key the gearbox to the mounting plate to maintain alignment.

Note: Integrally geared compressors are fixed to the mounting plate and should not normally be moved for alignment (to avoid distortion of the gearbox).

2.9.1.2 To the maximum extent practical, gearboxes shall be designed with internal oil passages to minimize external piping. External piping connections shall conform to the requirements of 2.3.2.3 in Chapter 1.

2.9.1.3 The design of internal piping and tubing shall achieve proper support and protection to prevent damage from vibration or from shipment, operation, and maintenance. Cantilevered piping in excess of 10 pipe diameters shall include reinforcing gussets in two planes at all pipe-to-flange connections.

2.9.1.4 The gearbox shall be designed to permit rapid drainage of lube oil and to minimize oil foaming (which could lead to excessive heating of the oil). For gears with pitch line velocities of more than 125 m/sec. (25,000 ft/min.),

consideration should be given to design features such as windage baffles, false bottoms, adequate sump depth, and an additional full-size drain connection.

2.9.1.5 A removable and gasketed inspection cover or covers shall be provided in the gearbox to permit direct visual inspection of the full-face width of the pinion(s) and gear. The inspection opening or openings shall be at least one-half the width of the gear face.

2.9.1.6 Permanent coatings or paint shall not be applied to the interior of the casing, unless the purchaser approves in advance the material and method of application.

2.9.1.7 A single lube-oil supply connection is preferred.

2.9.1.8 A single lube-oil drain connection from the gear casing is preferred. The minimum drainpipe size shall be based on the total inlet flow to the gear casing, as shown in Table 3.2-1 below.

Table 3.2-1—Drain Pipe Sizes

Inlet Flow Rate		Minimum Drain Size	
Liters per Min.	Gallons per Min.	Millimeters	In.*
26	7	75	3
56	15	100	4
170	45	150	6
380	100	200	8
585	155	250	10
830	220	300	12
1000	264	350	14

*Nominal Pipe Size

2.9.1.9 Gearboxes shall be provided with a plugged or flanged-and-blinded purge gas connection.

2.9.2 Gearbox Split Lines

Gearbox split lines shall use a metal-to-metal joint. Adequate sealing shall be provided with a suitable joint compound or groove type seals. Gaskets (including string type) shall not be used on the gearbox split lines.

2.9.3 Gear Rating

2.9.3.1 When a gearbox has any gear mesh with a ratio of 7:1 or greater, then all of the gearing in that gearbox shall be rated in accordance with Annex 3F. All other gear sets shall be rated per API Std 613.

2.9.3.2 The rated power of the gearing shall not be less than the driver nameplate rating multiplied by the driver service factor. When there are multiple pinions, the power rating of the gear sets shall not be less than:

- 110% of the maximum power transmitted by the gear set.
- The maximum power of the driver (including service fac-

tor) prorated between all the gear sets, based on normal power demands.

If the maximum transmitted torque occurs at a continuous operating speed other than the maximum continuous speed, this torque and its corresponding speed shall be the basis for sizing the gear set.

2.9.3.3 The power rating based upon both pitting resistance and bending strength must be calculated for each member of each gear set in the unit. The pinion and bull gear teeth may have different ratings due to differences in material properties, geometry factors, and number of cycles under load. The lowest of the four ratings (pinion bending, pinion pitting, bull gear bending, bull gear pitting) shall be used as the gear rating (see Annex 3F). Wherever possible, gear sets shall be designed such that failure will occur due to pitting rather than bending (i.e., wear out before breaking).

Note: Higher gear ratios require a large number of teeth, therefore, it may not be possible to provide tooth design (which will fail in pitting rather than bending) without compromising other aspects of the gear design (i.e., higher pitchline velocities).

2.9.3.4 Gearing shall be designed and manufactured to meet the tolerance (referred to as deviation in ISO) of ISO 1328, Grade 4.

Note: For equivalent loading conditions, gearing produced to higher quality levels will always result in longer service life and reduced bearing loads. The ISO tolerancing system has replaced the AGMA system of quality numbers. An approximate comparison is to subtract the ISO number from 17 to arrive at the closest AGMA quality number.

2.9.3.5 The manufacturer shall provide documentation showing that the required quality levels in 2.9.3.4 have been met.

2.9.3.6 The pinion face width to working pitch diameter ratio (L/d ratio) shall be limited based on pinion tooth hardness, as follows:

2.9.3.6.1 For pinion hardness equal to or less than 38 Rc (BHN 354), L/d shall be limited to 2.0 maximum.

2.9.3.6.2 For pinion hardness equal to or greater than 58 Rc (BHN 615), L/d shall be limited to 1.6 maximum.

2.9.3.6.3 For pinion hardness between 38 and 58 Rc (BHN 354 and BHN 615), L/d shall be limited to $L/d = 2.76 - 0.02 * H$ (see Figure 3.2-1).

Note: H = hardness in Rockwell C.

2.9.3.7 The material used for gearing shall meet the specifications for AGMA 2101 Grade 2 material, as a minimum. If a superior grade of material is used, credit for the better material shall not be taken in the gear rating.

2.9.3.8 The tooth portion of pinions shall be integral with their shafts.

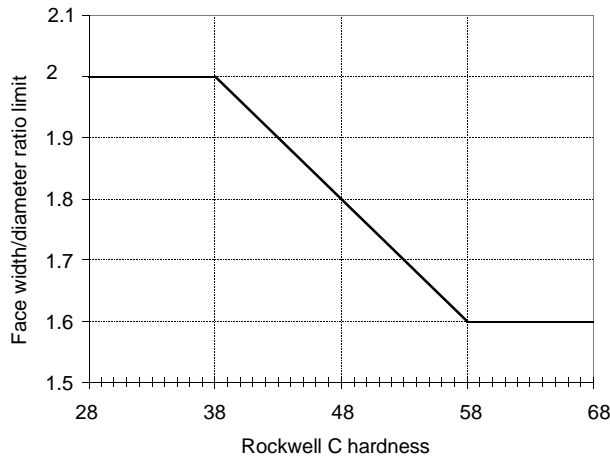

Figure 3.2-1—Face Width Limit

2.9.3.9 The bull gear may be integral with or separate from its shaft. Separate shafts shall be assembled into the bull gear with an interference fit suitable for all torque requirements.

Note: Special consideration may be required for synchronous motor drives.

2.9.3.10 Shafts shall be made of one-piece, heat-treated steel that is suitably machined. Shafts that have a finished diameter larger than 200 mm (8 in.) shall be forged steel. Shafts that have a finished diameter of 200 mm (8 in.) or less shall be forged steel or, with the purchaser's approval, hot rolled barstock, providing such barstock meets all quality and heat treatment criteria established for shaft forgings.

2.9.3.11 Gearboxes shall not require a break-in period.

2.9.3.12 The gearing shall be designed to withstand all internal and external loads inherent to geared, rotating machinery systems to the limit of the installed driver. In addition, the gearing shall comply with the requirements of 2.6.6 of Chapter 1.

2.9.3.13 The unplated tooth surface on loaded faces of completed gears shall have a finish, as measured along the pitch line, of 0.8 μm (32 $\mu\text{in.}$) Ra or better.

2.9.3.14 Teeth may be silver or copper plated to provide added protection from scoring during initial operation. The purchaser and the vendor shall mutually determine the desirability of such plating.

2.9.3.15 Hunting tooth combinations are preferred. To achieve this, it may be necessary for the manufacturer to adjust the exact gear ratio. If such adjustment is impractical, the purchaser and the vendor shall negotiate a solution. At least one mesh shall be hunting tooth.

Note: A hunting tooth combination is preferred because the intent is for every tooth on a pinion to mesh with as many teeth as possible on

the mating gear before the same teeth mesh again or repeat. However, with multiple pinion units a hunting tooth combination is not as critical because the gear wheel meshes with multiple pinions and is, therefore, not as susceptible to the problems of non-hunting tooth designs.

2.9.3.16 Each gear and each pinion shall be supported between two bearings. Overhung designs are not permitted.

2.10 LUBRICATION AND SEALING SYSTEMS

2.10.1 Oil systems shall be in accordance with 2.10.3 of Chapter 1.

2.10.2 Unless otherwise specified, the lubricant shall be hydrocarbon oil of viscosity Grade 32 with an FZG load stage of 5, in accordance with ISO 8068. When required for gearing, viscosity Grade 46 with an FZG load stage of 5 may be used, with purchaser's approval. Oils with extreme pressure (EP) additives shall not be used.

2.11 NAMEPLATES AND ROTATION ARROWS

2.11.1 Nameplates and rotation arrows shall be in accordance with 2.11 of Chapter 1, and this section.

• **2.11.2** The following data shall be clearly stamped or engraved on the nameplate(s):

- Vendor's name.
- Serial number.
- Size, type and model.
- Rated capacity.
- Rated power.
- Number of teeth on each pinion.
- Number of teeth on the gear wheel.
- Gear ratio.
- Rated input speed.
- Rated output speed of each pinion.
- Lateral critical speeds up to and including the next lateral above maximum allowable speed (see 2.11.2.1 of Chapter 2 of this standard).
- Purchaser item number.
- Maximum allowable working pressure of each pressure-containing casing.
- Maximum and minimum allowable working temperature of each pressure-containing casing.
- Minimum and maximum allowable speed(s) for each rotor.
- Hydrostatic test pressure for each pressure-containing casing.
- Gear service factor.

The purchaser will specify whether SI or U.S. Customary units are to be shown.

Note: Normally, multiple nameplates are provided.

2.11.2.1 Lateral critical speeds exhibited during the running tests shall be stamped on the nameplate followed by the

word “test.” Lateral critical speeds predicted by calculation up to and including the critical speed above trip speed and not identifiable by test shall be stamped on the nameplate and noted as a calculated value.

2.11.3 Rotation arrows shall be cast-in or attached to each major item of rotating equipment at a readily visible location (see 2.11 of Chapter 1).

SECTION 3—ACCESSORIES

Accessories shall conform with Section 3 of Chapter 1.

3.1 DRIVERS

Drivers shall conform with 3.1 in Chapter 1.

3.2 COUPLINGS AND GUARDS

Couplings and guards shall conform with 3.2 in Chapter 1.

3.3 MOUNTING PLATES

Mounting plates shall conform with 3.3 of Chapter 1.

3.4 CONTROLS AND INSTRUMENTATION

3.4.1 Controls and instrumentation shall be in conformance with 3.4 of Chapter 1.

3.4.2 Control Systems

- **3.4.2.1** For a constant-speed centrifugal compressor, the control signal shall actuate either a purchaser-furnished control valve in the compressor inlet piping or the adjustable inlet guide vanes or variable diffuser vanes furnished by the vendor as an integral part of the compressor, as specified. In the latter case, the vendor shall also furnish a guide-vane positioner compatible with the type of control signal specified by the purchaser. When specified, the guide vane positioner shall include a local manual override. A direct-driven vane position indicator shall be provided that will be visible during operation of the machine.

3.4.3 Instrument and Control Panels

Instrument and control panels, when supplied, shall be in accordance with 3.4.3 in Chapter 1.

3.4.4 Instrumentation

Instrumentation, when supplied, shall be in accordance with 3.4.4 of Chapter 1.

3.4.5 Alarms and Shutdowns

Alarms and shutdowns, when supplied, shall be in accordance with 3.4.5 of Chapter 1.

3.4.6 Electrical Systems

Electrical systems, when supplied, shall be in accordance with 3.4.6 of Chapter 1.

3.4.7 Vibration, Position, and Bearing Temperature

3.4.7.1 Unless otherwise specified, vibration and axial-position transducers shall be supplied, installed, and calibrated in accordance with API Std 670.

- **3.4.7.2** When specified, radial shaft vibration and axial-position monitors shall be supplied and calibrated in accordance with API Std 670.

- **3.4.7.3** When specified, a bearing temperature monitor shall be supplied and calibrated according to API Std 670.

3.4.7.4 Unless otherwise specified, accelerometers shall be supplied, installed at each shaft on the gearbox, and calibrated in accordance with API Std 670.

- **3.4.7.5** When specified, gearbox vibration monitors shall be supplied, installed and calibrated in accordance with API Std 670.

3.4.7.6 Two radial-vibration probes shall be mounted in each bearing housing, in addition, two axial-position probes on each shaft in the machine equipped with a thrust bearing, and a one-event-per-revolution probe at each shaft. The probe installation shall be as specified in API Std 670.

- **3.4.7.7** When specified, accelerometer(s) shall be mounted on the gearbox near the pinion bearing(s) to measure gearmesh vibration. Monitors, when supplied, shall be suitable for measuring gearmesh frequencies.

3.5 PIPING AND APPURTENANCES

3.5.1 General

Piping and appurtenances furnished shall be in accordance with 3.5 in Chapter 1 of this standard, with additions as follows:

3.5.1.1 When a baseplate has been specified, the vendor shall furnish all piping systems, including mounted appurtenances, located within its confines. The piping shall terminate with flanged connections at the edge of the baseplate. The purchaser will furnish only interconnecting piping between equipment groupings and off base facilities.

- **3.5.1.2** When soleplates are specified, the purchaser shall define the extent of the piping system supplied by the vendor.
- **3.5.1.3** When specified, a liquid injection manifold shall be supplied. It shall include a throttle valve, an armored flow meter, a check valve, a pressure indicator, and a block valve for each injection point.

3.5.2 Process Piping and Accessories

3.5.2.1 Process piping, if furnished, including intercon-

necting piping, shall be in accordance with API Std 614 Chapter 1, 2.4.

- **3.5.2.2** When specified, the purchaser shall provide specifications for process heat exchangers and interconnecting piping to be provided by the vendor with API Std 614 Chapter 1, 5.5.

3.6 SPECIAL TOOLS

Special tools shall be in accordance with 3.6 of Chapter 1.

SECTION 4—INSPECTION, TESTING, AND PREPARATION FOR SHIPMENT

4.1 GENERAL

General requirements for inspection, testing and preparation for shipment shall be in accordance with Section 4 in Chapter 1. Also refer to Annex 3D for Inspector's Checklist.

4.2 INSPECTION

Requirements for inspection shall be in accordance with 4.2 of Chapter 1 of this standard and the following:

4.2.1 Gear Contact Checks

4.2.1.1 Each set of installed gears shall be checked for contact in the job gearbox at the vendor's shop.

4.2.1.2 A thin coating of color transfer material (such as Prussian blue) shall be applied at three locations, 120 degrees apart, to four or more teeth of the dry degreased gear. (Layout dye shall not be used for the assembly contact check.) With the gear held firmly, the coated teeth shall be rotated through the mesh with a moderate drag torque applied in a direction that will cause the teeth to contact on the normally loaded faces. The color transfer shall show evidence of contact distributed across each helix, as prescribed by the vendor. Prior to the contact tests, the vendor shall make available to the purchaser a contact drawing or vendor engineering specification that defines the acceptable contact. The results of the contact check shall be preserved by lifting the contrasting colors from a tooth by applying and peeling off a strip of clear, adhesive tape and then applying the tape to a notated sheet of white paper. The drawing or specification and the results of the contact checks shall be preserved for at least 20 years and shall be available to the purchaser on request.

Note: Unmodified leads generally show about 80% contact across the tooth length.

4.3 TESTING

In addition to the requirements of Chapter 1, 4.3, the machines shall be tested in accordance with 4.3.1 and 4.3.2.

Other tests that may be specified are described in 4.3.3 and 4.3.4.

4.3.1 Mechanical Running Test

4.3.1.1 The requirements of 4.3.1.1.1 through 4.3.1.1.10 shall be met before the mechanical running test is performed.

4.3.1.1.1 The contract shaft seals and bearings shall be used in the machine for the mechanical running test.

- **4.3.1.1.2** Compressors covered in this chapter generally do not use oil-injected seals or seal-oil systems. When these are specified, testing shall be as mutually agreed upon between user and vendor.

Note: For guidance see Chapter 2, 4.3.1.

4.3.1.1.3 Oil viscosity, pressures, temperatures and filtration shall be within the range of operating values recommended in the vendor's operating instructions for the specific unit being tested. Overall oil flow rates for each oil supply line shall be measured.

4.3.1.1.4 Oil system components downstream of the filters shall meet the cleanliness requirements of API Std 614 before any test is started.

4.3.1.1.5 All joints and connections shall be checked for tightness, and any leaks shall be corrected.

4.3.1.1.6 All warning, protective, and control devices used during the test shall be checked, and adjusted as required.

4.3.1.1.7 Facilities shall be installed to prevent the entrance of oil into the compressor during the mechanical running test. These facilities shall be in operation throughout the test.

4.3.1.1.8 Testing with the contract coupling(s) is preferred.

4.3.1.1.9 All contract vibration probes, transducers, oscillator-demodulators, and accelerometers shall be in use during the test.

4.3.1.1.10 Shop test facilities shall include the capability of continuously monitoring, displaying, recording and printing vibration displacement and phase, vibration spectra, Bode plots, and shaft orbits.

4.3.1.1.11 The vibration characteristics determined using the instrumentation specified in 4.3.1.1.9 and 4.3.1.1.10 shall serve as the basis for acceptance or rejection of the machine (see 2.6.8.8 of Chapter 1).

4.3.1.2 The mechanical running test of the equipment shall be conducted as specified in 4.3.1.2.1 through 4.3.1.2.4.

4.3.1.2.1 The equipment shall be accelerated to the maximum continuous speed and run until bearings, lube-oil temperatures, and shaft vibrations have stabilized.

Note: Operating equipment at or near critical speeds should be avoided.

4.3.1.2.2 The speed shall be increased to trip speed and the equipment shall be run for a minimum of 15 min.

4.3.1.2.3 The speed shall be reduced to the maximum continuous speed, and the equipment shall be run for 4 hours continuous operation.

4.3.1.2.4 The following seal flow data shall be taken during the mechanical running test to assure that the seals are installed and operating properly:

- a. For single dry gas seals, flow in the vent line from each seal shall be measured.
- b. For tandem dry gas seals, flow in the primary and secondary vent line from each seal shall be measured.
- c. For double dry gas seals, the total flow to each seal shall be measured.

Note 1: Seal performance at contract conditions is normally determined in separate tests by the seal manufacturer (see Chapter 1, 2.8 for the requirements).

Note 2: Flow in the vents of single or tandem seals may include buffer or separation gas in addition to process gas leakage through the seal.

4.3.1.3 During the mechanical running test, the requirements of 4.3.1.3.1 through 4.3.1.3.7 shall be met.

4.3.1.3.1 During the mechanical running test, the mechanical operation of all equipment being tested and the operation of the test instrumentation shall be satisfactory. The equipment measured unfiltered vibration shall not exceed the limits of 2.6.8.8 of Chapter 1 and shall be recorded at the operating speed. Any other test acceptance criteria shall be mutually agreed upon and stated in the test agenda.

4.3.1.3.2 When gear casing accelerometers are furnished, casing vibration shall not exceed an overall level of 4 Gs peak at gear mesh frequency.

4.3.1.3.3 While the equipment is operating at maximum continuous speed or other speeds, vibration data shall be acquired to determine amplitudes at frequencies other than synchronous. This data shall cover a frequency range from 0.25 – 8 times the maximum continuous speed. If the amplitude of any discrete, nonsynchronous vibration exceeds 20% of the allowable vibration as defined in 2.6.8.8 of Chapter 1, the purchaser and the vendor shall mutually agree on requirements for any additional testing and on the equipment acceptability.

4.3.1.3.4 The mechanical running test shall verify that lateral critical speeds conform to the requirements of Chapter 1, 2.6.2.

4.3.1.3.5 Shop verification of the unbalanced response analysis shall be performed in accordance with Chapter 1, 2.6.2.

- **4.3.1.3.6** When specified, all real-time vibration data as mutually agreed by the purchaser and the vendor shall be recorded, and a copy provided to the purchaser.

- **4.3.1.3.7** When specified, the user may bring in the user's own vibration equipment to record baseline readings.

4.3.1.4 Following the mechanical running test, the requirements of 4.3.6.2.1 through 4.3.6.2.4 in Chapter 1 shall be met, as well as the requirements on 4.3.1.4.1 and 4.3.1.4.2 in Chapter 3.

4.3.1.4.1 The tooth mesh shall be inspected for proper contact, and for surface damage resulting from the test.

4.3.1.4.2 Spare rotor sets ordered to permit concurrent manufacture shall also be given a mechanical running test in accordance with the requirements of this standard. Complete spare set shall be run as a unit.

4.3.2 Assembled Compressor Gas Leakage Test

4.3.2.1 After the mechanical running test is completed, each completely assembled compressor casing intended for toxic, hazardous, or flammable service shall be tested as required in 4.3.2.2 and/or, when specified, 4.3.2.3.

Note: These tests are intended to verify the integrity of the casing joint. Some shaft seal designs are not gas tight. Therefore, leakage from these seals during this test is acceptable.

4.3.2.2 The assembled compressor (including end seals) shall be pressurized, with an inert gas, to the maximum sealing pressure or the maximum seal design pressure, as agreed upon by the purchaser and the vendor; held at no less than this pressure for a minimum of 30 min.; and subjected to a soap-bubble test, or alternate method, to check for gas leaks. The test shall be considered satisfactory when no casing or casing joint leaks are observed.

Note: Test gas mole weight should approximate or be less than contract gas mole weight. Helium for low mole weight contract

gas, and nitrogen or refrigerant gas for high mole weight should be considered.

- **4.3.2.3** When specified, the assembled compressor (with or without end seals installed) shall be pressurized with an inert gas to the maximum specified discharge pressure, held at this pressure for a minimum of 30 min., and subjected to a soap-bubble test, or alternate method, to check for gas leaks. The test shall be considered satisfactory when no casing or casing joint leaks are observed.

Note: The requirements of 4.3.2.2 and 4.3.2.3 may necessitate two separate tests.

● 4.3.3 Optional Tests

The purchaser will specify whether any of the following shop tests shall be performed. The purchaser and the vendor shall mutually agree upon test details prior to the test.

4.3.3.1 Performance Test

- **4.3.3.1.1** The compressor shall be performance tested in accordance with ASME PTC 10-1997 or ISO 5389, as specified. A minimum of five points, including surge and overload, shall be taken at normal speed and vane setting. For variable speed or variable vane machines, additional points may be specified.

Note: Refer to the applicable test code for general instructions. ASME PTC 10-1997 may not apply to some low-pressure ratio compressors. Refer to the scope 1.2.2 of PTC 10-1997 for the selection of the appropriate test code to be used.

4.3.3.1.2 For variable speed or variable vane machines, head and capacity shall have zero negative tolerance at the normal operating point (or other point as specified), and the power at this point shall not exceed 104% of the vendor predicted shaft power value. This tolerance shall be inclusive of all test tolerances. Surge shall comply with provisions of 2.1.1.1.

Note: Both of the performance test codes referred to have provision for calculating inaccuracy based on instrumentation and procedures. These test inaccuracies are already included in the above tolerance and, therefore, are not to be further additive.

4.3.3.1.3 For constant speed compressors, the capacity shall be as specified in 4.3.3.1.2. The head shall be within the range of 100% – 105% of the normal head. The horsepower, based on measured head at normal capacity, shall not exceed 107% of the value at the specified normal operating point. If the power required at this point exceeds 107%, excess head may be removed by trimming impellers at the purchaser's option.

4.3.3.1.4 The performance test shall be conducted using only one contract rotor set, unless additional performance testing is specified.

4.3.3.1.5 Compressors with intermediate specified process pressures shall have individual sectional head (pressure) tolerances as mutually agreed.

4.3.3.2 Complete Unit Test

Such components as compressors, gears, drivers, and auxiliaries that make up a complete unit shall be tested together during the mechanical running test. A separate auxiliary test may be performed with the purchaser's approval. The complete unit test may be performed in place of or in addition to separate tests of individual components specified by the purchaser. When specified, torsional vibration measurements shall be made to verify the vendor's analysis.

4.3.3.3 Testing of Stand-alone Gearboxes

For units with stand-alone gearboxes, the contract gear shall be tested with the machine(s) during the mechanical running test.

SECTION 5—VENDOR'S DATA

Vendor's data shall be in accordance with Section 5 of Chapter 1 of this standard.

5.1 GENERAL

5.1.1 The information to be furnished by the vendor is specified in Annex 3B and Section 5 of Chapter 1. The vendor shall complete and forward the VDDR form in Annex 3B to the address or addresses noted on the inquiry or order. This form shall detail the schedule for transmission of drawings,

curves, and data as agreed to at the time of the order, as well as the number and type of copies required by the purchaser.

5.1.2 On the data sheets and in drawings and tables, the shaft rotational direction shall be designated by the abbreviations CW or CCW (see 2.11.3).

5.1.3 Vendors shall provide bearing temperature alarm and shutdown limits on the datasheets.

.....

**ANNEX 3A
TYPICAL DATA SHEETS**

INTEGRALLY GEARED COMPRESSOR DATA SHEET (API 617—7TH Chapter 3) U.S. CUSTOMARY UNITS		JOB NO. _____ ITEM NO. _____ REVISION NO. _____ DATE _____ PAGE <u>2</u> OF <u>8</u> BY _____		
OPERATING CONDITIONS (Continued) (1-2.1.1.1) (1-3.1.2) (1-3.1.3)				
2	GAS ANALYSIS:		OTHER CONDITIONS	
3	<input type="radio"/> MOL % <input type="radio"/>	NORMAL	A B C D E	REMARKS:
4	MW			
5	AIR	28.966		
6	OXYGEN	32.000		
7	NITROGEN	28.016		
8	WATER VAPOR	18.016		
9	CARBON MONOXIDE	28.010		
10	CARBON DIOXIDE	44.010		
11	HYDROGEN SULFIDE	34.076		(1-2.2.1.6)
12	HYDROGEN	2.016		(1-2.2.1.9)
13	METHANE	16.042		
14	ETHYLENE	28.052		
15	ETHANE	30.068		
16	PROPYLENE	42.078		
17	PROPANE	44.094		
18	I-BUTANE	58.120		
19	n-BUTANE	58.120		
20	I-PENTANE	72.146		
21	n-PENTANE	72.146		
22	HEXANE PLUS			
23	CORROSIVE AGENTS			(1-2.2.1.3)
24				
25	TOTAL			
26	AVG. MOL. WT.			
27	LOCATION: (1-2.1.8) <input type="radio"/> INDOOR <input type="radio"/> OUTDOOR <input type="radio"/> GRADE <input type="radio"/> HEATED <input type="radio"/> UNDER ROOF <input type="radio"/> MEZZANINE <input type="radio"/> UNHEATED <input type="radio"/> PARTIAL SIDES <input type="radio"/> _____ <input type="radio"/> ELEC. AREA CLASSIFICATION (1-2.1.14) CL _____ GR _____ DIV _____		NOISE SPECIFICATIONS: (1-2.1.9) <input type="radio"/> APPLICABLE TO MACHINE: SEE SPECIFICATION _____ <input type="radio"/> APPLICABLE TO NEIGHBORHOOD: SEE SPECIFICATION _____ ACOUSTIC HOUSING: <input type="radio"/> YES <input type="radio"/> NO APPLICABLE SPECIFICATIONS: API 617, 7TH CHAPTERS 1 & 3 <input type="radio"/> VENDOR HAVING UNIT RESPONSIBILITY (1-1.5.53) (1-1.8) (1-2.1.3) _____ <input type="radio"/> GOVERNING SPECIFICATION (IF DIFFERENT) _____	
32	SITE DATA (1-2.1.8) <input type="radio"/> ELEVATION _____ FT BAROMETER _____ PSIA <input type="radio"/> RANGE OF AMBIENT TEMPS: DRY BULB WET BULB NORMAL °F _____ _____ MAXIMUM °F _____ _____ MINIMUM °F _____ _____ _____ °F _____ _____		PAINTING: <input type="radio"/> MANUFACTURER'S STD. <input type="radio"/> OTHER _____	
40	UNUSUAL CONDITIONS: <input type="radio"/> DUST <input type="radio"/> FUMES <input type="radio"/> OTHER (1-2.1.8) _____		NAMEPLATE (2-2.11.2) <input type="radio"/> US CUSTOMARY <input type="radio"/> METRIC	
44	<input type="radio"/> COPPER AND COPPER ALLOYS PROHIBITED (1-2.2.1.14)		SHIPMENT: (4.4) <input type="radio"/> DOMESTIC <input type="radio"/> EXPORT <input type="radio"/> EXPORT BOXING REQ'D. <input type="radio"/> OUTDOOR STORAGE MORE THAN 6 MONTHS (1-4.4.1) _____ MO <input type="radio"/> SPARE ROTOR ASSEMBLY PACKAGE (1-4.4.3.10) <input type="radio"/> HORIZONTAL STORAGE <input type="radio"/> VERTICAL STORAGE	
45	COATING: (1-2.2.1.16) <input type="radio"/> ROTATING COMPONENTS _____ <input type="radio"/> STATIONARY COMPONENTS _____			
48	REMARKS: _____			

INTEGRALLY GEARED COMPRESSOR DATA SHEET (API 617—7TH Chapter 3) U.S. CUSTOMARY UNITS		JOB NO. _____ ITEM NO. _____ REVISION NO. _____ DATE _____ PAGE <u>3</u> OF <u>8</u> BY _____					
CONSTRUCTION FEATURES (1 COLUMN PER STAGE, USE ADDITIONAL SHEETS IF NEEDED)							
1							
2	Rotor	Rotor 1					
3	Stage	Stage 1	Stage 2	Stage 3	Stage 4	Stage 5	Stage 6
4	<input type="checkbox"/> CASING:						
5	MODEL						
6	CASING SPLIT						
7	MATERIAL						
8	THICKNESS (IN.)						
9	CORROSION ALLOWANCE (IN.)						
10	MAX. ALLOWABLE PRESS (PSIG)						
11	TEST PRESS (PSIG):						
12	MAX. ALLOWABLE TEMP. (°F)						
13	MAX. OPERATING TEMP. (°F)						
14	MIN. OPERATING TEMPERATURE (°F)						
15	MAX CASING CAPACITY (ICFM)						
16	<input type="checkbox"/> INLET CONNECTIONS (1-2.3.2.2.1, 1-2.3.2.2.7)						
17	TYPE <input type="checkbox"/>						
18	ORIENTATION						
19	FLANGED OR STUDDED?						
20	MATING FLG & GASKET BY VENDOR?						
21	GAS VELOCITY (FT/SEC.)						
22	<input type="checkbox"/> DISCHARGE CONNECTIONS (1-2.3.2.2.1, 1-2.3.2.2.7)						
23	TYPE <input type="checkbox"/>						
24	ORIENTATION						
25	FLANGED OR STUDDED?						
26	MATING FLG & GASKET BY VENDOR?						
27	GAS VELOCITY (FT/SEC.)						
28	<input type="radio"/> INTERMEDIATE MAIN PROCESS CONNECTIONS (2-2.4.5)						
29	DISCH. PRESSURE (PSIG):						
30	INLET PRESSURE (PSIG):						
31	<input type="checkbox"/> ADJUSTABLE INLET GUIDE VANES						
32	MATERIAL _____						
33	NO. INLET GUIDE VANES						
34	<input type="checkbox"/> IMPELLER:						
35	DIAMETER						
36	NUMBER OF VANES						
37	TYPE (OPEN, ENCLOSED, ETC.)						
38	TYPE FABRICATION						
39	MATERIAL						
40	MIN. YIELD STRENGTH (PSI)						
41	HARDNESS: (Rc) (BRINNEL)						
42	SMALLEST TIP INTERNAL WIDTH (IN.)						
43	MAX. MACH. NO. @ IMPELLER EYE						
44	MAX. IMPELLER HEAD @ 100% SPD (FT)						
45	MAX. IMPELLER TIP SPEED (FT/MIN.)						
46	<input type="checkbox"/> DIFFUSER GUIDE VANES						
47	ADJUSTABLE?						
48	MATERIAL						
49	NO. GUIDE VANES						

CENTRIFUGAL AND AXIAL COMPRESSOR DATA SHEET (API 617—7TH Chapter 3) U.S. CUSTOMARY UNITS		JOB NO. _____ ITEM NO. _____ REVISION NO. _____ DATE _____ PAGE <u>4</u> OF <u>8</u> BY _____					
CONSTRUCTION FEATURES, continued (1 COLUMN PER STAGE, USE ADDITIONAL SHEETS IF NEEDED)							
		Stage 1	Stage 2	Stage 3	Stage 4	Stage 5	Stage 6
2	<input type="checkbox"/> SHAFT SLEEVES:						
3	MATERIAL _____						
4	AT SHAFT SEALS? _____						
5	OTHER LOCATIONS? _____						
6	SHAFT SEALS: (1-2.8.1.1, 1-2.8.1.5)						
7	<input type="radio"/> SEAL TYPE (1-2.8.1.3)						
8	<input type="radio"/> SETTLING OUT PRESS. (PSIG)						
9	<input type="radio"/> MIN. SEALING PRESSURE (PSIG)						
10	<input type="radio"/> TYPE BUFFER GAS, PRIMARY						
11	<input type="checkbox"/> PRESSURE (PSIG) (1-2.8.1.6)						
12	<input type="checkbox"/> FLOWRATE (LB/MIN)						
13	<input type="checkbox"/> FILTRATION						
14	<input type="radio"/> TYPE BUFFER GAS, SECONDARY						
15	<input type="checkbox"/> PRESSURE (PSIG) (1-2.8.1.6)						
16	<input type="checkbox"/> FLOWRATE (LB/MIN)						
17	<input type="checkbox"/> FILTRATION						
18	<input type="checkbox"/> FLOW RATE TO PROCESS						
19	<input type="radio"/> BUFFER GAS SYSTEM REQUIRED (2-2.8.1.5)						
20	<input type="radio"/> MANIFOLD (1-3.5.1.4)						
21	<input type="radio"/> METHOD OF CONTROL (1-2.8.1.5)						
22	<input type="radio"/> BUFFER GAS CONTROL SYSTEM SCHEMATIC BY VENDOR						
23	<input type="radio"/> PRESSURIZING GAS FOR SUBATMOSPHERIC SEALS (1-2.8.2.4)						
24	<input type="checkbox"/> SEAL MANUFACTURER _____						
25							
26	BEARING TEMPERATURE DETECTORS (2-3.4.7)						
27	<input type="radio"/> SEE ATTACHED API-670 DATASHEET						
28	<input type="radio"/> THERMOCOUPLES TYPE _____						
29	<input type="radio"/> RESISTANCE TEMP DETECTORS						
30	<input type="radio"/> RESISTANCE MAT'L _____ <input type="radio"/> _____ OHMS						
31	<input type="checkbox"/> ALARM TEMPERATURE (°F) _____						
32	<input type="checkbox"/> SHUTDOWN TEMPERATURE (°F) _____						
33	<input type="radio"/> PROVISION FOR LOCAL DISCONNECT (1-2.7.4.6)						
34	<input type="radio"/> LOCATION-JOURNAL BRG						
35	NO. _____ EA PAD _____ EVERY OTH PAD _____ PER BRG						
36	OTHER _____						
37	<input type="radio"/> LOCATION-THRUST BRG						
38	NO. _____ EA PAD _____ EVERY OTH PAD _____ PER BRG						
39	OTHER _____						
40	NO. (INACT) _____ EA PAD _____ EVERY OTH PAD _____ PER BRG						
41	OTHER _____						
42	<input type="radio"/> LOCAL DISCONNECTION (1-2.7.4.6)						
43	<input type="radio"/> MONITOR SUPPLIED BY (2-3.4.7.4)						
44	<input type="radio"/> LOCATION _____ ENCLOSURE _____						
45	<input type="radio"/> MFR. _____ <input type="checkbox"/> MODEL _____						
46	<input type="checkbox"/> SCALE RGE _____ ALARM <input type="checkbox"/> SET @ _____ °F						
47	<input type="radio"/> SHTDWN <input type="checkbox"/> SET @ _____ °F <input type="radio"/> TIME DELAY _____ SEC.						
48							
49	KEY PHASOR REQUIRED						
50	<input type="radio"/> COMPRESSOR <input type="radio"/> GEAR H.S. <input type="radio"/> GEAR L.S.						
		VIBRATION DETECTORS: <input type="radio"/> SEE ATTACHED API-670 DATA SHEET <input type="radio"/> TYPE _____ <input type="checkbox"/> MODEL _____ <input type="radio"/> MFR _____ <input type="radio"/> NO. AT EA SHAFT BEARING _____ TOTAL NO. _____ <input type="radio"/> OSCILLATOR-DETECTORS SUPPLIED BY <input type="radio"/> MFR _____ <input type="checkbox"/> MODEL _____ MONITOR SUPPLIED BY (2-3.4.7.2) <input type="radio"/> LOCATION _____ ENCLOSURE _____ <input type="radio"/> MFR. _____ <input type="checkbox"/> MODEL _____ <input type="checkbox"/> SCALE RGE _____ ALARM <input type="checkbox"/> SET @ _____ MILS <input type="radio"/> SHTDWN: <input type="checkbox"/> SET @ _____ MILS <input type="radio"/> TIME DELAY _____ SEC. <input type="radio"/> CASING VIBRATION TRANSDUCERS (2-3.4.7.5) <input type="radio"/> CASING VIBRATION MONITORS (2-3.4.7.6)					
		AXIAL POSITION DETECTOR: <input type="radio"/> SEE ATTACHED API-670 DATA SHEET <input type="radio"/> TYPE _____ <input type="checkbox"/> MODEL _____ <input type="radio"/> MFR _____ <input type="radio"/> NO. REQUIRED _____ <input type="radio"/> OSCILLATOR-DEMODULATOR SUPPLIED BY <input type="radio"/> MFR _____ <input type="checkbox"/> MODEL _____ MONITOR SUPPLIED BY (2-3.4.7.2) <input type="radio"/> LOCATION _____ ENCLOSURE _____ <input type="radio"/> MFR. _____ <input type="radio"/> ALARM <input type="checkbox"/> MODEL _____ <input type="checkbox"/> SCALE RGE _____ <input type="checkbox"/> SET @ _____ MILS <input type="radio"/> SHTDWN: <input type="checkbox"/> SET @ _____ MILS <input type="radio"/> TIME DELAY _____ SEC.					

INTEGRALLY GEARED COMPRESSOR DATA SHEET (API 617—7TH Chapter 3) U.S. CUSTOMARY UNITS		JOB NO. _____ ITEM NO. _____ REVISION NO. _____ DATE _____ PAGE <u>6</u> OF <u>8</u> BY _____				
1 CONSTRUCTION FEATURES, ROTOR BEARINGS (1 COLUMN PER ROTOR, USE ADDITIONAL SHEETS IF NEEDED)						
2 RADIAL BEARINGS, DRIVE END 3 <input type="checkbox"/> TYPE 4 <input type="checkbox"/> MANUFACTURER 5 <input type="checkbox"/> LENGTH (IN.) 6 <input type="checkbox"/> SHAFT DIA. (IN.) 7 <input type="checkbox"/> UNIT LOAD (ACT/ALLOW) 8 <input type="checkbox"/> BASE MATERIAL 9 <input type="checkbox"/> BABBIT THICKNESS (IN.) 10 <input type="checkbox"/> NO. PADS 11 <input type="checkbox"/> LOAD: BETWEEN/ON PAD 12 <input type="checkbox"/> PIVOT: CENTER/OFFSET, % 13 <input type="checkbox"/> RADIAL BEARING SPAN (IN.)	BULL GEAR	ROTOR 1	ROTOR 2	ROTOR 3	ROTOR 4	
14 RADIAL BRG, OPPOSITE DRIVE END 15 <input type="checkbox"/> TYPE 16 <input type="checkbox"/> MANUFACTURER 17 <input type="checkbox"/> LENGTH (IN.) 18 <input type="checkbox"/> SHAFT DIA. (IN.) 19 <input type="checkbox"/> UNIT LOAD (ACT/ALLOW) 20 <input type="checkbox"/> BASE MATERIAL 21 <input type="checkbox"/> BABBIT THICKNESS (IN.) 22 <input type="checkbox"/> NO. PADS 23 <input type="checkbox"/> LOAD: BETWEEN/ON PAD 24 <input type="checkbox"/> PIVOT: CENTER/OFFSET, %						
25 THRUST BEARINGS , ACTIVE 26 <input type="checkbox"/> TYPE 27 <input type="checkbox"/> MANUFACTURER 28 <input type="checkbox"/> UNIT LOADING (MAX PSI) 29 <input type="checkbox"/> UNIT LOAD (ULT.) (PSI) 30 <input type="checkbox"/> AREA (IN.) 31 <input type="checkbox"/> NO. PADS 32 <input type="checkbox"/> PIVOT: CENTER/OFFSET, % 33 <input type="checkbox"/> PAD BASE MATL 34 <input type="checkbox"/> COPPER BACKED? (2-2.7.3.7) 35 <input type="checkbox"/> COLLAR MATERIAL 36 <input type="checkbox"/> INTEGRAL OR REPLACEABLE COLLAR? 37 <input type="checkbox"/> SIZING CRITERIA (2-2.7.3.5) 38 <input type="checkbox"/> FLOODED OR DIRECTED LUBRICATION?						
39 THRUST BEARINGS , INACTIVE 40 <input type="checkbox"/> TYPE 41 <input type="checkbox"/> MANUFACTURER 42 <input type="checkbox"/> UNIT LOADING (MAX PSI) 43 <input type="checkbox"/> UNIT LOAD (ULT.) (PSI) 44 <input type="checkbox"/> AREA (IN.) 45 <input type="checkbox"/> NO. PADS 46 <input type="checkbox"/> PIVOT: CENTER/OFFSET, % 47 <input type="checkbox"/> PAD BASE MATL 48 <input type="checkbox"/> COPPER BACKED? (2-2.7.3.7) 49 <input type="checkbox"/> COLLAR MATERIAL 50 <input type="checkbox"/> INTEGRAL OR REPLACEABLE COLLAR? 51 <input type="checkbox"/> SIZING CRITERIA (2-2.7.3.5) 52 <input type="checkbox"/> FLOODED OR DIRECTED LUBRICATION?						

CENTRIFUGAL AND AXIAL COMPRESSOR DATA SHEET (API 617—7TH Chapter 3) U.S. CUSTOMARY UNITS			JOB NO. _____ ITEM NO. _____ REVISION NO. _____ DATE _____ PAGE <u>7</u> OF <u>8</u> BY _____		
1 <input type="checkbox"/> OTHER CONNECTIONS					
2 SERVICE:					
	NO.	SIZE	TYPE		NO. SIZE TYPE
3	LUBE-OIL INLET			PRESSURE	
4	LUBE OIL OUTLET			TEMPERATURE	
5	SEAL-OIL INLET			SOLVENT INJECTION	
6	SEAL-OIL OUTLET			PURGE FOR:	
7	SEAL GAS INLET			BRG. HOUSING	
8	SEAL GAS OUTLET			BTWN BRG & SEAL	
9	CASING DRAINS			BTWN SEAL & GAS	
10	STAGE DRAINS				
11 <input type="radio"/> INDIVIDUAL STAGE DRAINS REQUIRED (1-2.3.2.1.7) 12 <input type="radio"/> VALVED & BLINDED 13 <input type="radio"/> VALVED & BLINDED & MANIFOLD					
14 LUBRICATION AND SEALING SYSTEMS (1-2.10) (1-3.5.1.2)					
15 <input type="radio"/> SEE ATTACHED API 614 DATASHEET 16 <input type="radio"/> SEPARATE <input type="radio"/> COMBINED (2-2.10.1) 17 <input type="radio"/> INTEGRAL OIL RESERVOIR (1-3.3.2.11) 18 <input type="radio"/> OIL TYPE (2-2.10.2)					
19 ACCESSORIES					
20 COUPLING AND GUARDS (3.2) 21 NOTE: SEE ROTATING ELEMENTS—SHAFT ENDS 22 <input type="radio"/> SEE ATTACHED API-671 DATA SHEET <input type="radio"/> KEYLESS HYDRAULIC <input type="radio"/> KEYED <input type="radio"/> FLANGED <input type="radio"/> OTHER _____ 23 COUPLING FURNISHED BY _____ 24 MANUFACTURER _____ TYPE _____ MODEL _____ 25 COUPLING GUARD FURNISHED BY: _____ 26 TYPE: <input type="radio"/> FULLY ENCLOSED <input type="radio"/> SEMI-OPEN <input type="radio"/> OTHER					
27 COUPLING DETAILS 28 <input type="checkbox"/> MAX O.D. _____ IN. 29 <input type="checkbox"/> HUB WEIGHT _____ LB. 30 <input type="checkbox"/> SPACER LENGTH _____ IN. 31 <input type="checkbox"/> SPACER WEIGHT _____ LB.			32 <input type="radio"/> PLUG AND RING GAUGES (1-3.2.5) LUBRICATION REQUIREMENTS: <input type="radio"/> NON-LUBE <input type="radio"/> CONT. OIL LUBE <input type="radio"/> OTHER _____ QUANTITY PER HUB _____ GPM		
33 MOUNTING PLATES (1-3.3)					
34 <input type="radio"/> BASEPLATES FURNISHED BY (1-3.3.2.1) 35 <input type="radio"/> COMPRESSOR ONLY <input type="radio"/> DRIVER <input type="radio"/> GEAR 36 <input type="radio"/> OTHER _____ 37 <input type="radio"/> NONSKID DECKING (1-3.3.2.4) <input type="radio"/> SLOPED DECK (1-3.3.2.4.1) 38 <input type="checkbox"/> LEVELING PADS OR TARGETS (1-3.3.2.6) 39 <input type="checkbox"/> COLUMN MOUNTING (1-3.3.2.5) 40 <input type="radio"/> SUB-SOLE PLATES REQUIRED (1-3.3.2.10) 41 <input type="checkbox"/> STAINLESS STEEL SHIM THICKNESS _____ IN. 42 <input type="radio"/> MACHINED MOUNTING PADS REQUIRED (1-3.3.2.9)			43 <input type="radio"/> SOLEPLATES FURNISHED BY (1-3.3.3.1) <input type="checkbox"/> THICKNESS _____ IN. <input type="radio"/> SUBSOLE PLATES REQUIRED (1-3.3.3.1.5) <input type="checkbox"/> STAINLESS STEEL SHIM THICKNESS _____ IN. <input type="radio"/> COMPRESSOR _____ <input type="radio"/> COUNTER BORE ANCHOR BOLT HOLES (1-3.3.3.1.2)		
44 MATERIALS INSPECTION REQUIREMENTS (1-4.2.2.1)					
45 <input type="radio"/> RADIOGRAPHY REQUIRED FOR _____ 46 <input type="radio"/> ULTRASONIC REQUIRED FOR _____ 47 <input type="radio"/> MAGNETIC PARTICLE REQUIRED FOR _____ 48 <input type="radio"/> LIQUID PENETRANT REQUIRED FOR _____			49 <input type="radio"/> LOW TEMPERATURE (1-2.2.1.15.2) _____ MIN. DESIGN METAL TEMPERATURE (°F) _____ AT CONCURRENT PRESSURE (PSIG) _____ <input type="radio"/> OTHER TRAIN COMPONENTS (1-2.2.1.15.2) _____ <input type="radio"/> Q.C. OF INACCESSIBLE WELDS (1-2.3.1.11.2) _____		

ANNEX 3B
INTEGRALLY GEARED COMPRESSOR VENDOR
DRAWING AND DATA REQUIREMENTS

**API STANDARD 617
CHAPTER 3 ANNEX B
VENDOR DRAWING AND
DATA REQUIREMENTS**

JOB NO. _____ ITEM NO. _____
PURCHASE ORDER NO. _____ DATE _____
REQUISITION NO. _____ DATE _____
INQUIRY NO. _____ DATE _____
PAGE _____ OF _____ BY _____
REVISION _____
UNIT _____
NO. REQUIRED _____

FOR _____
SITE _____
SERVICE _____

Proposal^a Bidder shall furnish _____ copies of data for all items indicated by an X.

Review^b Vendor shall furnish _____ copies and _____ transparencies of drawings and data indicated.

Final^c Vendor shall furnish _____ copies and _____ transparencies of drawings and data indicated.
Vendor shall furnish _____ operating and maintenance manuals.

**DISTRIBUTION
RECORD**

Final—Received from vendor _____
Final—Due from vendor^c _____
Review—Returned to vendor _____
Review—Received from vendor _____
Review—Due from vendor^c _____

DESCRIPTION

		<ol style="list-style-type: none"> 1. Certified dimensional outline drawing and list of connections 2. Cross-sectional drawings and part numbers 3. Rotor assembly drawings and part numbers 4. Thrust-bearing assembly drawings and part numbers 5. Journal-bearing assembly drawings and bill of materials 6. Coupling assembly drawings and bill of materials 7. Lube-oil schematic and bill of materials 8. Lube-oil arrangement drawing and list of connections 9. Lube-oil component drawings and data 10. Seal system schematic and bill of material 11. Seal system arrangement drawing and list of connections 12. Seal system component drawings and data 13. Seal assembly drawing and part numbers 14. Electrical and instrumentation schematics and bill of materials 15. Electrical and instrumentation arrangement of drawing and list of connections 16. Buffer gas system schematic and bill of material 17. Buffer gas system arrangement drawing and list of connections 18. Buffer gas system component drawing and data 19. Data sheets (proposal/as-built) 20. Allowable external forces and moments for each nozzle in tabular form(with proposal) 21. Gas quality documentations 22. Gear tooth contact check results 23. Certificates for gear materials 24. Predicted noise sound level (proposal) 25. Metallurgy of major components (in proposal) 26. Lateral analysis report 27. Torsional analysis report 28. Vibration analysis report 					
--	--	---	--	--	--	--	--

^aProposal drawings and data do not have to be certified or as-built.
^bPurchaser will indicate in this column the desired time frame for submission of materials, using the nomenclature given at the end of this form.
^cBidder shall complete this column to reflect his actual distribution schedule and include this form with his proposal.
^dThese items are normally provided only in instrumentation manuals.
^eIf furnished by the vendor.
^fIf specified.

**API STANDARD 617
CHAPTER 3 ANNEX B
VENDOR DRAWING AND
DATA REQUIREMENTS**

JOB NO. _____ ITEM NO. _____
PAGE _____ OF _____ BY _____
DATE _____ REVISION _____

Proposal^a Bidder shall furnish _____ copies of data for all items indicated by an X.

Review^b Vendor shall furnish _____ copies and _____ transparencies of drawings and data indicated.

Final^c Vendor shall furnish _____ copies and _____ transparencies of drawings and data indicated.
Vendor shall furnish _____ operating and maintenance manuals.

**DISTRIBUTION
RECORD**

Final—Received from vendor _____
Final—Due from vendor^c _____
Review—Returned to vendor _____
Review—Received from vendor _____
Review—Due from vendor^c _____

DESCRIPTION

			29.	Performance curves for each compressor section (proposal/as-built)						
			30.	Impeller overspeed test report						
			31.	Mechanical running test report						
			32.	Coupling selection and rating						
			33.	List of recommended spare parts						
			34.	List of special tools						
			35.	Preparation for storage at job site before installation						
			36.	Weather protection and winterization required at job site						
			37.	Tabulation of all utilities						
			38.	List of similar machines						
			39.	Operating restrictions to protect equipment during start-up operation and shutdown						
			40.	List of components requiring purchaser's approval						
			41.	Summary of materials and hardness of materials exposed to H ₂ S						
			42.	Seal leakage rates						
			43.	Interstage cooler system data						
			44.	Drawings, details and description of instrumentation and controls						
			45.	Minimum length of straight pipe required at machine inlet or side inlets						
			46.	Maximum and minimum allowable seal pressure for each compressor						
			47.	Statement of manufacturer's testing capabilities						
			48.	Performance test data and curves						
			49.	Back-to-back impeller machine vendor to provide thrust-bearing loads versus differential pressure curve						
			50.	Balance piston leakage rates						
			51.	When specified, vendor shall supply curves of balance piston line differential pressure versus thrust load						
			52.	Production delivery schedule						
			53.	Testing procedures						
			54.	Progress reports						
			55.	Installation manual						
			56.	Operating and maintenance manual						
			57.	Technical data manual						

^aProposal drawings and data do not have to be certified or as-built.

^bPurchaser will indicate in this column the desired time frame for submission of materials, using the nomenclature given at the end of this form.

^cBidder shall complete this column to reflect his actual distribution schedule and include this form with his proposal.

^dThese items are normally provided only in instruction manuals.

^eIf furnished by the vendor.

^fIf specified.

**API STANDARD 617
CHAPTER 3 ANNEX B
VENDOR DRAWING AND
DATA REQUIREMENTS**

JOB NO. _____ ITEM NO. _____
PAGE _____ OF _____ BY _____
DATE _____ REVISION _____

Notes:

1. Where necessary to meet the scheduled shipping date, the vendor shall proceed with manufacture upon receipt of the order and without awaiting the purchaser's approval of drawings.
2. The vendor shall send all drawings and data to the following:

-
3. All drawings and data shall show project, purchase order, and item numbers as well as plant location and unit. One set of the drawings and instructions necessary for field installation, in addition to the copies specified above, shall be forwarded with shipment.
 4. See the descriptions of required items that follow.
 5. All of the information indicated on the distribution schedule shall be received before final payment is made.
 6. If typical drawings, schematics, bills of material are used for proposals, they shall be marked-up to show the expected weight and dimensions to reflect the actual equipment and scope proposed.

Nomenclature:

- S—number of weeks before shipment.
- F—number of weeks after firm order.
- D—number of weeks after receipt of approved drawings.

Vendor _____

Date _____ Vendor Reference _____

Signature _____

(Signature acknowledges receipt of all instructions)



**API STANDARD 617
CHAPTER 3 ANNEX B
VENDOR DRAWING AND
DATA REQUIREMENTS**

JOB NO. _____ ITEM NO. _____
PAGE _____ OF _____ BY _____
DATE _____ REVISION _____

DESCRIPTION

1. Certified dimensional outline drawing and list of connections including the following:
 - a. The size, rating and location of all customer connections.
 - b. Approximate overall and handling weights.
 - c. Overall dimensions and maintenance and dismantling clearances.
 - d. Shaft centering height.
 - e. Dimensions of base plate (if furnished) for train or skid mounted package, complete with diameters, number and locations of bolt holes and thicknesses of sections through which the bolts must pass.
 - f. Grounding details.
 - g. Forces and moments allowed for suction and discharge nozzles.
 - h. Center of gravity and lifting points.
 - i. Shaft end separation and alignment data.
 - j. Direction of rotation.
 - k. Winterization, tropicalization and/or noise attenuation details, when required.
 - l. Sketches to show lifting of assembled machine and major components and auxiliaries.
2. Cross-sectional drawings and part numbers of major equipment.
3. Rotor assembly drawings and part numbers.
4. Thrust-bearing assembly drawings and part numbers.
5. Journal-bearing assembly drawings and bill of materials.
6. Coupling assembly drawing and bill of materials.
7. Lube-oil schematic and bill of material including the following:
 - a. Oil flows, temperatures and pressure at each point.
 - b. Control alarm shutdown settings for pressure and temperature.
 - c. Total heat loads.
 - d. Utility requirements including electrical, water, air and steam.
 - e. Pipe, valve and orifice sizes.
 - f. Instrumentation, safety devices, control schemes and wiring diagrams.
8. Lube-oil arrangement drawing and list of connections.
9. Lube-oil component drawings and data including the following:
 - a. Pumps and drivers.
 - b. Coolers, filter and reservoir.
 - c. Instrumentation.
10. Seal system schematic and bill of material including the following:
 - a. Flows oil or gas, temperatures and pressures at each point.
 - b. Control, alarm and shutdown settings for pressure and temperatures.
 - c. Total heat load for coolers, if required.
 - d. Utility requirements including electrical, water, air and steam.
 - e. Pipe, valve and orifice sizes.
 - f. Instrumentation, safety devices, control schemes and wiring diagrams.
 - g. Filtration requirements.
 - h. Height of overhead tank above centerline of machine.
11. Seal system arrangement drawing and list of connections.

**API STANDARD 617
CHAPTER 3 ANNEX B
VENDOR DRAWING AND
DATA REQUIREMENTS**

JOB NO. _____ ITEM NO. _____
PAGE _____ OF _____ BY _____
DATE _____ REVISION _____

12. Seal system components drawing and data, including the following:
 - a. Pumps and drivers.
 - b. Coolers, filter and reservoirs.
 - c. Instrumentation.
13. Seal assembly drawing and part numbers.
14. Electrical and instrumentation arrangement drawing and list of connections.
 - a. Vibration warning and shutdown limits.
 - b. Bearing temperature warning and shutdown limits.
 - c. Lube-oil temperature warning and shutdown limits.
 - d. Lube-oil pressure warning and shutdown limits.
 - e. Lube-oil level warning and shutdown limits.
 - f. Machine discharge pressure and temperature warning and shutdown limits.
 - g. Seal, pressure, temperature, flow warning and shutdown limits.
15. Electrical and instrumentation arrangement drawing and list of connections.
16. Buffer gas system schematic and bill of material.
17. Buffer gas system schematic and bill of material.
18. Buffer gas system component drawings and data, including the following:
 - a. Control devices.
 - b. Pressure and filtration requirements.
19. Data sheets provided with proposal as-built.
20. Vendor shall furnish the allowable forces and moments for each nozzle in tabular form with the proposal.
21. The vendor shall provide documentation showing the gear has met the quality levels of ISO 1328, Grade 4I.
22. The vendor shall make available to the purchaser the results of the gear tooth contact check for each gear set installed in the job gear box.
23. Certificates for gearing materials:
 - a. Mill test reports for all gear element components.
 - b. UT of all gear element components after rough machining.
 - c. Record of all heat treatment and resulting hardness, versus case depth of all welds on rotating elements.
 - d. MP of gear and pinion teeth.
 - e. Results of quality control checks.
 - f. Gear tooth surface finish.
 - g. Plating of teeth.
 - h. Tooth profile, helix deviation pitch error, and cumulative pitch error.
 - i. Contact checks in job casing.
 - j. Records of all radiographs and UT.
 - k. Hardness versus case depth.
24. Predicted noise level, sound pressure, and sound power level.
25. Metallurgy of major components identified with ASTM, AISI, ASME, or SAE numbers stated in proposal.
26. Lateral analysis report when specified shall also include a stability analysis.
27. Torsional analysis report.
28. Vibration analysis conducted on machines that require disassembly after balancing to allow machine assembly. The vendor shall also provide historic unbalance data for the machine size and type.
29. Performance data and curves, sufficient performance data to enable the purchaser to properly design a control system and surge prevention.

**API STANDARD 617
CHAPTER 3 ANNEX B
VENDOR DRAWING AND
DATA REQUIREMENTS**

JOB NO. _____ ITEM NO. _____
PAGE _____ OF _____ BY _____
DATE _____ REVISION _____

30. Dimensions taken from each impeller before and after overspeed testing shall be submitted for review.
31. Mechanical running test report to include the following:
 - a. Unfiltered vibration.
 - b. Plots showing synchronous vibration and phase angle, filtered and unfiltered.
 - c. When specified, data shall be furnished in polar form.
 - d. When specified, tape recordings shall be made of all real time vibration data.
 - e. Electrical and mechanical runout at each probe.

Immediately upon completion of each witnessed mechanical or performance test, copies of the log and data recorded during the test shall be given to the witnesses.
32. Coupling selection and rating.
33. List of spare parts recommended for start-up and normal maintenance purposes.
34. List of the special tools furnished for maintenance.
35. The vendor shall provide the purchaser with instructions necessary to preserve the integrity of the storage preparation after the equipment arrives at the job site and before start-up.
36. A description of any special weather protection required for start-up, operation and period of idleness under the site conditions specified on the data sheets.
37. A complete list of utility requirements: quantity, filtration and supply pressure of the following:
 - a. Steam.
 - b. Water.
 - c. Electricity.
 - d. Air.
 - e. Gas.
 - f. Lube oil and seal oil (quantity and supply pressure).
 - g. Heat loads.
 - h. Power ratings and operating power requirements for auxiliary drivers.
38. A list of machines similar to the proposed machines that have been installed and operating under conditions analogous to those specified in the inquiry.
39. Any start-up, shutdown or operating restrictions required to protect the integrity of the equipment, including any unacceptable speeds due to natural frequencies.
40. A list of any components that can be construed as being of alternative design, requiring purchaser's acceptance.
41. A summary of the materials of construction for the compressor, including hardness for materials exposed to H₂S.
42. The maximum seal gas rates (injection or eduction) and rated or expected inner seal-oil leakage rates, if applicable. When self-acting dry gas seals are supplied, expected seal gas consumption, minimum seal gas supply flow and primary vent flow should be given at maximum sealing pressure and at conditions over the operating envelope of the machine.
43. When interstage coolers are furnished, the vendor shall provide the following:
 - a. Drawing showing cooling system details.
 - b. Data for purchaser's heat and material balances.
 - c. Details of provisions for separating and withdrawing condensate.
 - d. Vendor's recommendations regarding provision for support and piping expansion.
44. Drawings, details and descriptions of the operations of instrumentation and controls as well as the makes, materials and type of auxiliary equipment. The vendor shall also include a complete description of the alarm and shutdown facilities to be provided.

**API STANDARD 617
CHAPTER 3 ANNEX B
VENDOR DRAWING AND
DATA REQUIREMENTS**

JOB NO. _____ ITEM NO. _____
PAGE _____ OF _____ BY _____
DATE _____ REVISION _____

45. The minimum length of straight pipe required for proper flow characteristics at the inlet and at any side inlet connection.
46. Maximum and minimum allowable seal pressure for each compressor.
47. A statement of the manufacturers capability regarding testing (including performance testing) of the compressor and any other specified items on the train. Details of each optional test specified shall be included.
48. Performance curves shall be submitted for each section (between purchasers process nozzles) of each casing as well as an overall curve for the train. All curves submitted prior to complete performance testing shall be marked "predicted." Any set of curves resulting from a test shall be marked "tested."
If a performance test is specified, the vendor shall provide test data and curves when the test has been completed. The surge points shall be shown on the performance curves.
49. For compressors that have a back-to-back impeller arrangement, the vendor shall furnish a curve showing the expected loading on the active or inactive side of the thrust bearing versus any combination of differential pressures across the low pressure and high pressure sections of the casing.
50. The vendor shall supply balance piston leakage based on design clearances and twice design clearances for the rated conditions.
51. When specified, the vendor shall supply curves of balance piston line differential pressure versus thrust load.
52. The vendor shall provide productions and delivery schedules.
53. The vendor shall submit detailed procedures, including acceptance criteria for the mechanical running test and all optional test, at least 6 weeks before the first running test.
54. The vendor shall submit progress reports.
55. All information required for the proper installation of the equipment shall be compiled in a manual that must be issued no later than the time of final certified drawings.
56. A manual containing all required operating and maintenance instructions shall be supplied not later than 2 weeks after all specified test shall have been successfully completed.
57. The vendor shall provide a "technical data manual within 30 days of completion" of shop testing including the following:
 - a. Necessary certification of materials.
 - b. Purchase specification for all items on the bill of materials.
 - c. Test data to verify requirements of specifications have been met.
 - d. Heat treat records.
 - e. Results of quality test and inspections.
 - f. Mechanical running test data log.
 - g. Final assembly maintenance and running clearances.

The vendor is also required to keep this data available for examination by the purchaser upon request, for at least 5 years.

ANNEX 3C
INTEGRALLY GEARED COMPRESSOR NOMENCLATURE
(NORMATIVE)

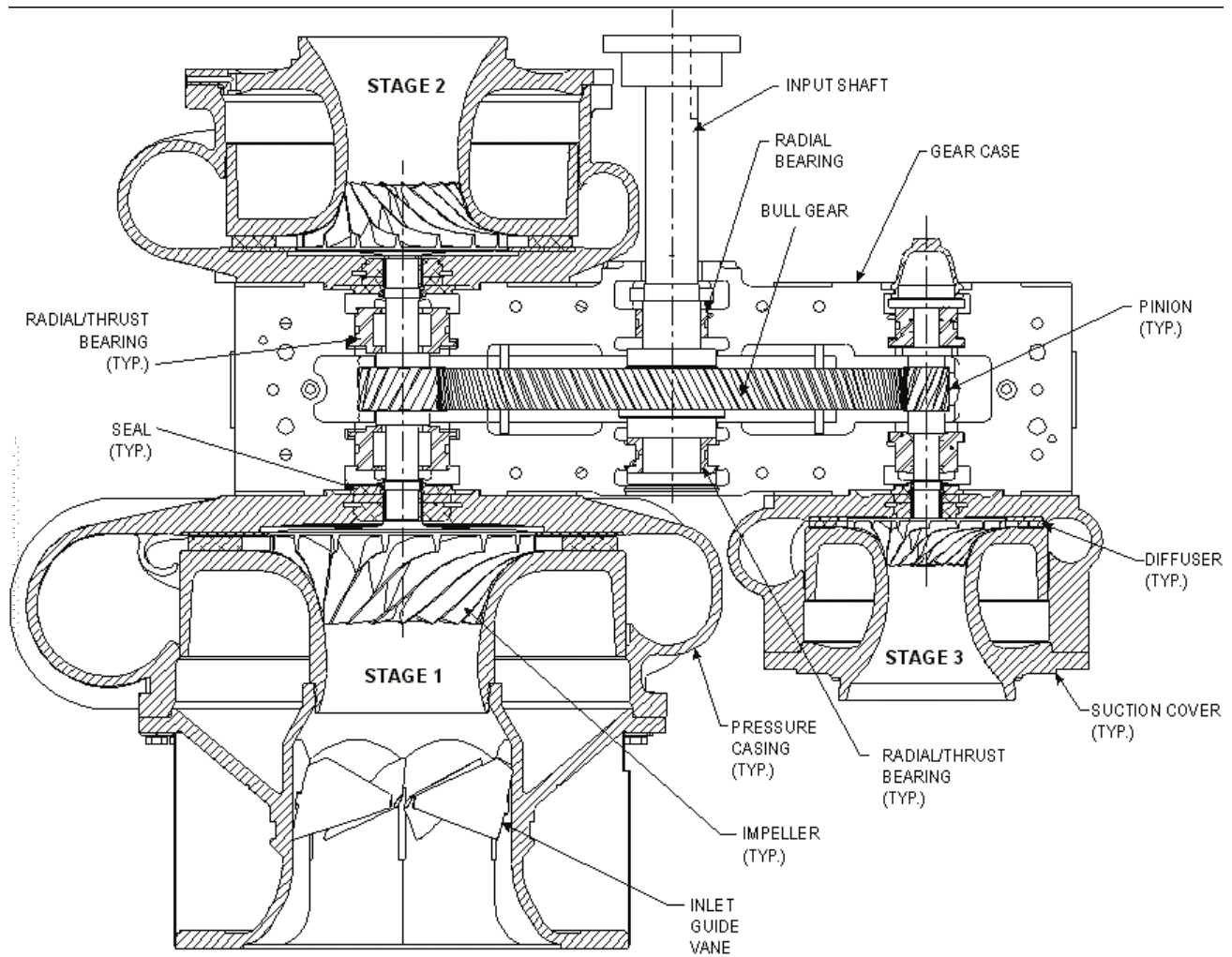

Figure 3.C-1—Typically Integrally Geared Compressor Showing Nomenclature of Key Parts

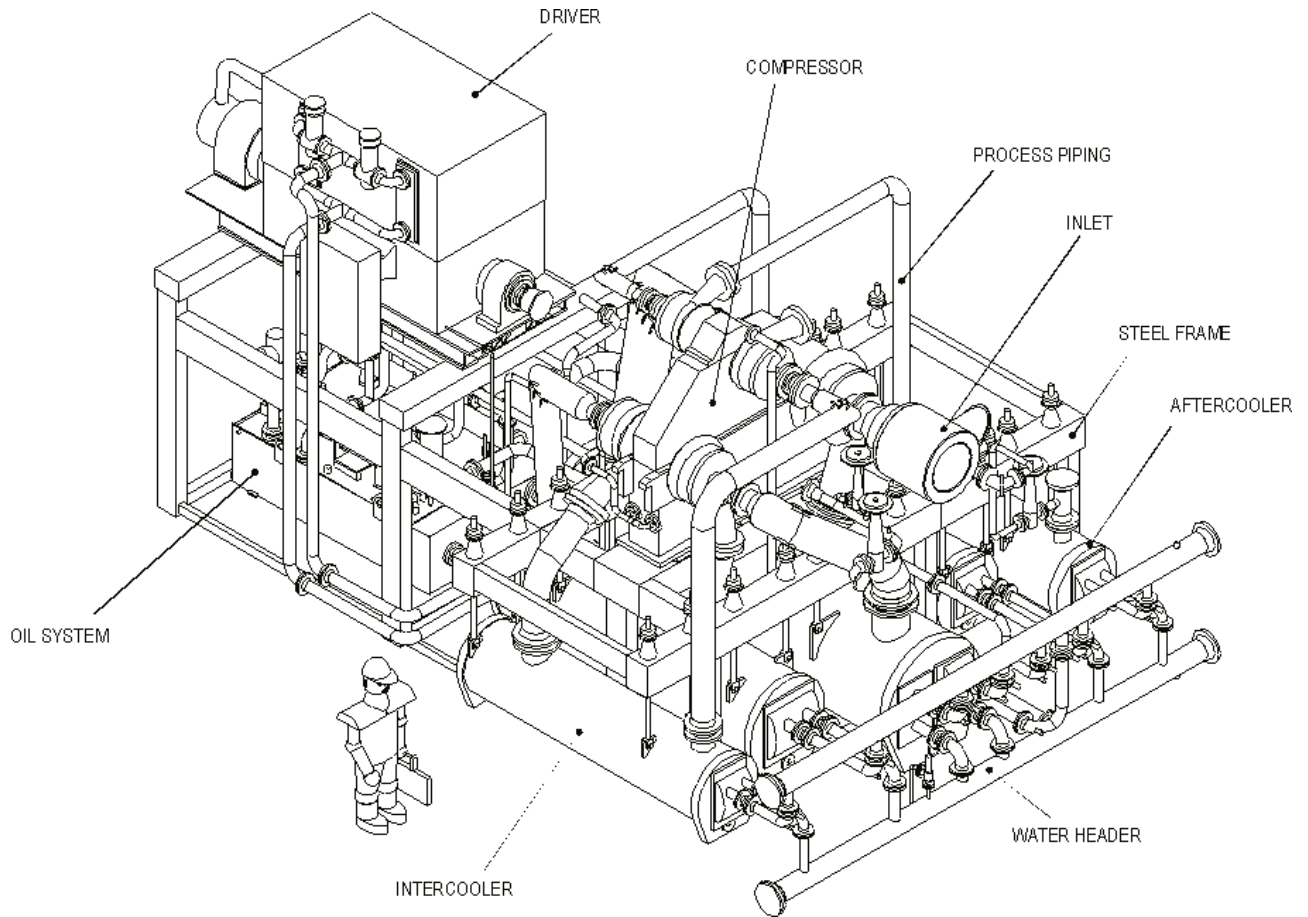

Figure 3.C-2—Typically Integrally Geared Compressor Arrangement Showing Nomenclature of Key Elements

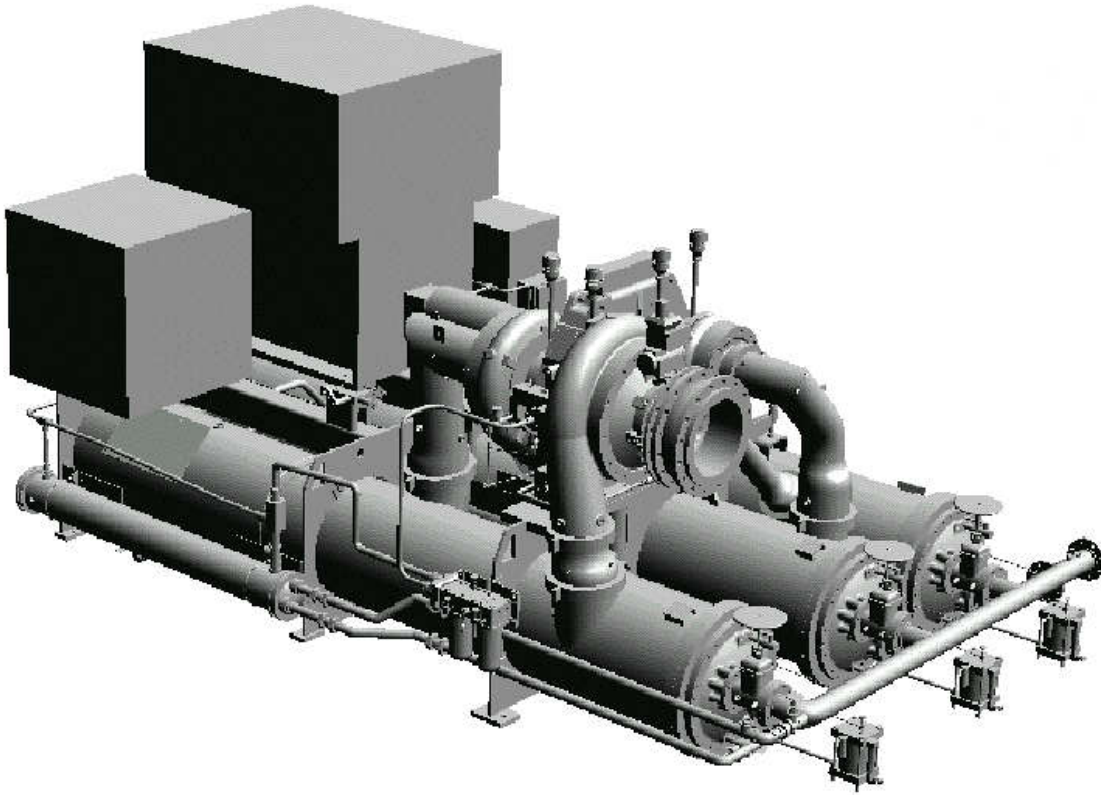

Figure 3.C-3—Typically Integrally Geared Compressor Arrangement

**ANNEX 3D
INSPECTOR'S CHECK LIST**

Item	Standard 617		Reviewed	Observed	Witnessed	Inspected By	Status
	Par	Ch					
GENERAL							
Contract Review—Testing and Inspections Listed in Proposal	2.2.1.4	1					
General Test Requirements	4.1.1 4.1.3 4.1.4 4.1.4.1 4.1.6 4.1.7 4.2.1 4.2.1.2	1 1 1 1 1 1 1 1					
Cleanliness	4.2.1.3 4.2.1.4	1 1					
Hardness	4.2.1.5	1					
Nameplate	2.11.1 2.11.2 2.11.2.1	3 3 3					
Rotation Arrows	2.11.3	3					
MATERIAL INSPECTIONS							
Material Inspections	4.2.2.1	1					
Castings	2.2.2.1	1					
Low Temperature Impact	2.2.1.15.5	1					
Forgings	2.2.3.2	1					
Weldings	2.2.4.1	1					
Pressure-containing Casings	2.3.1	1					
Material Inspection of Pressure-containing Parts	2.3.1.12	1					
ROTATING ELEMENT							
Impellers	2.5.10.4 2.5.10.5 2.5.10.6 4.3.3.1	1 1 1 1					
Overspeed	2.5.10.7 4.3.3.1	1 1					
Balance	2.6.8 2.6.8.8 Annex B	1 1					
Run-out	2.6.8.9 2.6.8.10	1 1					
ACCESSORIES							
Shaft End Seals	4.3.5 Annex D	1					
Lubrication and Sealing Systems	2.10.3 API Std 614	1					
Drivers	3.1	1					
Steam Turbine	3.1.4 API Std 612	1					
Motor	3.1.5 API Std 541	1					
Gas Turbine	3.1.7 API Std 616	1					
Separate Gear Units	3.1.8 API Std 613	1					
Coupling and Guard	3.2 API Std 671	1					

Item	Standard 617		Reviewed	Observed	Witnessed	Inspected By	Status
	Par	Ch					
Instrumentation	3.4.3 3.4.4 API Std 614 API Std 670	1 1					
Alarms and Shutdowns	3.4.5 API Std 614	1					
Electrical Systems	3.4.6 API Std 614 2.1.14	1 1					
Piping	3.5.1 API Std 614	1					
Special Tools	3.6.1 3.6.2	1 1					
HYDROSTATIC TEST							
Hydrostatic Test	4.3.2.1 4.3.2.2 4.3.2.3	1 1 1					
OVERSPEED TEST							
Impeller Overspeed Test	4.3.3.1	1					
MECHANICAL RUNNING TEST							
Unbalance Response Verification	2.6.3.1	1					
Vibration Record	2.6.3.1.1 4.3.6.1.1 4.3.6.1.2 4.3.6.1.3	1 1 1 1					
Contract Shaft Seals Used in Test	4.3.6.1.4 4.3.1.1.1	1 3					
Oil Flow Rates P. & T.	4.3.1.1.3	3					
Oil System Clean	4.3.1.1.4	3					
Warning Protective Control Devices Checked	4.3.1.1.6	3					
Connections Check for Leaks	4.3.1.1.5	3					
Test Coupling Used	4.3.1.1.8	3					
Vibration Levels	4.3.1.1.11	3					
Test Speeds Performed	4.3.1.2.1	3					
Test Run at Trip Speed	4.3.1.2.2	3					
4-hour Test Run	4.3.1.2.3	3					
Seal Flow Data	4.3.1.2.4	3					
Lube and Seal Oil Flows Varied	4.3.6.1.5	1					
Vibration Levels	4.3.1.3.1 4.3.1.3.2 4.3.1.3.3	3 3 3					
Lateral Critical Speed Verified	4.3.1.3.3	2					
Unbalance Response Analysis Verified	4.3.1.3.5 4.3.1.3.6	3 3					
Spare Rotor Tested	4.3.1.4.2	3					
Assembled Compressor Gas Leak	4.3.2 4.3.2.1 4.3.2.2 4.3.2.3	3 3 3 3					
OPTIONAL TESTING							
Performance Test	4.3.3.1 4.3.3.1.1 4.3.3.1.2 4.3.3.1.3 4.3.3.1.4 4.3.3.1.5	3 3 3 3 3 3					

Item	Standard 617		Reviewed	Observed	Witnessed	Inspected By	Status
	Par	Ch					
Complete Test Unit	4.3.3.2	3					
Gear Test—Stand Alone	4.3.3.3	3					
Full-speed Test	4.3.1.2.3	3					
Helium Test	4.3.8.2	1					
Sound-level Test	4.3.8.3	1					
Auxiliary Equipment Test	4.3.8.4	1					
Post-test Inspection of Compressor Internal	4.3.8.5	1					
Full-pressure/Full-load/Full-speed Test	4.3.8.6	1					
Post-test Inspection of Hydraulic Coupling Fit	4.3.8.7	1					
Spare Parts Test	4.3.8.8	1					
PREPARATION FOR SHIPMENT							
Equipment Prepared	4.4.1	1					
	4.4.2	1					
Paint	4.4.3.1	1					
Exterior Machined Surfaces Coated	4.4.3.2	1					
Bearing Housings, Oil Systems, Auxiliary Equipment and Piping Preserved	4.4.3.4	1					
Openings Covered and Protected	4.4.3.5	1					
	4.4.3.6	1					
	4.4.3.7	1					
Lifting Points Identified	4.4.3.8	1					
Equipment Identified, Tagged, Packing List	4.4.3.9	1					
Spare Rotor Prepared for Storage	4.4.3.10	1					
Exposed Shafts, etc. Prepared for Shipment	4.4.3.12	1					
Auxiliary Piping Connections Tagged or Stamped	4.4.4	1					
	4.4.5	1					
Installation, Instructions Shipped with Equipment	4.4.6	1					
Gear Contact Checks	4.2.1	3					
	4.2.1.1	3					
	4.2.1.2	3					
Tooth Mesh Inspection	4.3.1.4.1	3					

ANNEX 3E
EXTERNAL FORCES AND MOMENTS

For integrally geared compressors, it is not possible to give a formula to calculate the maximum allowable piping forces and moments on each casing flange. The limiting criteria are the gear contact pattern and the impeller/stator gap. The maximum value of the external forces and moments, which leads to acceptable deformations and therefore acceptable changes of the gear contact pattern and the impeller/stator gap, depends on various parameters.

These parameters include:

Volute geometry, volute wall thickness, length of overhang,

gear case geometry and gear case wall thickness. The possible combinations are nearly endless.

Each manufacturer has limits based on his own experience for each volute size and gear case combination for a given specific machine. The values are available from the manufacturer with the quotation.

It is a common practice on integrally geared compressors to supply expansion joints in order to minimize the piping loads on the machine flanges and to insure that piping loads are within the allowable limits for the particular unit.

**ANNEX 3F
RATING FORMULAS FOR INTEGRALLY
GEARED COMPRESSOR GEARING**

The rating formula's given below are based on the methods from AGMA 2101. The constant of 0.8 at the beginning of the formulas below is to provide increased reliability.

F.1 Pitting Resistance Power Rating

The pitting resistance allowable transmitted power, P_{az} , for a gear set is:

$$P_{az} = 0.8 \left(\frac{\omega_1 b}{1.91 \times 10^7} \right) \left(\frac{Z_I}{K_V K_H C_{SF}} \right) \left(\frac{d_{w1} \sigma_{HP} Z_N}{Z_E} \right)^2 \quad (3.F-1)$$

where

ω_1 = pinion speed (rpm),

b = face width (mm),

d_{w1} = operating pitch diameter of pinion (mm) = $2a/(u - 1)$,

a = center distance (mm),

u = gear tooth ratio (never less than 1.0),

Z_E = elastic coefficient = 190 for steel pinion and gear,

Z_I = geometry factor (reference AGMA 908).

F.2 Bending Strength Power Rating

The bending strength allowable transmitted power, P_{ay} , for a gear pair is:

$$P_{ay} = 0.8 \left(\frac{\omega_1 d_{w1}}{1.91 \times 10^7} \right) \left(\frac{b m_t Y_J \sigma_{FF} Y_N}{K_V K_H K_{SF}} \right) \quad (3.F-2)$$

where

m_t = transverse module (equal to normal module divided by the cosine of the helix angle at the standard pitch diameter),

Y_J = geometry Factor (reference AGMA 908).

F.3 Load Distribution Factor, K_H

If the value of K_H calculated below is less than 1.1, then 1.1 shall be used as the value of K_H . Gear designs shall not result in a calculated value of K_H over 1.50 without approval from the purchaser.

$$K_H = 1.0 + 0.8 (K_{Hpf} + 0.054 + 0.4032 \times 10^{-3} b - 1.152 \times 10^{-7} b^2) \quad (3.F-3)$$

where

b = face width of narrower member of gear set (mm)

$K_{Hpf} = \text{bod} - 0.025$

when $b \leq 25$ mm

= $\text{bod} - 0.0375 + 0.000492 b$

when $25 < b < 432$

= $\text{bod} - 0.1109 + 0.000815 b - 3.53 \times 10^{-7} b^2$

when $432 < b \leq 1020$

bod = the greater of 0.05 or $b/(10 d_{w1})$

Note: The distance from the center of the gear mesh to the center of the bearing span divided by the bearing span must be less than 0.175. The tooth contact must be checked at assembly, with contact adjustments as required. If these conditions are not met, or for wide face gears, an analytical approach may be used to determine a more conservative load distribution factor, with prior approval by the purchaser.

F.4 Dynamic Factor, K_V

ISO 1328 Grade 5 => $K_V = 1.135$

ISO 1328 Grade 4 => $K_V = 1.120$

ISO 1328 Grade 3 => $K_V = 1.105$

ISO 1328 Grade 2 => $K_V = 1.090$

The dynamic factor, K_V , does not account for dynamic tooth loads that may occur due to torsional or lateral natural frequencies. System designs should avoid having such natural frequencies close to an excitation frequency associated with an operating speed since the resulting gear tooth dynamic loads may be very high.

F.5 Stress Cycle Factors, Z_N and Y_N

$Z_N = 2.466 N^{-0.056}$, pitting stress cycle (life) factor,

$Y_N = 1.6831 N^{-0.0323}$, bending stress cycle (life) factor.

N is the number of stress cycles,

N = pinion RPM 1.052×10^7 for the pinion,

N = bull gear RPM $\times 1.052 \times 10^7 \times$ number of pinions in mesh for the bull gear.

Note: These factors are based on the lower line in Figures 17 and 18 of ANSI/AGMA 2101-C95 with 175,316 hours (20 years \times 365.242 days/year \times 24 hours/day) of continuous service at rated operating speed.

F.6 Allowable Stress Numbers, σ_{HP} and σ_{FP}

The values of σ_{HP} and σ_{FP} shall be for Grade 2 materials per ANSI/AGMA 2101-C95, Clause 16.

F.7 Reverse Loading

For idler gears and other gears where the teeth are completely reverse loaded on every cycle, use 70% of the allowable bending stress number, σ_{FB} in ANSI/AGMA 2101-C95.

F.8 Service Factor, C_{SF} and K_{SF}

The service factor used for integrally geared centrifugal compressors shall be 1.4 when driven by an induction motor, 1.6 when driven by a gas or steam turbine, and 1.7 when driven by a synchronous motor or internal combustion engine.

Chapter 4

Expander-compressors

.....

CONTENTS

	Page
SECTION 1—GENERAL	4-1
1.1 Scope	4-1
1.2 Definition of Terms	4-1
SECTION 2—BASIC DESIGN	4-1
2.1 General	4-1
2.2 Materials	4-1
2.3 Casings	4-1
2.4 Inlet Guide Vanes, Variable Nozzles, and Heat Shields	4-2
2.5 Rotating Elements	4-2
2.6 Dynamics	4-4
2.7 Bearings and Bearing Housings	4-5
2.8 Expander-compressor Shaft Seals	4-5
2.9 Gears	4-5
2.10 Lubrication and Sealing Systems	4-6
2.11 Nameplates and Rotation Arrows	4-6
SECTION 3—ACCESSORIES	4-6
3.1 Drivers	4-6
3.2 Couplings and Guards	4-6
3.3 Mounting Plates	4-6
3.4 Controls and Instrumentation	4-6
3.5 Piping and Appurtenances	4-8
3.6 Special Tools	4-8
SECTION 4—INSPECTION, TESTING, AND PREPARATION FOR SHIPMENT ...	4-8
4.1 General	4-8
4.2 Inspection	4-8
4.3 Testing	4-8
4.4 Preparation for Shipment	4-10
SECTION 5—VENDOR'S DATA	4-11
5.1 General	4-11
5.2 Proposals	4-11
5.3 Contract Data	4-11
ANNEX 4A TYPICAL DATA SHEETS	4-13
ANNEX 4B EXPANDER-COMPRESSOR VENDOR DRAWING AND DATA REQUIREMENTS	4-21
ANNEX 4C EXPANDER-COMPRESSOR NOMENCLATURE	4-29
ANNEX 4D INSPECTOR'S CHECK LIST	4-31
ANNEX 4E FORCES AND MOMENTS	4-35
ANNEX 4F APPLICATION CONSIDERATIONS FOR ACTIVE MAGNETIC BEARINGS (INFORMATIVE)	4-39
ANNEX 4G LUBRICATION AND SEALING SYSTEMS	4-45
Figures	
4.2-1 Automatic Thrust Balancing System	4-3
4.C-1 Typical Expander-compressor Showing Nomenclature of Key Parts	4-30
4.E-1 Combined Resultants of the Forces and Moments of Corrections	4-36
4.G-1 Typical Lubrication System for an Expander-compressor	4-46

SECTION 1—GENERAL

1.1 SCOPE

This chapter, in conjunction with Chapter 1 of this standard, covers the minimum requirements for expander-compressor used in process air or gas services. This chapter covers only expanders and compressors on a common shaft (expander-compressor).

This chapter does not apply to expanders with separate output shafts (e.g., generator drives).

Hot gas expanders over 300°C (570°F) are not covered in this standard.

1.2 DEFINITION OF TERMS

Definitions of terms used in this chapter may be found in Chapter 1 of this standard. A cross-section showing nomenclature of expander-compressors may be found in Annex 4C.

SECTION 2—BASIC DESIGN

2.1 GENERAL

Expander-compressors shall be in accordance with 2.1 of Chapter 1 of this standard and the additional requirements as follows.

2.1.1 Performance

2.1.1.1 The expander shall meet at least 98% of the predicted efficiency at the normal operating point. The compressor shall deliver at least 98% of the normal head at the normal capacity. The compressor power at the normal condition shall not be more than 106% of that available from the expander, nor shall it be less than 96% of that available from the expander.

Note: Compressor-loaded expanders achieve a power balance that determines the speed of the machine. The above tolerances are needed to set limits beyond which hardware changes may be required to achieve a reasonable normal speed.

2.1.1.2 The compressor head-capacity characteristic curve shall rise continuously from the rated point to surge. The compressor, without the use of a bypass, shall be suitable for continuous operation at any capacity on the predicted performance curve(s) at least 10% greater than the predicted surge capacity shown in the proposal.

Note: It is common for flow to be bypassed around the compressor during normal operation.

2.2 MATERIALS

Materials shall be in accordance with 2.2 of Chapter 1 of this standard. Refer to Annex 1D for a table of typical materials.

2.3 CASINGS

Casings shall be in accordance with 2.3 of Chapter 1 of this standard and the additional requirements as follows.

2.3.1 Pressure-containing Casings

- **2.3.1.1** The purchaser will specify the system relief valve settings. The maximum allowable working pressure of the casing(s) shall be at least equal to the specified relief valve set pressure(s).

2.3.1.1.1 If a relief valve is not specified, the maximum allowable working pressure of an expander casing shall be at least 1.1 times the maximum specified inlet pressure (gauge).

2.3.1.1.2 If a relief valve is not specified, the maximum allowable working pressure of the compressor casing of an expander-compressor shall be at least 1.25 times the maximum specified discharge pressure (gauge) but not less than the maximum discharge pressure as defined in Chapter 1 of this standard.

Note: System pressure protection shall be furnished by the purchaser.

2.3.1.2 “O” rings, gaskets or other sealing devices which are commonly used on radially split casings shall be confined in machined grooves and shall be made of materials suitable for all specified service conditions.

2.3.1.3 Provisions for lifting the casings and removing the center section shall be provided.

2.3.2 Pressure Casing Connections

2.3.2.1 General

2.3.2.1.1 All openings or nozzles for piping connections on pressure casings shall be DN 15 (NPS 1/2) or larger (see 2.3.2.1.3 of Chapter 1).

2.3.2.2 Main Process Connections

Main process connections shall be in accordance with 2.3.2.2 of Chapter 1.

2.3.2.3 Auxiliary Connections

Auxiliary connections shall be in accordance with 2.3.2.3 of Chapter 1 and as follows.

2.3.2.3.1 If socket-welded and flanged or machined and studded openings are impractical, threaded connections may be used as follows:

- a. On non-weldable materials, such as cast iron.
- b. Where essential for maintenance (disassembly and assembly).

These threaded openings shall be as specified in 2.3.2.3.5 of Chapter 1.

2.3.3 Casing Support Structures

Note 1: Expander-compressors have no coupling, therefore, there are no special requirements for casing support structures. Expander-compressors are generally mounted with the expander on centerline supports and the compressor only loosely bolted or unbolted and allowed to float with the piping to account for thermal expansions and contractions.

Note 2: Expander-compressor units do not require highly finished mounting surfaces.

2.3.4 External Forces and Moments

2.3.4.1 Expander-compressor packages shall be designed to withstand external forces and moments on each nozzle calculated in accordance with Equations 4.E-1a or 4.E-1b and 4.E-2 of Annex 4E.

Note: Expander-compressor shaft alignment is not affected by piping forces since they do not have a coupling.

2.3.4.2 The vendor shall furnish the allowable forces and moments for each nozzle in tabular form.

2.4 INLET GUIDE VANES, VARIABLE NOZZLES, AND HEAT SHIELDS

2.4.1 Each expander shall be equipped with variable inlet guide vanes, variable nozzles, and heat shields.

Note: Variable inlet guide vanes permit the efficient conversion of head into velocity throughout the design range of the unit.

2.4.2 Inlet guide vanes shall be sized capable of flowing at least 110% of the maximum specified mass flow at the minimum specified inlet pressure and maximum specified inlet temperature.

2.4.3 Actuating devices shall be capable of operation at all specified operating conditions, including maximum inlet pressure, maximum flow and minimum discharge pressure.

Note: Variable inlet guide vanes are used for flow and pressure control. Precise control of the nozzles is necessary for smooth process operation.

2.4.4 Inlet guide vanes and actuators shall be capable of closing with maximum inlet pressure at all flow conditions.

Note: Adjustable nozzles are often required to control expander discharge pressure under conditions of restricted flow on the discharge. It is necessary for nozzles to close rapidly with minimal leakage; however, inlet guide vanes are not tight shutoff devices.

2.4.5 Inlet guide vanes may be coated to minimize friction.

2.4.6 When inlet guide vanes are used for toxic, flammable or explosive process gas, the linkage passing through the casing or enclosure shall be sealed.

2.4.7 When required, an insulating heat shield shall be provided between the cold expander process fluids and the bearing cavity. Heat shields shall be constructed of materials with good insulation properties. See Annex 1D of this standard for typical heat shield materials.

2.5 ROTATING ELEMENTS

2.5.1 General

2.5.1.1 Rotating elements shall be in accordance with Chapter 1 and the following paragraphs:

2.5.1.2 Each impeller and shaft shall be clearly marked with a unique identification number. This number shall be in an accessible area that is not prone to maintenance damage.

2.5.2 Shaft Sleeves

2.5.2.1 Unless other shaft protection is approved by the purchaser, renewable components shall be furnished at labyrinth shaft seal locations. Sleeves, spacers or bushings shall be made of materials that are corrosion-resistant in the specified service.

2.5.3 Shafts

2.5.3.1 Shafts shall be of one piece or permanently joined multiple piece construction, and may be hollow.

Note 1: Many expanders have multi piece construction hollow shafts that are joined by methods such as friction welding per ANSI/AWS—C6.1.

Note 2: Because these parts are permanently joined, trapped process gas is not a problem.

2.5.3.2 All welds on the shaft shall be inspected by ultrasonic or radiographic examination. After finish machining, the weld shall be inspected by magnetic particle or liquid penetrant examination. Refer to 4.2.2.1 of Chapter 1 of this standard for material inspection methods and 4.2.2.1.1 of Chapter 1 of this standard for acceptance criteria.

2.5.3.3 For precipitation-hardened stainless steel shafts with maximum journal velocities (trip speed) above 95 m/s (315 ft/sec.), the vendor shall provide a coating or overlay on the journals to prevent wire wooling.

Note: Chrome plating, weld overlay, High Velocity Oxygen Fuel (HVOF), High Velocity Liquid Fuel (HVLf) and graphite impregnation are some of the methods which have been used successfully to prevent wire wooling.

2.5.4 Impellers

For impeller requirements, see 2.5.10 of Chapter 1.

2.5.5 Thrust Balancing

2.5.5.1 A balance cavity, line and porting shall be provided if required to limit axial loads on the thrust bearings.

2.5.5.2 When an external balance line is provided, it shall be flanged and sized to handle balance drum gas leakage at twice the initial design labyrinth clearance without exceeding the load rating of the thrust bearings. If the balance line involves a purchaser's connection to his piping, then the connection sizes shall be indicated on the data sheets.

2.5.5.3 An automatic thrust equalizing valve shall be provided. This valve shall react to changes in thrust load as measured by thrust pressure (magnetic bearing current, etc.) to actively maintain a low thrust load on the thrust bearings by injecting to or venting from balancing chambers inside the machine. See Figure 4.2-1 for typical automatic thrust equalizing valve schematic.

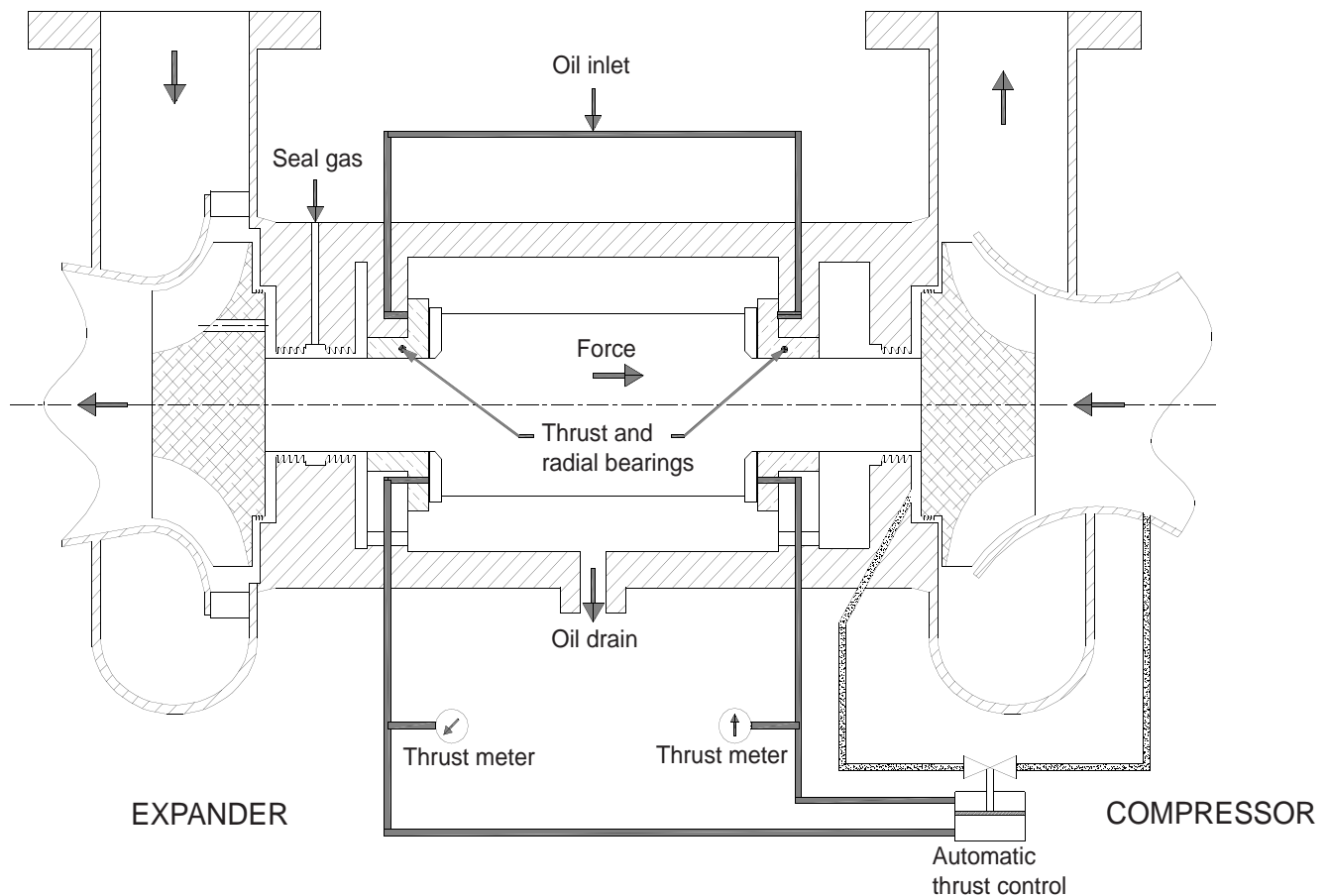

Figure 4.2-1—Automatic Thrust Balancing System

2.6 DYNAMICS

Dynamics shall be in accordance with 2.6 of Chapter 1.

2.6.1 Vibration Balancing

2.6.1.1 The balancing method described in 2.6.1.2 through 2.6.1.5 shall apply only to single-shaft expander-compressors which require rotor disassembly and reassembly to install. All other expander-compressors shall comply with 2.6.8 in Chapter 1.

Note: Expander-compressors in cryogenic service are typically single-shaft rotors which require disassembly and re-assembly of the rotor to install in the machine casing. A requirement of this type of machine is that either the compressor or expander component can be replaced individually without requiring the complete rotor to be rebalanced.

2.6.1.2 The expander wheel, compressor wheel, and the shaft shall be balanced using an index balancing procedure. All machining of components shall be completed before balancing. The wheels shall be supported by a concentric arbor during the balancing procedure. Two-plane balancing is preferred, but single-plane balancing may be used for components with a length to diameter (L/D) ratio of 0.2 or less. Each component shall be balanced so that the level of residual unbalance for each balance plane does not exceed the greatest value determined by the following expressions:

Note: For information on the index balance procedure refer to API Publ 684.

In SI units:

$$U = 6,350 (W/N), \text{ or}$$

$$U = 1.27 (W) \quad (4.2-1a)$$

In U.S. Customary units:

$$U = 4 (W/N), \text{ or}$$

$$U = 0.0008 (W) \quad (4.2-1b)$$

where

- U = residual unbalance, in g-mm (oz.-in.),
- W = weight of the component, in kg (lb.), apportioned to the balance planes so that the sum of the weight apportionments for both planes equals the total weight of the component,
- N = maximum continuous operating speed, in rpm.

2.6.1.3 Prior to starting the index balancing procedure for the compressor and expander wheels, the following steps

shall be performed to check the integrity of the fits between the wheels and arbor.

- a. Mount the wheel at an arbitrary 0° location on the arbor. Record the unbalance reading of the assembly.
- b. Dismount and remount the wheel on the arbor in the original 0° position. Record the unbalance.
- c. The reading from item b shall be within 20% of the reading from item a. If not, the arbor fit must be checked for poor contact, dirt, or other items affecting the fit integrity.

2.6.1.4 Index balance both wheels, using an arbor, to the tolerance specified in 2.6.1.2. After this step, the wheels should be in balance and no further corrections should be required.

2.6.1.5 The shaft index balance procedure shall be performed using both wheels mounted in the following manner:

- a. Mount the expander and compressor wheels on the shaft. Both wheels should be marked to an arbitrary 0° location on the shaft.
- b. Identify appropriate balance planes on the shaft. Perform index balancing of the shaft using the wheels to the tolerance specified in 2.6.1.2.

Note: Both wheels should be treated as one part and turned together during the index balancing procedure.

- **2.6.1.6** When specified, rotors shall be assembled and the balance verified. The residual unbalance for the randomly assembled components shall not exceed the greatest value determined by the following expressions:

In SI units:

$$U = 25,400 (W/N), \text{ or}$$

$$U = 12.7 (W) \quad (4.2-2a)$$

In U.S. Customary units:

$$U = 40 (W/N), \text{ or}$$

$$U = 0.008 (W) \quad (4.2-2b)$$

where

- U = residual unbalance, in g-mm (oz.-in.),
- W = weight of the rotor, in kg (lb.), apportioned to the balance planes so that the sum of the weight apportionment for both planes equals the total weight of the rotor,
- N = maximum continuous operating speed, in rpm.

Assembled rotors that fail to meet these criteria shall be balance corrected by repeating the component balance, not by trim balancing the assembly.

● 2.6.1.7 Residual Unbalance Procedure

When specified, a residual unbalance check shall be performed on assembled rotors. The residual unbalance check shall be performed after assembly balancing or assembly check-balancing is complete and before the assembled rotor is removed from the balancing machine.

Note: Refer to Annex 1B for a description of the procedure for residual unbalance verification.

2.7 BEARINGS AND BEARING HOUSINGS

2.7.1 General

2.7.1.1 Unless otherwise specified, hydrodynamic radial and thrust bearings shall be provided.

Note: The typical expander-compressor has both the radial and thrust bearing built into a single assembly.

● **2.7.1.2** When specified, magnetic bearings shall be supplied in accordance with Annex 4F.

2.7.1.3 Since the bearings are generally in contact with the process gas, bearing material selection criteria shall include compatibility with the process gas as well as the normal factors of strength, heat transfer rates, thermal growth properties, etc.

2.7.2 Hydrodynamic Radial Bearings

2.7.2.1 Sleeve or pad bearing types bearings shall be used. The bearings shall be precision machined. Materials used shall be steel, brass, bronze, aluminum, copper alloy or other suitable material.

Note: At bearing velocities less than 60 m/sec. (200 ft/sec.), an expander-compressor will typically use a babbited sleeve bearing. At velocities above 90 m/sec. (300 ft/sec.), babbited pad type bearings will typically be used. For speeds between these two values, the type of bearing may be either sleeve or pad type, depending on such factors as speed, oil flow requirements, rotor dynamics, etc.

2.7.2.2 The bearing design shall suppress hydrodynamic instabilities and provide sufficient damping over the entire range of allowable bearing clearances to limit rotor vibration to the maximum specified amplitudes (see 2.6.8.8 of Chapter 1 of this standard), while the equipment is operating loaded or unloaded, including operation at any critical frequency within the specified operating range.

2.7.2.3 Unless otherwise specified, hydrodynamic radial bearings shall be fitted with bearing metal temperature sensors installed in accordance with API Std 670.

2.7.3 Hydrodynamic Thrust Bearings

Hydrodynamic thrust bearings shall comply with the requirements of 2.7.3 of Chapter 1 and the following requirements:

2.7.3.1 Hydrodynamic thrust bearings shall be precision machined, continuous or segmented face design. Continuous face designs shall have grooving, such as spiral grooving, to allow oil distribution. Segmented face designs may be either fixed or tilting pad configuration. Materials used shall be steel, bronze, aluminum, copper alloy or other materials suitable for the application. Thrust bearings shall be designed for equal thrust capacity in both axial directions. Hydrodynamic thrust bearings shall be arranged for continuous pressurized lubrication to each side.

Note: A typical expander-compressor thrust bearing will be made of brass or bronze, have a tapered land or spiral groove face design, and be unbabbited.

2.7.3.2 Expander-compressors shall be equipped with automatic thrust equalizing valves to reduce the bearing loads for the specified conditions to a minimum, reducing expected loads no more than 50% of the ultimate capacity of the bearing (see Annex 4C).

Note: This device is normally a direct operated valve, using fluid pressures taken from the thrust bearing oil film for actuation.

2.7.4 Bearing Housings

2.7.4.1 Bearing housings shall be in accordance with 2.7.4 of Chapter 1 of this standard and the following requirements:

2.7.4.2 Rotor support system parts (bearings, bearing housings, bearing shells and bearing brackets) shall be separable from the mating casings.

Note: Expander bearing housings are normally pressurized.

2.8 EXPANDER-COMPRESSOR SHAFT SEALS

2.8.1 General

Shaft seals shall comply with the requirement of 2.8 of Chapter 1 of this standard and the following:

Note: Expander-compressors do not have shaft end seals, but the same types of seals are used for internal sealing between the process gas and the bearing housing.

2.8.1.1 Shaft seals shall be provided to restrict the leakage of process gas into the bearing housing over the range of specified operating conditions, including start-up and shut-down. Seals shall be suitable for specified variations in seal operating conditions that may prevail during start-up, shut-down, or settling out, and during any other special operation specified.

2.8.1.2 Shaft seals used in expanders may be either clearance seals (see 2.8.2 of Chapter 1 of this standard) or self-acting dry gas seals (see 2.8.4 of Chapter 1 of this standard).

2.9 GEARS

Gears are not applicable to expander-compressors.

2.10 LUBRICATION AND SEALING SYSTEMS

2.10.1 When required, a pressurized oil system shall be furnished to supply oil at suitable pressure(s) to the machine. Such systems shall be in accordance with of API Std 614, Chapters 1 and 2 as modified by Annex 4G.

2.11 NAMEPLATES AND ROTATION ARROWS

2.11.1 Nameplates and rotation arrows shall be in accordance with 2.11 of Chapter 1 of this standard.

Note: Rotation arrows are generally not provided for expander-compressors.

2.11.2 The following data shall be clearly stamped or engraved on the nameplate.

- Vendor's name.
- Serial number.
- Size, type and model number.
- Design power.
- Rated speed (rpm).
- Trip speed (rpm).
- Purchaser's item number or other reference.
- Maximum allowable working pressure of each casing.
- Maximum and minimum working temperature of each casing.
- Hydrostatic test pressure of each casing.
- Minimum and maximum allowable speed.
- Lateral critical speeds up to and including the next critical above maximum allowable speed (see 2.11.2.1 of Chapter 2 of this standard).

SECTION 3—ACCESSORIES

3.1 DRIVERS

Note: Expander-compressor units do not have separate drivers.

3.2 COUPLINGS AND GUARDS

Note: Expander-compressors do not have couplings and guards.

3.3 MOUNTING PLATES

3.3.1 Mounting plates shall be in accordance with the requirements of 3.3.1 and 3.3.2 of Chapter 1 of this standard and the following:

Note: Soleplates are not used with expanders.

3.3.1.1 Unless an externally connected piece of rotating equipment such as a generator is supplied, jackscrews and other leveling devices are not required.

3.3.2 General

The expander-compressor shall be furnished with a baseplate in accordance with 3.3 of Chapter 1 and the following:

Note: Expander-compressor units do not have couplings; therefore, sections of Chapter 1 that invoke requirements for alignment shims, machined surfaces, etc. are not applicable to expanders.

3.3.3 Baseplates

Baseplates shall be in accordance with 3.2.3 of Chapter 1.

3.3.4 Soleplates and Subsoleplates

Soleplates and subsoleplates are not applicable to expander-compressors (see 2.3.3).

3.4 CONTROLS AND INSTRUMENTATION

Controls and instrumentation shall be in accordance with 3.4 of Chapter 1 and the following:

3.4.1 General

3.4.1.1 Unless otherwise specified or modified below, instrumentation and installation shall conform to API Std 670.

3.4.2 Vibration, Position, and Bearing Temperature Detectors

3.4.2.1 Unless otherwise specified, vibration transducers shall be supplied, installed, and calibrated in accordance with API Std 670.

- **3.4.2.2** When specified, axial position probes shall be provided in accordance with API Std 670.

Note: Expander-compressors normally use pressure from active thrust compensation system rather than axial position probes for alarm/shutdown functions.

- **3.4.2.3** When specified, vibration monitors shall be supplied and calibrated in accordance with API Std 670.

3.4.2.4 Unless otherwise specified, hydrodynamic radial bearings shall be fitted with bearing-metal temperature sensors installed in accordance with API Std 670. The purchaser will specify the type of detector.

- **3.4.2.5** When specified, hydrodynamic thrust bearings shall be fitted with bearing-metal temperature sensors installed in accordance with API Std 670. The purchaser will specify the type of detector required.

3.4.2.6 When magnetic thrust and radial bearings have been specified, they shall be fitted with bearing temperature sensors installed in accordance with Annex 4F.

- **3.4.2.7** When specified, a bearing temperature monitor shall be supplied and calibrated in accordance with API Std 670.

3.4.3 Overspeed Shutdown System

3.4.3.1 General

3.4.3.1.1 Unless otherwise specified, an overspeed shutdown system based on a single circuit shall be provided.

Note: The design of an expander-compressor provides an inherent degree of overspeed protection. Overspeed primarily results from an interruption of flow to the compressor or operation, primarily during start-up, with a very low compressor suction pressure. The design of the piping system, including all valves and associated controls, should ensure that compressor flow interruption or very low suction pressure do not occur. Since the system is unlikely to produce an overspeed condition, single circuit overspeed detection and trip systems are the standard.

- **3.4.3.1.2** When specified, an overspeed shutdown system based on two-out-of-three voting logic shall be furnished.

3.4.3.1.3 The vendor shall design an overspeed shutdown system consisting of:

- a. Electronic overspeed circuit (speed sensor(s) and logic device).
- b. Expander inlet trip valve.
- c. Electric solenoid valves.

Note: Due to the wide variation in process services using expanders, it is not unusual for the expander inlet trip valve to be furnished by the purchaser.

3.4.3.2 Electronic Overspeed Detection Circuit

3.4.3.2.1 Unless otherwise specified, an electronic overspeed detection circuit, consisting of a speed sensor(s) and logic device, shall be furnished. Components shall be mounted per API Std 670. The design of the circuit shall include the following:

- a. Failure of either the sensor(s) or logic device shall initiate a shutdown.
- b. All settings incorporated in the overspeed circuit shall be protected through control access.
- c. It shall accept inputs from a frequency generator for verifying the trip speed setting.
- d. It shall provide an output for a speed indicator.

3.4.3.2.2 Unless otherwise specified, magnetic pickups shall be supplied for speed sensing.

3.4.3.2.3 A hole or grooved surface integral with the shaft shall be provided for speed sensing. The hole or grooved surface may be used by both the overspeed system and the tachometer sensors.

3.4.3.3 Expander Trip Valve

3.4.3.3.1 Unless otherwise specified, the vendor will provide an expander inlet trip valve that will close when the vendor's shutdown system senses overspeed. By design, the expander-compressor casing shall contain parts which might separate in the event of uncontrolled overspeed.

Note: Due to the wide variation in process services using expanders, it is not unusual for the expander inlet trip valve and solenoids to be furnished by the purchaser. The expander inlet trip valve is not the control mechanism for the expander. The trip valve is either full open or full closed (tripped). Capacity and speed control are provided by expander variable inlet nozzles, compressor minimum flow valve, or other means. The inclusion of a unit isolation valve upstream of the trip valve is typical of most installations, with provisions to depressurize the piping volume between the isolation and trip valves so that the trip valve does not have to be opened against full line pressure. The isolation valve is meant to close when the trip valve closes.

3.4.3.3.2 The design of expander inlet trip valves shall include, but not be limited to, the following:

- a. The ability to close rapidly within a time, typically 0.5 sec. or less, as agreed upon.
- b. Actuation from a fail-safe spring loaded actuator, a gas-operated actuator, or an air-operated actuator. If the design of the gas or air supply system could permit loss of gas or air pressure, then provide volume bottles with capacity for two full stroke closures of the trip valve. The torque capability of the actuator shall be sufficient to permit the valve to close with ice build up on it. Consideration shall be given to additional sealing devices such as flexible pressure-assisted seal rings to overcome the friction of ice build-up.
- c. An extended bonnet to maintain the stem packing at a non-cryogenic temperature.
- d. Special features to prevent ice, hydrates and other solids from stopping valve closure.

3.4.3.3.3 Electric Solenoid Valves

An electric solenoid-operated valve shall be provided to cause operation of the trip valve. Unless otherwise specified, the solenoid valve, shall be de-energized to trip.

Note 1: Solenoids can draw significantly high currents. Interposing relays should be used when the current requirements of the solenoid valve exceeds the current rating of the relay in the overspeed shutdown system.

Note 2: The purchaser should ensure that the electronic overspeed shutdown system is supplied from an uninterruptable power source.

3.4.3.4 Permanent Strainer

3.4.3.4.1 When specified, a permanent strainer for installation in a removable spool piece, with an effective free flow area at least twice the cross-sectional area of the expander inlet trip valves shall be furnished by the vendor.

Note: The spool piece is normally provided by the user. Differential pressure indication with a high pressure alarm switch should be provided for the strainer. The strainer should be located upstream of the trip valve.

- **3.4.3.4.2** When specified, the spool piece and differential pressure instrumentation for the permanent strainer shall be provided.
- **3.4.3.5** The vendor's design shall include a provision for local manual trip mechanism located near the expander inlet trip valve. Actuation of the manual trip mechanism shall close the trip valve and the variable inlet nozzles. When specified, the vendor shall furnish the local manual trip mechanism.
- 3.4.3.6** When the expander inlet trip valve is furnished by the purchaser, the vendor shall review the selection and shall provide recommendations concerning the sizing, location and closing time requirements.

SECTION 4—INSPECTION, TESTING, AND PREPARATION FOR SHIPMENT

Inspection, testing and preparation for shipment shall be in accordance with Section 4 of Chapter 1 of this standard and the following:

4.1 GENERAL

General requirements for inspection, testing and preparation for shipment shall be in accordance with 4.1 of Chapter 1. Also refer to Annex 4D for the Inspector's Checklist.

4.2 INSPECTION

Requirements for inspection shall be in accordance with Chapter 1 of this specification.

4.3 TESTING

4.3.1 General

4.3.1.1 In addition to the requirements of Chapter 1, 4.3, the expander-compressor(s) shall be tested in accordance with 4.3.3 and 4.3.4 of this chapter. Other optional tests that may be specified are described in 4.3.5.

4.3.1.2 Immediately upon completion of each witnessed mechanical or performance test, copies of the log data recorded during the test shall be given to the witnesses.

4.3.2 Wheel Shaker Test

4.3.2.1 For any new design which has not been previously built and tested, a shaker test will be performed to verify that the fundamental natural frequency of the blades and disk are in agreement with the range of predicted values calculated during the design phase.

3.5 PIPING AND APPURTENANCES

Piping and appurtenances furnished shall be in accordance with 3.5 of Chapter 1 of this standard and the following:

3.5.1 General

3.5.1.1 The vendor shall furnish all piping systems, including mounted appurtenances, located within the confines of the baseplate. The piping shall terminate with flanged connections at the edge of the baseplate. The purchaser will furnish only interconnection piping between equipment groupings and offbase facilities.

3.6 SPECIAL TOOLS

Special tools shall be furnished in accordance with 3.6 of Chapter 1 of this standard.

4.3.2.2 If this test does not validate the calculated values, the actual natural frequency shall be assessed against the operating speed range and power levels and the need for corrective action mutually agreed between the vendor and the purchaser.

4.3.2.3 If it is necessary to modify the wheel to adjust this natural frequency, the modified wheel shall be re-tested to confirm that the modification was successful.

4.3.3 Mechanical Running Test

4.3.3.1 The requirements of 4.3.3.1.1 through 4.3.3.1.11 shall be met before the mechanical running test is performed.

4.3.3.1.1 Unless otherwise agreed, the contract shaft seals and bearings shall be used in the machine for the mechanical running test.

Note 1: Test wheel seals may be required due to the temperature differences between operating conditions and test conditions. Under some circumstances, the compressor wheel will be replaced by a test wheel that closely matches the weight, center of gravity and moment of inertia of the actual wheel.

Note 2: A test wheel is typically used when the mechanical test would result in temperatures in the compressor which could cause damage to the actual wheel, or the expander cannot produce sufficient power on the test stand to achieve the desired speeds. The test wheel generates less heat and absorbs less power, thereby, eliminating this problem.

4.3.3.1.2 When oil lubricated bearings and/or seals are supplied, all oil pressures, viscosities, and temperatures shall be within the range of operating values recommended in the vendor's operating instructions for the specific unit being tested. Oil flow rates shall be measured.

4.3.3.1.3 Oil system components downstream of the filters shall meet the cleanliness requirements of API Std 614 before any test is started.

4.3.3.1.4 If magnetic bearings are used, the cooling air to the bearing cavity shall be established, levitation and turning of the magnetic bearings shall be checked per the manufacturer's instructions, and the magnetic bearing control package shall be exercised.

4.3.3.1.5 All joints and connections shall be checked for tightness, and any leaks shall be corrected.

4.3.3.1.6 All warning, protective, and control devices used during the test shall be checked, and adjusted as required.

4.3.3.1.7 All instrumentation used for the tests shall have valid calibration at the time of the test.

4.3.3.1.8 Facilities shall be installed to prevent the entrance of oil into the machine(s) during the mechanical running test. These facilities shall be in operation throughout the test.

4.3.3.1.9 All contract vibration probes, transducers and oscillator-demodulators shall be used during the test.

4.3.3.1.10 Shop test facilities shall include the capability of continuously monitoring, displaying, recording and printing vibration displacement and phase, vibration spectra, Bode plots, and shaft orbits.

4.3.3.1.11 The vibration characteristics determined using the instrumentation specified in 4.3.3.1.9 and 4.3.3.1.10 shall be the basis for acceptance or rejection of the machine (see 2.6.8.8 of Chapter 1).

4.3.3.2 The mechanical running test of the equipment shall be conducted as specified in 4.3.3.2.1 through 4.3.3.2.4.

4.3.3.2.1 The equipment shall be operated at speed increments of approximately 25% from zero to the maximum continuous speed until bearing temperatures, lube-oil temperatures (if applicable), and shaft vibrations have stabilized.

Note: Operating equipment at or near critical speeds should be avoided.

4.3.3.2.2 The equipment shall be run for 4 hours continuous operation at maximum continuous speed.

4.3.3.2.3 The speed shall be increased to trip speed and the equipment shall be run for a minimum of 15 min.

4.3.3.2.4 The unit shall be tripped and allowed to coast to a stop.

4.3.3.3 During the mechanical running test, the requirements of 4.3.3.3.1 through 4.3.3.3.6 shall be met.

4.3.3.3.1 During the mechanical running test, the mechanical operation of all equipment being tested and the operation of the test instrumentation shall be satisfactory. The measured

unfiltered vibration shall not exceed the limits of 2.6.8.8 of Chapter 1 and shall be recorded throughout the operating speed range. Any other test acceptance criteria shall be mutually agreed upon and stated in the test agenda.

4.3.3.3.2 While the equipment is operating at maximum continuous speed, or other speed and/or load that may have been specified in the test agenda, vibration data shall be acquired to determine amplitudes at frequencies other than synchronous. As a minimum, this data shall cover a frequency range from 0.25 – 8 times the maximum continuous speed. If the amplitude of any discrete, nonsynchronous vibration exceeds 20% of the allowable vibration as defined in 2.6.8.8 of Chapter 1 of this standard or 6.5 μm (0.25 mil), whichever is greater, the purchaser and the vendor shall mutually agree on requirements for any additional testing and on the equipment's acceptability.

4.3.3.3.3 The mechanical running test shall verify that lateral critical speeds conform to the requirements of 2.6.2 of Chapter 1 of this standard. Any non-critically damped critical speed below the trip speed shall be determined during the mechanical running test and stamped on the nameplate followed by the word "test."

4.3.3.3.4 Shop verification of the unbalanced response analysis shall be performed in accordance with 2.6.3 of Chapter 1.

- **4.3.3.3.5** When specified, all real-time vibration data as agreed by the purchaser and vendor shall be recorded and a copy provided to the purchaser.

4.3.3.3.6 When spare mechanical center sections are ordered to permit concurrent manufacture, each spare mechanical center section shall also be given a mechanical running test in accordance with the requirements of this standard.

4.3.3.4 Unless otherwise specified, the requirements of 4.3.3.4.1 through 4.3.3.4.4 shall be met after the mechanical running test is completed.

4.3.3.4.1 Hydrodynamic bearings shall be removed, inspected, and reassembled after the mechanical running test is completed.

- **4.3.3.4.2** When specified, shaft seals shall be removed for inspection following a successful running test.

Note: Removal and inspection of some seal types (such as cartridges) may require that the seal be returned to the seal manufacturer's facility.

4.3.3.4.3 If replacement or modification of bearings or seals or dismantling of the case to replace or modify other parts is required to correct mechanical or performance deficiencies, the initial test will not be acceptable, and the final shop tests shall be run after these replacements or corrections are made.

4.3.3.4.4 If minor scuffs and scratches occur on bearings or process gas seal surfaces, minor cosmetic repairs of these parts is not a cause for rerunning the test.

4.3.4 Assembled Machine Gas Leakage Test

4.3.4.1 After the mechanical running test is completed, each completely assembled machine casing intended for toxic or flammable gas service shall be tested for gas leakage.

Note: These tests are intended to verify the integrity of the casing joints.

4.3.4.2 The casing shall be pressurized to the lowest of the expander or compressor casing maximum allowable working pressure, held at this pressure for a minimum of 30 min. and subjected to a soap-bubble test or another approved method to check for gas leaks. The test shall be considered satisfactory when no casing or casing joint leaks are observed.

4.3.5 Optional Tests

When specified, the shop test described in 4.3.6 of Chapter 1 of this standard and/or the shop tests as described in 4.3.8.1 through 4.3.8.4 of Chapter 1 shall be performed. Test details shall be mutually agreed upon between the purchaser and the vendor prior to the test.

● 4.3.5.1 Performance Test

4.3.5.1.1 The expander shall be performance tested at the normal U/C ratio,

where

$$U = \text{expander wheel tip speed,}$$

$$C = \text{velocity equivalent to the enthalpy drop across the machine.}$$

Sufficient points shall be taken to either side of the peak to establish the expander efficiency parabolic curve. The measured efficiency shall be at least 98% of the predicted value.

Note 1: The expander U/C ratio is the single most important parameter effecting the machine performance. The typical expander is designed to peak at a U/C ratio (a dimensionless number) of 0.7.

Note 2: It may be necessary to perform corrections to the data such as when the expander U/C ratio and the Q/N ratio cannot be simultaneously met. (Q is the expander outlet volumetric flow rate and N is the normal speed of the machine.)

4.3.5.1.2 The compressor shall be performance tested at the normal Q/N ratio,

where

$$Q = \text{compressor inlet volume flow,}$$

$$N = \text{normal speed of the machine.}$$

A minimum of five points shall be taken to either side to establish a curve of the compressor head and efficiency vs. flow. The surge point shall be established and the observed surge point indicated on the performance test head curve. Other than this, the performance test shall be in accordance with ASME PTC10.

The compressor shall deliver at least 98% of the normal head at the normal capacity. The compressor power at the normal condition shall not be more than 106% of that available from the expander, nor shall it be less than 96% of that available from the expander.

Note: Refer to the applicable test code for general instructions. ASME PTC 10-1997 may not apply to some low-pressure ratio compressors. Refer to 1.2.2 of PTC 10-1997 for the selection of the appropriate test code to be used.

4.3.5.1.3 These tolerances shall be inclusive of all test tolerances.

Note: Both of the performance test codes referred to have provision for calculating inaccuracy based on instrumentation and procedures. These test inaccuracies are already included in the above tolerance and, therefore, are not to be further additive.

4.3.5.1.4 Unless otherwise specified, the performance test shall be conducted using only one contract mechanical center section.

● 4.3.5.2 Post-test Inspection of Machine Internals

The machine shall be dismantled, inspected, and reassembled after satisfactory completion of the mechanical running test. The purchaser will specify whether the gas test required by 4.3.4 shall be performed before or after the post-test inspection.

Note: The merits of post-test inspection of expander-compressor internals should be evaluated against the benefits of shipping a unit with proven mechanical assembly and casing joint integrity.

● 4.3.5.3 Spare-parts Test

Spare parts such as spare center sections, bearings and seal shall be tested, as specified.

Note: A mechanical test of the spare center section is mandated in 4.3.3.3.6.

4.4 PREPARATION FOR SHIPMENT

Preparation for shipment shall be in accordance with 4.4 of Chapter 1 and the following:

4.4.1 When a spare mechanical center section is purchased, it shall be prepared for unheated indoor storage for a period of at least 3 years.

SECTION 5—VENDOR'S DATA

Vendor data shall be provided in accordance with Section 5 of Chapter 1 of this standard and the following:

5.1 GENERAL

The information to be furnished by the vendor is specified in Annex 4B and in Section 5 of Chapter 1 of this standard. The vendor shall complete and forward the VDDR form in Annex 4B to the address or addresses noted in the inquiry or order. This form shall detail the schedule for transmission of drawings and data as agreed at the time of the order as well as the number and type of copies required by the purchaser.

5.2 PROPOSALS

5.2.1 Technical Data

Technical data shall be in accordance with 5.2.3 of Chapter 1 and the following:

5.2.1.1 Curves

5.2.1.1.1 Performance curves shall be submitted for each compressor and expander. These curves shall encompass the map of operations, with any limitations indicated thereon. All curves shall be marked "PREDICTED."

5.2.1.1.2 Predicted curves provided for expander-compressors shall include the following:

a. Expander power vs. flow.

b. Compressor power vs. flow.

c. Compressor head and pressure ratio vs. flow for at least 4 speed lines from 70% – 110% of normal speed.

d. Expander U/C vs. efficiency.

The compressor curves shall indicate the complete operating range.

5.3 CONTRACT DATA

Contract data shall be in accordance with 5.3 of Chapter 1 with the following additions:

5.3.1 General

5.3.2 Drawings and Technical Data

5.3.2.1 Curves

Curves shall be provided in accordance with 5.3.2.1 of Chapter 1 and the following:

5.3.2.2 If a performance test is specified, the vendor shall provide test data and curves when the test has been completed. Curves for the as-tested performance of the expander shall include expander U/C vs. efficiency (see 4.3.5.1.1). Compressor curves shall show head and efficiency vs. flow. The surge points shall be shown on the compressor performance curves.

.....

**ANNEX 4A
TYPICAL DATA SHEETS**

TURBOEXPANDER/COMPRESSOR DATA SHEET U.S. CUSTOMARY UNITS	JOB NO. _____ ITEM NO. _____ REVISION NO. _____ DATE _____ PAGE <u> 2 </u> OF <u> 6 </u> BY _____
---	---

1 OPERATING CONDITIONS (Continued)									
2 GAS ANALYSIS:		NORMAL		CASE A		CASE B		SEAL	REMARKS:
3 <input type="radio"/> MOL % <input type="radio"/> WT %		EXP	COMP	EXP	COMP	EXP	COMP	GAS	
4 _____ MW									
5 HELIUM 4.000									
6 HYDROGEN 2.016									
7 NITROGEN 28.016									
8 WATER VAPOR 18.016									
9 CARBON DIOXIDE 44.010									
10 HYDROGEN SULFIDE 34.076									
11 METHANE 16.042									
12 ETHYLENE 28.052									
13 ETHANE 30.068									
14 PROPYLENE 42.078									
15 PROPANE 44.094									
16 I-BUTANE 58.120									
17 n-BUTANE 58.120									
18 I-PENTANE 72.146									
19 n-PENTANE 72.146									
20 HEXANE PLUS									
21 _____									
22 _____									
23 _____									
24 _____									
25 TOTAL									
26 AVG. MOL. WT.									
27 SITE DATA					APPLICABLE SPECIFICATIONS:				
28 <input type="radio"/> ELEVATION _____ FT BAROMETER _____ PSIA					<input type="radio"/> VENDOR STANDARD				
29 <input type="radio"/> RANGE OF AMBIENT TEMPS:					<input type="radio"/> API 617, 7TH EDITION				
30 NORMAL _____ °F					<input type="radio"/> OTHER: _____				
31 MAXIMUM _____ °F					NOISE SPECIFICATIONS:				
32 MINIMUM _____ °F					<input type="radio"/> VENDOR STANDARD				
33 LOCATION:					<input type="radio"/> PURCHASER SPECIFICATION				
34 <input type="radio"/> INDOOR <input type="radio"/> OUTDOOR <input type="radio"/> GRADE					<input type="radio"/> SEE SPECIFICATION				
35 <input type="radio"/> HEATED <input type="radio"/> UNDER ROOF <input type="radio"/> MEZZANINE					ACOUSTIC COVERING: <input type="radio"/> YES <input type="radio"/> NO				
36 <input type="radio"/> UNHEATED <input type="radio"/> PARTIAL SIDES <input type="radio"/> _____					PAINTING:				
37 <input type="radio"/> AREA CLASSIFICATION NEC _____ IEC _____					<input type="radio"/> VENDOR STANDARD				
38 CLASS _____ GROUP _____ DIV. _____					<input type="radio"/> OTHER _____				
39 ZONE _____ GROUP _____ TEMP CLASS _____					SHIPPING PREPARATION:				
40 UNUSUAL CONDITIONS: <input type="radio"/> DUST <input type="radio"/> FUMES					<input type="radio"/> DOMESTIC PACKING				
41 <input type="radio"/> WINTERIZATION REQ'D. <input type="radio"/> TROPICALIZATION REQ'D.					<input type="radio"/> EXPORT PACKING (MIL-P 116J METHOD II)				
42 <input type="radio"/> OTHER _____					<input type="radio"/> SPECIAL: _____				
43 _____					DELIVERY:				
44 REMARKS: _____					<input type="radio"/> FCA FACTORY <input type="radio"/> FOB SITE (DOMESTIC ONLY)				
45 _____					<input type="radio"/> OTHER: _____				
46 _____					SPARE ROTATING ASSEMBLY:				
47 _____					<input type="radio"/> WOODEN SHIPPING CONTAINER				
48 _____					<input type="radio"/> METAL SHIPPING CONTAINER W/ PURGE PROVISION				
49 _____									

TURBOEXPANDER/COMPRESSOR DATA SHEET U.S. CUSTOMARY UNITS		JOB NO. _____ ITEM NO. _____ REVISION NO. _____ DATE _____ PAGE <u>3</u> OF <u>6</u> BY _____																																																																																																																																																																																																																																																												
1	CONSTRUCTION FEATURES																																																																																																																																																																																																																																																													
2	<input type="checkbox"/> SPEEDS:		<input type="checkbox"/> IMPELLERS:																																																																																																																																																																																																																																																											
3	MAX. CONT. _____ RPM TRIP _____ RPM	_____ EXP _____ COMP	<input type="checkbox"/> DIAMETER (IN.) _____																																																																																																																																																																																																																																																											
4	TIP SPEEDS: EXPANDER _____ FT/SEC. @ MCS	<input type="checkbox"/> TYPE (OPEN, ENCLOSED) _____	<input type="checkbox"/> TYPE FABRICATION _____																																																																																																																																																																																																																																																											
5	COMPRESSOR _____ FT/SEC. @ MCS	<input type="checkbox"/> EXPANDER WHEEL MATERIAL _____	<input type="checkbox"/> YIELD STRENGTH (KSI) MAX _____ MIN _____ (TYP)																																																																																																																																																																																																																																																											
6	<input type="checkbox"/> LATERAL CRITICAL SPEEDS (DAMPED)	<input type="checkbox"/> YIELD STRENGTH (KSI) MAX _____ MIN _____ (TYP)	<input type="checkbox"/> HARDNESS: _____ BNH/R _c (TYP)																																																																																																																																																																																																																																																											
7	FIRST CRITICAL _____ RPM BENDING MODE _____	<input type="checkbox"/> COMPRESSOR WHEEL MATERIAL _____	<input type="checkbox"/> YIELD STRENGTH (KSI) MAX _____ MIN _____ (TYP)																																																																																																																																																																																																																																																											
8	<input type="radio"/> UNDAMPED CRITICAL SPEED MAP	<input type="checkbox"/> HARDNESS: _____ BNH/R _c (TYP)	<input type="checkbox"/> SHAFT: _____																																																																																																																																																																																																																																																											
9	<input type="radio"/> COMPLETE ROTORDYNAMIC ANALYSIS	<input type="checkbox"/> CASINGS:	<input type="checkbox"/> MATERIAL _____																																																																																																																																																																																																																																																											
10		MODEL _____	SHAFT END: <input type="checkbox"/> TAPERED <input type="checkbox"/> CYLINDRICAL																																																																																																																																																																																																																																																											
11		<table border="1" style="width:100%; border-collapse: collapse;"> <thead> <tr> <th style="width: 5%;"></th> <th style="width: 25%;">EXP</th> <th style="width: 25%;">BRG HSG</th> <th style="width: 25%;">COMP</th> </tr> </thead> <tbody> <tr> <td><input type="checkbox"/> CASING SPLIT</td> <td>_____</td> <td>_____</td> <td>_____</td> </tr> <tr> <td><input type="checkbox"/> MATERIAL</td> <td>_____</td> <td>_____</td> <td>_____</td> </tr> <tr> <td><input type="checkbox"/> ASTM A-351 CF8</td> <td>_____</td> <td>_____</td> <td>_____</td> </tr> <tr> <td><input type="checkbox"/> ASTM A-352 LC3</td> <td>_____</td> <td>_____</td> <td>_____</td> </tr> <tr> <td><input type="checkbox"/> ASTM A-352 LCC</td> <td>_____</td> <td>_____</td> <td>_____</td> </tr> <tr> <td><input type="checkbox"/> ASTM A-216 WCB</td> <td>_____</td> <td>_____</td> <td>_____</td> </tr> <tr> <td><input type="checkbox"/> _____</td> <td>_____</td> <td>_____</td> <td>_____</td> </tr> <tr> <td><input type="radio"/> DESIGN PRES, PSIG</td> <td>_____</td> <td>_____</td> <td>_____</td> </tr> <tr> <td><input type="radio"/> MAX DESIGN TEMP, °F</td> <td>_____</td> <td>_____</td> <td>_____</td> </tr> <tr> <td><input type="radio"/> MIN. DESIGN TEMP, °F</td> <td>_____</td> <td>_____</td> <td>_____</td> </tr> <tr> <td><input type="radio"/> VISUAL INSPECTION</td> <td>_____</td> <td>_____</td> <td>_____</td> </tr> <tr> <td><input type="radio"/> CHARPY TESTING</td> <td>_____</td> <td>_____</td> <td>_____</td> </tr> <tr> <td><input type="radio"/> MAGNETIC PARTICLE</td> <td>_____</td> <td>_____</td> <td>_____</td> </tr> <tr> <td><input type="radio"/> LIQUID PENETRANT</td> <td>_____</td> <td>_____</td> <td>_____</td> </tr> <tr> <td><input type="radio"/> CRITICAL AREA X-RAY</td> <td>_____</td> <td>_____</td> <td>_____</td> </tr> <tr> <td><input type="radio"/> _____</td> <td>_____</td> <td>_____</td> <td>_____</td> </tr> <tr> <td><input type="radio"/> _____</td> <td>_____</td> <td>_____</td> <td>_____</td> </tr> <tr> <td><input type="checkbox"/> HYDROTEST PRESS <input type="checkbox"/> 1.5 × DESIGN <input type="checkbox"/> _____</td> <td>_____</td> <td>_____</td> <td>_____</td> </tr> <tr> <td><input type="radio"/> CASING LEAK TEST <input type="checkbox"/> 1.0 × DESIGN <input type="checkbox"/> _____</td> <td>_____</td> <td>_____</td> <td>_____</td> </tr> <tr> <td><input type="radio"/> 100% NITROGEN</td> <td>_____</td> <td>_____</td> <td>_____</td> </tr> <tr> <td><input type="radio"/> NITROGEN/HELIUM MIX (90/10)</td> <td>_____</td> <td>_____</td> <td>_____</td> </tr> <tr> <td><input type="radio"/> 100% HELIUM</td> <td>_____</td> <td>_____</td> <td>_____</td> </tr> <tr> <td>NOTE: LEAK TEST PERFORMED FOLLOWING</td> <td colspan="3"></td> </tr> <tr> <td>HYDROTEST USING SOAP BUBBLE METHOD</td> <td colspan="3"></td> </tr> <tr> <td style="text-align: center;">12</td> <td colspan="3"> <input type="checkbox"/> SHAFT SEALS: </td> </tr> <tr> <td style="text-align: center;">13</td> <td colspan="3"> <input type="checkbox"/> SINGLE PORT BUFFERED LABYRINTH </td> </tr> <tr> <td style="text-align: center;">14</td> <td colspan="3"> <input type="checkbox"/> DOUBLE PORT BUFFERED LABYRINTH </td> </tr> <tr> <td style="text-align: center;">15</td> <td colspan="3"> <input type="checkbox"/> TRIPLE PORT BUFFERED LABYRINTH </td> </tr> <tr> <td style="text-align: center;">16</td> <td colspan="3"> BLEED PRESSURE: _____ PSIG </td> </tr> <tr> <td style="text-align: center;">17</td> <td colspan="3"> <input type="checkbox"/> DRY GAS SEAL: _____ </td> </tr> <tr> <td style="text-align: center;">18</td> <td colspan="3"> <input type="radio"/> TYPE BUFFER GAS _____ </td> </tr> <tr> <td style="text-align: center;">19</td> <td colspan="3"> <input type="radio"/> BUFFER GAS SUPPLY PRESSURE _____ PSIG </td> </tr> <tr> <td style="text-align: center;">20</td> <td colspan="3"> <input type="checkbox"/> OTHER _____ </td> </tr> <tr> <td style="text-align: center;">21</td> <td colspan="3"> SEAL GAS REQUIREMENTS : </td> </tr> <tr> <td style="text-align: center;">22</td> <td colspan="3"> <input type="checkbox"/> TYPE: _____ </td> </tr> <tr> <td style="text-align: center;">23</td> <td colspan="3"> <input type="checkbox"/> MIN. SUPPLY PRESS. _____ PSIG </td> </tr> <tr> <td style="text-align: center;">24</td> <td colspan="3"> <input type="checkbox"/> MAX SUPPLY PRESS. _____ °F </td> </tr> <tr> <td style="text-align: center;">25</td> <td colspan="3"> <input type="checkbox"/> MIN SUPPLY TEMP. _____ °F </td> </tr> <tr> <td style="text-align: center;">26</td> <td colspan="3"> <input type="checkbox"/> MAX SUPPLY TEMP. _____ °F </td> </tr> <tr> <td style="text-align: center;">27</td> <td colspan="3"> <input type="checkbox"/> NORMAL FLOW _____ SCFM @ _____ PSI ΔP </td> </tr> <tr> <td style="text-align: center;">28</td> <td colspan="3"> <input type="checkbox"/> MAX FLOW _____ SCFM @ _____ PSI ΔP </td> </tr> <tr> <td style="text-align: center;">29</td> <td colspan="3"> <input type="radio"/> NOTE: PURCHASER TO SUPPLY SEAL GAS </td> </tr> <tr> <td style="text-align: center;">30</td> <td colspan="3"> COMPOSITION ON SHEET 2 </td> </tr> <tr> <td style="text-align: center;">31</td> <td colspan="3"></td> </tr> <tr> <td style="text-align: center;">32</td> <td colspan="3"></td> </tr> <tr> <td style="text-align: center;">33</td> <td colspan="3"></td> </tr> <tr> <td style="text-align: center;">34</td> <td colspan="3"></td> </tr> <tr> <td style="text-align: center;">35</td> <td colspan="3"></td> </tr> <tr> <td style="text-align: center;">36</td> <td colspan="3"></td> </tr> <tr> <td style="text-align: center;">37</td> <td colspan="3"></td> </tr> <tr> <td style="text-align: center;">38</td> <td colspan="3"></td> </tr> <tr> <td style="text-align: center;">39</td> <td colspan="3"></td> </tr> <tr> <td style="text-align: center;">40</td> <td colspan="3"></td> </tr> <tr> <td style="text-align: center;">41</td> <td colspan="3"></td> </tr> <tr> <td style="text-align: center;">42</td> <td colspan="3"></td> </tr> <tr> <td style="text-align: center;">43</td> <td colspan="3"></td> </tr> <tr> <td style="text-align: center;">44</td> <td colspan="3"></td> </tr> <tr> <td style="text-align: center;">45</td> <td colspan="3"></td> </tr> <tr> <td style="text-align: center;">46</td> <td colspan="3"></td> </tr> <tr> <td style="text-align: center;">47</td> <td colspan="3"></td> </tr> <tr> <td style="text-align: center;">48</td> <td colspan="3"></td> </tr> <tr> <td style="text-align: center;">49</td> <td colspan="3"></td> </tr> </tbody></table>		EXP	BRG HSG	COMP	<input type="checkbox"/> CASING SPLIT	_____	_____	_____	<input type="checkbox"/> MATERIAL	_____	_____	_____	<input type="checkbox"/> ASTM A-351 CF8	_____	_____	_____	<input type="checkbox"/> ASTM A-352 LC3	_____	_____	_____	<input type="checkbox"/> ASTM A-352 LCC	_____	_____	_____	<input type="checkbox"/> ASTM A-216 WCB	_____	_____	_____	<input type="checkbox"/> _____	_____	_____	_____	<input type="radio"/> DESIGN PRES, PSIG	_____	_____	_____	<input type="radio"/> MAX DESIGN TEMP, °F	_____	_____	_____	<input type="radio"/> MIN. DESIGN TEMP, °F	_____	_____	_____	<input type="radio"/> VISUAL INSPECTION	_____	_____	_____	<input type="radio"/> CHARPY TESTING	_____	_____	_____	<input type="radio"/> MAGNETIC PARTICLE	_____	_____	_____	<input type="radio"/> LIQUID PENETRANT	_____	_____	_____	<input type="radio"/> CRITICAL AREA X-RAY	_____	_____	_____	<input type="radio"/> _____	_____	_____	_____	<input type="radio"/> _____	_____	_____	_____	<input type="checkbox"/> HYDROTEST PRESS <input type="checkbox"/> 1.5 × DESIGN <input type="checkbox"/> _____	_____	_____	_____	<input type="radio"/> CASING LEAK TEST <input type="checkbox"/> 1.0 × DESIGN <input type="checkbox"/> _____	_____	_____	_____	<input type="radio"/> 100% NITROGEN	_____	_____	_____	<input type="radio"/> NITROGEN/HELIUM MIX (90/10)	_____	_____	_____	<input type="radio"/> 100% HELIUM	_____	_____	_____	NOTE: LEAK TEST PERFORMED FOLLOWING				HYDROTEST USING SOAP BUBBLE METHOD				12	<input type="checkbox"/> SHAFT SEALS:			13	<input type="checkbox"/> SINGLE PORT BUFFERED LABYRINTH			14	<input type="checkbox"/> DOUBLE PORT BUFFERED LABYRINTH			15	<input type="checkbox"/> TRIPLE PORT BUFFERED LABYRINTH			16	BLEED PRESSURE: _____ PSIG			17	<input type="checkbox"/> DRY GAS SEAL: _____			18	<input type="radio"/> TYPE BUFFER GAS _____			19	<input type="radio"/> BUFFER GAS SUPPLY PRESSURE _____ PSIG			20	<input type="checkbox"/> OTHER _____			21	SEAL GAS REQUIREMENTS :			22	<input type="checkbox"/> TYPE: _____			23	<input type="checkbox"/> MIN. SUPPLY PRESS. _____ PSIG			24	<input type="checkbox"/> MAX SUPPLY PRESS. _____ °F			25	<input type="checkbox"/> MIN SUPPLY TEMP. _____ °F			26	<input type="checkbox"/> MAX SUPPLY TEMP. _____ °F			27	<input type="checkbox"/> NORMAL FLOW _____ SCFM @ _____ PSI ΔP			28	<input type="checkbox"/> MAX FLOW _____ SCFM @ _____ PSI ΔP			29	<input type="radio"/> NOTE: PURCHASER TO SUPPLY SEAL GAS			30	COMPOSITION ON SHEET 2			31				32				33				34				35				36				37				38				39				40				41				42				43				44				45				46				47				48				49			
	EXP	BRG HSG	COMP																																																																																																																																																																																																																																																											
<input type="checkbox"/> CASING SPLIT	_____	_____	_____																																																																																																																																																																																																																																																											
<input type="checkbox"/> MATERIAL	_____	_____	_____																																																																																																																																																																																																																																																											
<input type="checkbox"/> ASTM A-351 CF8	_____	_____	_____																																																																																																																																																																																																																																																											
<input type="checkbox"/> ASTM A-352 LC3	_____	_____	_____																																																																																																																																																																																																																																																											
<input type="checkbox"/> ASTM A-352 LCC	_____	_____	_____																																																																																																																																																																																																																																																											
<input type="checkbox"/> ASTM A-216 WCB	_____	_____	_____																																																																																																																																																																																																																																																											
<input type="checkbox"/> _____	_____	_____	_____																																																																																																																																																																																																																																																											
<input type="radio"/> DESIGN PRES, PSIG	_____	_____	_____																																																																																																																																																																																																																																																											
<input type="radio"/> MAX DESIGN TEMP, °F	_____	_____	_____																																																																																																																																																																																																																																																											
<input type="radio"/> MIN. DESIGN TEMP, °F	_____	_____	_____																																																																																																																																																																																																																																																											
<input type="radio"/> VISUAL INSPECTION	_____	_____	_____																																																																																																																																																																																																																																																											
<input type="radio"/> CHARPY TESTING	_____	_____	_____																																																																																																																																																																																																																																																											
<input type="radio"/> MAGNETIC PARTICLE	_____	_____	_____																																																																																																																																																																																																																																																											
<input type="radio"/> LIQUID PENETRANT	_____	_____	_____																																																																																																																																																																																																																																																											
<input type="radio"/> CRITICAL AREA X-RAY	_____	_____	_____																																																																																																																																																																																																																																																											
<input type="radio"/> _____	_____	_____	_____																																																																																																																																																																																																																																																											
<input type="radio"/> _____	_____	_____	_____																																																																																																																																																																																																																																																											
<input type="checkbox"/> HYDROTEST PRESS <input type="checkbox"/> 1.5 × DESIGN <input type="checkbox"/> _____	_____	_____	_____																																																																																																																																																																																																																																																											
<input type="radio"/> CASING LEAK TEST <input type="checkbox"/> 1.0 × DESIGN <input type="checkbox"/> _____	_____	_____	_____																																																																																																																																																																																																																																																											
<input type="radio"/> 100% NITROGEN	_____	_____	_____																																																																																																																																																																																																																																																											
<input type="radio"/> NITROGEN/HELIUM MIX (90/10)	_____	_____	_____																																																																																																																																																																																																																																																											
<input type="radio"/> 100% HELIUM	_____	_____	_____																																																																																																																																																																																																																																																											
NOTE: LEAK TEST PERFORMED FOLLOWING																																																																																																																																																																																																																																																														
HYDROTEST USING SOAP BUBBLE METHOD																																																																																																																																																																																																																																																														
12	<input type="checkbox"/> SHAFT SEALS:																																																																																																																																																																																																																																																													
13	<input type="checkbox"/> SINGLE PORT BUFFERED LABYRINTH																																																																																																																																																																																																																																																													
14	<input type="checkbox"/> DOUBLE PORT BUFFERED LABYRINTH																																																																																																																																																																																																																																																													
15	<input type="checkbox"/> TRIPLE PORT BUFFERED LABYRINTH																																																																																																																																																																																																																																																													
16	BLEED PRESSURE: _____ PSIG																																																																																																																																																																																																																																																													
17	<input type="checkbox"/> DRY GAS SEAL: _____																																																																																																																																																																																																																																																													
18	<input type="radio"/> TYPE BUFFER GAS _____																																																																																																																																																																																																																																																													
19	<input type="radio"/> BUFFER GAS SUPPLY PRESSURE _____ PSIG																																																																																																																																																																																																																																																													
20	<input type="checkbox"/> OTHER _____																																																																																																																																																																																																																																																													
21	SEAL GAS REQUIREMENTS :																																																																																																																																																																																																																																																													
22	<input type="checkbox"/> TYPE: _____																																																																																																																																																																																																																																																													
23	<input type="checkbox"/> MIN. SUPPLY PRESS. _____ PSIG																																																																																																																																																																																																																																																													
24	<input type="checkbox"/> MAX SUPPLY PRESS. _____ °F																																																																																																																																																																																																																																																													
25	<input type="checkbox"/> MIN SUPPLY TEMP. _____ °F																																																																																																																																																																																																																																																													
26	<input type="checkbox"/> MAX SUPPLY TEMP. _____ °F																																																																																																																																																																																																																																																													
27	<input type="checkbox"/> NORMAL FLOW _____ SCFM @ _____ PSI ΔP																																																																																																																																																																																																																																																													
28	<input type="checkbox"/> MAX FLOW _____ SCFM @ _____ PSI ΔP																																																																																																																																																																																																																																																													
29	<input type="radio"/> NOTE: PURCHASER TO SUPPLY SEAL GAS																																																																																																																																																																																																																																																													
30	COMPOSITION ON SHEET 2																																																																																																																																																																																																																																																													
31																																																																																																																																																																																																																																																														
32																																																																																																																																																																																																																																																														
33																																																																																																																																																																																																																																																														
34																																																																																																																																																																																																																																																														
35																																																																																																																																																																																																																																																														
36																																																																																																																																																																																																																																																														
37																																																																																																																																																																																																																																																														
38																																																																																																																																																																																																																																																														
39																																																																																																																																																																																																																																																														
40																																																																																																																																																																																																																																																														
41																																																																																																																																																																																																																																																														
42																																																																																																																																																																																																																																																														
43																																																																																																																																																																																																																																																														
44																																																																																																																																																																																																																																																														
45																																																																																																																																																																																																																																																														
46																																																																																																																																																																																																																																																														
47																																																																																																																																																																																																																																																														
48																																																																																																																																																																																																																																																														
49																																																																																																																																																																																																																																																														

TURBOEXPANDER/COMPRESSOR DATA SHEET U.S. CUSTOMARY UNITS	JOB NO. _____ ITEM NO. _____ REVISION NO. _____ DATE _____ PAGE <u>4</u> OF <u>6</u> BY _____
1 CONSTRUCTION FEATURES (CONTINUED)	
2 BEARINGS:	
3 RADIAL: 4 <input type="checkbox"/> TYPE: 5 <input type="checkbox"/> SLEEVE BEARING 6 <input type="checkbox"/> TILTING PAD BEARING 7 <input type="checkbox"/> ACTIVE MAGNETIC BEARING 8 <input type="checkbox"/> OTHER _____ 9 <input type="checkbox"/> MATERIAL: 10 <input type="checkbox"/> ALUMINUM (BABBITTED) 11 <input type="checkbox"/> BRASS/BRONZE(BABBITTED) 12 <input type="checkbox"/> CARBON STEEL (BABBITTED) 13 <input type="checkbox"/> OTHER _____ 14 <input type="checkbox"/> SHAFT DIA. (IN.) _____ 15 <input type="checkbox"/> MANUFACTURER _____ 15 BEARING TEMPERATURE DEVICES: 16 <input type="radio"/> TYPE 17 <input type="radio"/> THERMOCOUPLES TYPE: _____ 18 <input type="radio"/> RESISTANCE TEMP DETECTORS 19 <input type="radio"/> RESISTANCE MAT'L <input type="radio"/> _____ OHMS 20 <input type="radio"/> LOCATION/QTY 21 <input type="checkbox"/> SINGLE DUAL ELEMENT (MAIN & SPARE) ____ PER BRG 22 <input type="radio"/> TEMPERATURE PROTECTION LOGIC DEVICE: 23 <input type="radio"/> TEMPERATURE MONITOR <input type="radio"/> DCS 24 <input type="radio"/> PLC <input type="radio"/> OTHER _____ 25 <input type="radio"/> LOGIC DEVICE SUPPLIED BY: <input type="radio"/> VENDOR <input type="radio"/> PURCH 26 <input type="radio"/> LOCATION OF TEMPERATURE PROTECTION LOGIC DEVICE: 27 <input type="radio"/> LOCAL CONTROL PANEL <input type="radio"/> REMOTE CONTROL PANEL 28 <input type="radio"/> MAIN CONTROL ROOM <input type="radio"/> OTHER _____ 29 <input type="radio"/> BEARING TEMPERATURE DISPLAY TYPE: 30 <input type="radio"/> TEMPERATURE MONITOR <input type="checkbox"/> MODEL _____ 31 <input type="radio"/> ALPHANUMERIC DISPLAY 32 <input type="radio"/> MMI/VDU 33 <input type="radio"/> PURCHASER 34 <input type="radio"/> OTHER _____ 35 <input type="radio"/> DISPLAY DEVICE PROVIDED BY: <input type="radio"/> VENDOR <input type="radio"/> PURCH 36 <input type="radio"/> LOCATION OF TEMPERATURE DISPLAY DEVICE: 37 <input type="radio"/> LOCAL CONTROL PANEL <input type="radio"/> REMOTE CONTROL PANEL 38 <input type="radio"/> MAIN CONTROL ROOM <input type="radio"/> OTHER _____	THRUST: <input type="checkbox"/> TYPE: <input type="checkbox"/> TAPERED LAND THRUST BEARING <input type="checkbox"/> TILTING PAD THRUST BEARING <input type="checkbox"/> ACTIVE MAGNETIC THRUST BEARING <input type="checkbox"/> OTHER _____ <input type="checkbox"/> MANUFACTURER _____ LUBRICATION: <input type="checkbox"/> FLOODED <input type="checkbox"/> DIRECTED <input type="checkbox"/> N/A THRUST COLLAR/DISK: <input type="checkbox"/> INTEGRAL <input type="checkbox"/> SEPARATE VIBRATION DETECTORS: TYPE: <input type="checkbox"/> EDDY CURRENT <input type="checkbox"/> INDUCTIVE <input type="checkbox"/> _____ <input type="radio"/> MFR _____ <input type="checkbox"/> MODEL _____ <input type="radio"/> LOCATION AND QUANTITY: <input type="radio"/> NO. PER JOURNAL BEARING TOTAL NO. _____ <input type="radio"/> IF REQ'D, OSCILLATOR-DEMODULATORS SUPPLIED BY: <input type="radio"/> VENDOR <input type="radio"/> MODEL _____ <input type="radio"/> PURCHASER <input type="radio"/> MODEL _____ <input type="radio"/> MACHINE VIBRATION PROTECTION LOGIC DEVICE: <input type="radio"/> VIBRATION MONITOR <input type="radio"/> DCS <input type="radio"/> PLC <input type="radio"/> OTHER _____ <input type="radio"/> LOGIC DEVICE PROVIDED BY: <input type="radio"/> VENDOR <input type="radio"/> PURCH <input type="radio"/> LOCATION OF VIBRATION PROTECTION LOGIC DEVICE: <input type="radio"/> LOCAL CONTROL PANEL <input type="radio"/> REMOTE CONTROL PANEL <input type="radio"/> MAIN CONTROL ROOM <input type="radio"/> _____ <input type="radio"/> VIBRATION AMPLITUDE DISPLAY <input type="radio"/> VIBRATION MONITOR <input type="checkbox"/> MODEL _____ <input type="radio"/> ALPHANUMERIC DISPLAY <input type="radio"/> MMI/VDU <input type="radio"/> OTHER _____ <input type="radio"/> DISPLAY DEVICE PROVIDED BY: <input type="radio"/> VENDOR <input type="radio"/> PURCH <input type="radio"/> LOCATION OF DISPLAY DEVICE: <input type="radio"/> LOCAL CONTROL PANEL <input type="radio"/> REMOTE CONTROL PANEL <input type="radio"/> MAIN CONTROL ROOM <input type="radio"/> _____ <input type="radio"/> KEY PHASOR <input type="radio"/> YES <input type="radio"/> NO MAGNETIC BEARING CONTROL CABINET, IF REQUIRED <input type="radio"/> UPS SUPPLIED BY: <input type="radio"/> VENDOR <input type="radio"/> PURCHASER <input type="radio"/> LOCATION OF CONTROL CABINET: <input type="radio"/> LOCAL PANEL <input type="radio"/> REMOTE PANEL <input type="radio"/> MAIN CONTROL ROOM <input type="radio"/> _____ <input type="radio"/> CABLE LENGTH FROM MACHINE SKID TO CONTROL CABINET: _____ FT <input type="radio"/> POWER AND SIGNAL CABLES: <input type="radio"/> SUPPLIED BY PURCHASER <input type="radio"/> SUPPLIED BY VENDOR <input type="radio"/> COMMUNICATION PROTOCOL <input type="radio"/> MODBUS <input type="radio"/> OTHER: _____ <input type="checkbox"/> POWER CONSUMPTION: kW _____
39 SPEED PROBES: 40 <input type="radio"/> TYPE: <input type="radio"/> ELECTROMAGNETIC <input type="radio"/> EDDY CURRENT 41 <input type="radio"/> QUANTITY _____ 42 43 <input type="radio"/> MACHINE PROTECTION LOGIC DEVICE: 44 <input type="radio"/> SWITCH <input type="radio"/> SPEED MONITOR <input type="radio"/> _____ 45 <input type="radio"/> LOCATION OF SPEED DISPLAY: 46 <input type="radio"/> LOCAL PANEL <input type="radio"/> REMOTE DISPLAY	

TURBOEXPANDER/COMPRESSOR DATA SHEET U.S. CUSTOMARY UNITS		JOB NO. _____ ITEM NO. _____ REVISION NO. _____ DATE _____ PAGE <u>5</u> OF <u>6</u> BY _____			
1	<input type="checkbox"/> OTHER CONNECTIONS		<input type="radio"/> ALLOWABLE PIPING FORCES AND MOMENTS: <input type="radio"/> 1.85 × NEMA SM23 <input type="radio"/> 3 × NEMA SM23 <input type="radio"/> OTHER: _____		
2	SERVICE:				
3	LUBE-OIL INLET	NO.		SIZE	TYPE
4	LUBE-OIL OUTLET				
5	SEAL-GAS INLET				
6	SEAL-GAS OUTLET				
7	CASING DRAINS, EXP/COMP				
8	INTERMEDIATE BLEED				
9	THRUST PRESSURES				
10	WHEEL PRESSURES, EX/COM				
11	BEARING HOUSING PRES				
12					
13					
14					
15					
16 ACCESSORIES					
17	<input type="radio"/> EXPANDER INLET TRIP VALVE:				
18	<input type="radio"/> TYPE:				
19	<input type="radio"/> BUTTERFLY VALVE <input type="radio"/> SIZE: _____ <input type="radio"/> RATING: _____ <input type="radio"/> ALLOWABLE PRESSURE DROP: _____ PSID				
20	<input type="radio"/> OTHER: _____				
21	<input type="radio"/> DESIGN PRESSURE: _____ PSIG <input type="radio"/> DESIGN TEMPERATURE (MIN/MAX) _____ / _____ °F				
22	<input type="radio"/> MATERIAL:				
23	<input type="radio"/> STAINLESS STEEL <input type="radio"/> LOW TEMP CARBON STEEL <input type="radio"/> CARBON STEEL <input type="radio"/> OTHER: _____				
24	<input type="radio"/> TRIP VALVE SUPPLIED BY: <input type="radio"/> VENDOR <input type="radio"/> PURCHASER				
25	<input type="radio"/> INLET SCREENS AND PIPE SPOOLS:				
26	<u>INLET SCREENS:</u>	EXP	COMP	<u>INLET SPOOLS FOR INLET SCREENS:</u>	
27	TYPE: (CONE, BASKET, OTHER)			SIZE	
28	SIZE (DIA. IN INCHES)			RATING	
29	MESH SIZE			FACING	
30	PRESSURE DROP (PSID)			DESIGN PRESSURE: PSIG	
31	MATERIAL:			DESIGN TEMPERATURE (MIN/MAX) °F	
32	STAINLESS STEEL	<input type="radio"/>	<input type="radio"/>	DESIGN TEMPERATURE (MIN/MAX) °F	
33	OTHER _____	<input type="radio"/>	<input type="radio"/>	MATERIAL:	
34				STAINLESS STEEL	
35	INLET SCREENS SUPPLIED BY:			LOW TEMP CARBON STEEL	
36	<input type="radio"/> VENDOR			CARBON STEEL	
37	<input type="radio"/> PURCHASER			OTHER: _____	
38				SPOOL CONSTRUCTION:	
39				SLIP-ON/SOCKETWELD	
40				SOCKETWELD	
41				WELDNECK/BUTTWELD	
42				PIPE SPECIFICATION: _____	
43					
44	<input type="radio"/> COMPRESSOR ANTI-SURGE SYSTEM				
45	CONTROLLER: <input type="radio"/> PID CONTROLLER <input type="radio"/> OTHER: _____				
46	<input type="radio"/> RECYCLE VALVE TYPE: _____ MTL: _____ NOISE LIMIT: <input type="radio"/> VENDOR STD <input type="radio"/> SPECIAL: _____				
47	<input type="radio"/> DESIGN PRESSURE: _____ PSIG <input type="radio"/> DESIGN TEMPERATURE (MIN/MAX) _____ / _____ °F				
48	<input type="radio"/> INLET FLOW DEVICE TYPE: _____ <input type="radio"/> BY: _____				
49	<input type="radio"/> COMP. INLET FLOW TRANSMITTER <input type="radio"/> COMP. DIFF. PRESSURE TRANSMITTER				

TURBOEXPANDER/COMPRESSOR DATA SHEET U.S. CUSTOMARY UNITS				JOB NO. _____ ITEM NO. _____ REVISION NO. _____ DATE _____ PAGE <u>6</u> OF <u>6</u> BY _____	
1	SHOP INSPECTION AND TESTS:				<input type="radio"/> UTILITY CONDITIONS: INSTRUMENT AIR FOR GUIDE VANE ACTUATOR: MAX PRESS _____ PSIG MIN PRESS _____ PSIG
2		REQ'D	OBSRV	WTNS	MISCELLANEOUS: <input type="checkbox"/> RECOMMENDED STRAIGHT RUN OF PIPE DIAMETERS AT EXPANDER DISCHARGE: _____ AT COMPRESSOR INLET: _____ <input type="radio"/> VENDOR TO REVIEW & COMMENT ON PURCHASER'S PIPING & FOUNDATION <input type="radio"/> VENDOR TO REVIEW & COMMENT ON PURCHASER'S CONTROL SYSTEMS _____ _____ _____
3	CLEANLINESS	<input type="radio"/>	<input type="radio"/>	<input type="radio"/>	
4	HYDROSTATIC	<input type="radio"/>	<input type="radio"/>	<input type="radio"/>	
5	LOW SPEED BALANCE (ISO 1940 G2.5)	<input type="radio"/>	<input type="radio"/>	<input type="radio"/>	
6	IMPELLER OVERSPEED (115% OF MCS)	<input type="radio"/>	<input type="radio"/>	<input type="radio"/>	
7	IMPELLER RESONANCE TEST	<input type="radio"/>	<input type="radio"/>	<input type="radio"/>	
8	MECHANICAL RUN	<input type="radio"/>	<input type="radio"/>	<input type="radio"/>	
9	<input type="radio"/> MAIN <input type="radio"/> SPARE				
10	<input type="radio"/> CONTRACT PROBES <input type="radio"/> SHOP PROBES				
11	VARY LUBE & SEAL OIL PRESSURES	<input type="radio"/>	<input type="radio"/>	<input type="radio"/>	
12	AND TEMPERATURES				
13	POLAR FORM VIB DATA	<input type="radio"/>	<input type="radio"/>	<input type="radio"/>	
14	TAPE RECORD VIB DATA	<input type="radio"/>	<input type="radio"/>	<input type="radio"/>	
15	TAPE DATA TO PURCHASER	<input type="radio"/>	<input type="radio"/>	<input type="radio"/>	
16	PERFORMANCE TEST (AIR)	<input type="radio"/>	<input type="radio"/>	<input type="radio"/>	
17	COMPLETE UNIT TEST	<input type="radio"/>	<input type="radio"/>	<input type="radio"/>	
18	HE/N ₂ CASING LEAK TEST	<input type="radio"/>	<input type="radio"/>	<input type="radio"/>	
19	SOUND LEVEL TEST	<input type="radio"/>	<input type="radio"/>	<input type="radio"/>	
20	FULL POWER TEST	<input type="radio"/>	<input type="radio"/>	<input type="radio"/>	
21	_____	<input type="radio"/>	<input type="radio"/>	<input type="radio"/>	
22	_____	<input type="radio"/>	<input type="radio"/>	<input type="radio"/>	
23	_____				
24	_____				
25	_____				
26	_____				
27	_____				
28	_____				
29					<input type="checkbox"/> SPACE REQUIREMENTS (FT & IN.): MACHINERY SKID: L _____ W _____ H _____ SUPPORT SYSTEM SKID: L _____ W _____ H _____
30					
31					
32					
33					
34					
35					
36					
37					
38	REMARKS:				
39	_____				
40	_____				
41	_____				
42	_____				
43	_____				
44	_____				
45	_____				
46	_____				
47	_____				
48	_____				

**ANNEX 4B
EXPANDER-COMPRESSOR VENDOR DRAWING
AND DATA REQUIREMENTS**

**API STANDARD 617
CHAPTER 4 ANNEX B
VENDOR DRAWING AND
DATA REQUIREMENTS**

PURCHASE ORDER NO. _____ DATE _____
 REQUISITION NO. _____ DATE _____
 INQUIRY NO. _____ DATE _____
 PAGE _____ OF _____ BY _____
 REVISION _____
 UNIT _____
 NO. REQUIRED _____

FOR _____
 SITE _____
 SERVICE _____

Proposal^a Bidder shall furnish _____ copies of data for all items indicated by an X.

Review^b Vendor shall furnish _____ copies and _____ transparencies of drawings and data indicated.

Final^c Vendor shall furnish _____ copies and _____ transparencies of drawings and data indicated.
 Vendor shall furnish _____ operating and maintenance manuals.

**DISTRIBUTION
RECORD**

Final—Received from vendor _____
 Final—Due from vendor^c _____
 Review—Returned to vendor _____
 Review—Received from vendor _____
 Review—Due from vendor^c _____

DESCRIPTION

No.	DESCRIPTION	Final ^c	Review ^b	Proposal ^a	Final—Received from vendor	Final—Due from vendor ^c	Review—Returned to vendor	Review—Received from vendor	Review—Due from vendor ^c
1.	Certified dimensional outline drawing and list of connections								
2.	Cross-sectional drawings and part numbers								
3.	Rotor assembly drawings and part numbers								
4.	Thrust-bearing assembly drawings and part numbers								
5.	Journal-bearing assembly drawings and bill of materials								
6.	Coupling assembly drawings and bill of materials								
7.	Lube-oil schematic and bill of materials								
8.	Lube-oil arrangement drawing and list of connections								
9.	Lube-oil component drawings and data								
10.	Seal system schematic and bill of material								
11.	Seal system arrangement drawing and list of connections								
12.	Seal system component drawings and data								
13.	Seal assembly drawing and part numbers								
14.	Electrical and instrumentation schematics and bill of materials								
15.	Electrical and instrumentation arrangement of drawing and list of connections								
16.	Buffer gas system schematic and bill of material								
17.	Buffer gas system arrangement drawing and list of connections								
18.	Buffer gas system component drawing and data								
19.	Data sheets (proposal/as-built)								
20.	Allowable external forces and moments for each nozzle in tabular form (with proposal)								
21.	Predicted noise sound level (proposal)								
22.	Metallurgy of major components (in proposal)								
23.	Lateral analysis report								
24.	Torsional analysis report								
25.	Vibration analysis report								

^aProposal drawings and data do not have to be certified or as-built.

^bPurchaser will indicate in this column the desired time frame for submission of materials, using the nomenclature given at the end of this form.

^cBidder shall complete this column to reflect his actual distribution schedule and include this form with his proposal.

^dThese items are normally provided only in instruction manuals.

^eIf furnished by the vendor.

^fIf specified.

**API STANDARD 617
CHAPTER 4 ANNEX B
VENDOR DRAWING AND
DATA REQUIREMENTS**

JOB NO. _____ ITEM NO. _____
PAGE _____ OF _____ BY _____
DATE _____ REVISION _____

Proposal^a Bidder shall furnish _____ copies of data for all items indicated by an X.

Review^b Vendor shall furnish _____ copies and _____ transparencies of drawings and data indicated.

Final^c Vendor shall furnish _____ copies and _____ transparencies of drawings and data indicated.
Vendor shall furnish _____ operating and maintenance manuals.

**DISTRIBUTION
RECORD**

Final—Received from vendor
Final—Due from vendor^c
Review—Returned to vendor
Review—Received from vendor
Review—Due from vendor^c

DESCRIPTION

No.	DESCRIPTION	Final ^c	Review ^b	Proposal ^a
26.	Performance curves for each compressor and expander			
27.	Impeller overspeed test report			
28.	Mechanical running test report			
29.	Coupling selection and rating			
30.	List of recommended spare parts			
31.	List of special tools			
32.	Preparation for storage at job site before installation			
33.	Weather protection and winterization required at job site			
34.	Tabulation of all utilities			
35.	List of similar machines			
36.	Operating restrictions to protect equipment during start-up operation and shutdown			
37.	List of components requiring purchaser's approval			
38.	Summary of materials and hardness of materials exposed to H ₂ S			
39.	Seal leakage rates			
40.	Interstage cooler system data			
41.	Drawings, details and description of instrumentation and controls			
42.	Minimum length of straight pipe required at machine inlet or side inlets			
43.	Maximum and minimum allowable seal pressure for each compressor			
44.	Statement of manufacturer's testing capabilities			
45.	Performance test data and curves			
46.	Back-to-back impeller machine vendor to provide thrust-bearing loads versus differential pressure curve			
47.	Balance piston leakage rates			
48.	When specified, vendor shall supply curves of balance piston line differential pressure versus thrust load			
49.	Production/delivery schedule			
50.	Testing procedures			
51.	Progress reports			
52.	Installation manual			
53.	Operating and maintenance manual			
54.	Technical data manual			

^aProposal drawings and data do not have to be certified or as-built.
^bPurchaser will indicate in this column the desired time frame for submission of materials, using the nomenclature given at the end of this form.
^cBidder shall complete this column to reflect his actual distribution schedule and shall include this form with his proposal.
^dThese items are normally provided only in instruction manuals.
^eIf furnished by the vendor.
^fIf specified.

**API STANDARD 617
CHAPTER 4 ANNEX B
VENDOR DRAWING AND
DATA REQUIREMENTS**

JOB NO. _____ ITEM NO. _____
PAGE _____ OF _____ BY _____
DATE _____ REVISION _____

Notes:

1. Where necessary to meet the scheduled shipping date, the vendor shall proceed with manufacture upon receipt of the order and without awaiting the purchaser's approval of drawings.
2. The vendor shall send all drawings and data to the following:

-
3. All drawings and data shall show project, purchase order, and item numbers as well as plant location and unit. One set of the drawings and instructions necessary for field installation, in addition to the copies specified above, shall be forwarded with shipment.
 4. See the descriptions of required items that follow.
 5. All of the information indicated on the distribution schedule shall be received before final payment is made.
 6. If typical drawings, schematics, bills of material are used for proposals, they shall be marked-up to show the expected weight and dimensions to reflect the actual equipment and scope proposed.

Nomenclature:

- S—number of weeks before shipment.
- F—number of weeks after firm order.
- D—number of weeks after receipt of approved drawings.

Vendor _____
 Date _____ Vendor Reference _____
 Signature _____
 (Signature acknowledges receipt of all instructions)

**API STANDARD 617
CHAPTER 4 ANNEX B
VENDOR DRAWING AND
DATA REQUIREMENTS**

JOB NO. _____ ITEM NO. _____
PAGE _____ OF _____ BY _____
DATE _____ REVISION _____

DESCRIPTION

1. Certified dimensional outline drawing and list of connections including the following:
 - a. The size, rating and location of all customer connections.
 - b. Approximate overall and handling weights.
 - c. Overall dimensions and maintenance and dismantling clearances.
 - d. Shaft centering height.
 - e. Dimensions of base plate (if furnished) for train or skid mounted package, complete with diameters, number and locations of bolt holes and thicknesses of sections through which the bolts must pass.
 - f. Grounding details.
 - g. Forces and moments allowed for suction and discharge nozzles.
 - h. Center of gravity and lifting points.
 - i. Shaft end separation and alignment data.
 - j. Direction of rotation.
 - k. Winterization, tropicalization and/or noise attenuation details, when required.
 - l. Sketches to show lifting of assembled machine and major components and auxiliaries.
2. Cross-sectional drawings and part numbers of major equipment.
3. Rotor assembly drawings and part numbers.
4. Thrust-bearing assembly drawings and part numbers.
5. Journal-bearing assembly drawings and bill of materials.
6. Coupling assembly drawing and bill of materials.
7. Lube-oil schematic and bill of material including the following:
 - a. Oil flows, temperatures and pressure at each point.
 - b. Control alarm shutdown settings for pressure and temperature.
 - c. Total heat loads.
 - d. Utility requirements including electrical, water, air and steam.
 - e. Pipe, valve and orifice sizes.
 - f. Instrumentation, safety devices, control schemes and wiring diagrams.
8. Lube-oil arrangement drawing and list of connections.
9. Lube-oil component drawings and data including the following:
 - a. Pumps and drivers.
 - b. Coolers, filter and reservoir.
 - c. Instrumentation.
10. Seal system schematic and bill of material including the following:
 - a. Flows oil or gas, temperatures and pressures at each point.
 - b. Control, alarm and shutdown settings for pressure and temperatures.
 - c. Total heat load for coolers, if required.
 - d. Utility requirements, including electrical, water, air and steam.
 - e. Pipe, valve and orifice sizes.
 - f. Instrumentation, safety devices, control schemes and wiring diagrams.
 - g. Filtration requirements.
 - h. Height of overhead tank above centerline of machine.
11. Seal system arrangement drawing and list of connections.

**API STANDARD 617
CHAPTER 4 ANNEX B
VENDOR DRAWING AND
DATA REQUIREMENTS**

JOB NO. _____ ITEM NO. _____
PAGE _____ OF _____ BY _____
DATE _____ REVISION _____

12. Seal system components drawing and data, including the following:
 - a. Pumps and drivers.
 - b. Coolers, filter and reservoirs.
 - c. Instrumentation.
13. Seal assembly drawing and part numbers.
14. Electrical and instrumentation arrangement drawing and list of connections.
 - a. Vibration warning and shutdown limits.
 - b. Bearing temperature warning and shutdown limits.
 - c. Lube-oil temperature warning and shutdown limits.
 - d. Lube-oil pressure warning and shutdown limits.
 - e. Lube-oil level warning and shutdown limits.
 - f. Machine discharge pressure and temperature warning and shutdown limits.
 - g. Seal, pressure, temperature, flow warning and shutdown limits.
15. Electrical and instrumentation arrangement drawing and list of connections.
16. Buffer gas system schematic and bill of material.
17. Buffer gas system schematic and bill of material.
18. Buffer gas system component drawings and data, including the following:
 - a. Control devices.
 - b. Pressure and filtration requirements.
19. Data sheets provided with proposal as-built.
20. The vendor shall furnish the allowable forces and moments for each nozzle in tabular form with the proposal.
21. Predicted noise level, sound pressure, and sound power level.
22. Metallurgy of major components identified with ASTM, AISI, ASME, or SAE numbers stated in proposal.
23. Lateral analysis report when specified shall also include a stability analysis.
24. Torsional analysis report.
25. Vibration analysis conducted on machines that require disassembly after balancing to allow machine assembly. The vendor shall also provide historic unbalance data for the machine size and type.
26. Performance data and curves shall be submitted to the purchaser with proposal.
27. Dimensions taken from each impeller before and after overspeed testing shall be submitted for review.
28. Mechanical running test report to include the following:
 - a. Unfiltered vibration.
 - b. Plots showing synchronous vibration and phase angle, filtered and unfiltered.
 - c. When specified data shall be furnished in polar form.
 - d. When specified tape recordings shall be made of all real time vibration data.
 - e. Electrical and mechanical runout at each probe.

Immediately upon completion of each witnessed mechanical or performance test, copies of the log and data recorded during the test shall be given to the witnesses.
29. Coupling selection and rating.
30. List of spare parts recommended for start-up and normal maintenance purposes.
31. List of the special tools furnished for maintenance.
32. The vendor shall provide the purchaser with instructions necessary to preserve the integrity of the storage preparation after the equipment arrives at the job site and prior to start-up.
33. A description of any special weather protection required for start-up, operation and period of idleness under the site conditions specified on the data sheets.

**API STANDARD 617
CHAPTER 4 ANNEX B
VENDOR DRAWING AND
DATA REQUIREMENTS**

JOB NO. _____ ITEM NO. _____
PAGE _____ OF _____ BY _____
DATE _____ REVISION _____

34. A complete list of utility requirements: quantity, filtration and supply pressure of the following:
 - a. Steam.
 - b. Water.
 - c. Electricity.
 - d. Air.
 - e. Gas.
 - f. Lube oil and seal oil (quantity and supply pressure).
 - g. Heat loads.
 - h. Power ratings and operating power requirements for auxiliary drivers.
35. A list of machines similar to the proposed machines that have been installed and operating under conditions analogous to those specified in the inquiry.
36. Any start-up, shutdown or operating restrictions required to protect the integrity of the equipment, including any unacceptable speeds due to natural frequencies.
37. A list of any components that can be construed as being of alternative design, requiring purchaser's acceptance.
38. A summary of the materials of construction for the compressor, including hardness for materials exposed to H₂S.
39. The maximum seal gas rates (injection or eduction) and rated or expected inner seal-oil leakage rates, if applicable. When self-acting dry gas seals are supplied, expected seal gas consumption, minimum seal gas supply flow and primary vent flow should be given at maximum sealing pressure and at conditions over the operating envelope of the machine.
40. When interstage coolers are furnished, the vendor shall provide the following:
 - a. Drawing showing cooling system details.
 - b. Data for purchasers heat and material balances.
 - c. Details of provisions for separating and withdrawing condensate.
 - d. Vendor's recommendations regarding provision for support and piping expansion.
41. Drawings, details and descriptions of the operations of instrumentation and controls as well as the makes, materials and type of auxiliary equipment. The vendor shall also include a complete description of the alarm and shutdown facilities to be provided.
42. The minimum length of straight pipe required for proper flow characteristics at the inlet and at any side inlet connection.
43. Maximum and minimum allowable seal pressure for each compressor.
44. A statement of the manufacturers capability regarding testing (including performance testing) of the compressor and any other specified items on the train. Details of each optional test specified shall be included.
45. Predicted performance curves shall be provided for compressor and expander including the following:
 - a. Expander power versus flow.
 - b. Compressor power versus flow.
 - c. Compressor head and ratio, four speed lines from 70% – 110% of normal speed lines.
 - d. Expander v/c versus efficiency.

If a performance test is specified as tested, then curves and data shall be provided.
46. For compressors that have a back-to-back impeller arrangement, the vendor shall furnish a curve showing the expected loading on the active or inactive side of the thrust bearing versus any combination of differential pressures across the low pressure and high pressure sections of the casing.
47. The vendor shall supply balance piston leakage based on design clearances and twice design clearances for the rated conditions.

**API STANDARD 617
CHAPTER 4 ANNEX B
VENDOR DRAWING AND
DATA REQUIREMENTS**

JOB NO. _____ ITEM NO. _____
PAGE _____ OF _____ BY _____
DATE _____ REVISION _____

48. When specified, the vendor shall supply curves of balance piston line differential pressure versus thrust load.
49. The vendor shall provide production and delivery schedules.
50. The vendor shall submit detailed procedures including acceptance criteria for the mechanical running test and all optional tests, at least 6 weeks prior to the first running test.
51. The vendor shall submit progress reports.
52. All information required for the proper installation of the equipment shall be compiled in a manual that must be issued no later than the time of final certified drawings.
53. A manual containing all required operating and maintenance instructions shall be supplied not later than 2 weeks after all specified test shall have been successfully completed.
54. The vendor shall provide a “technical data manual within 30 days of completion” of shop testing including the following:
 - a. Necessary certification of materials.
 - b. Purchase specification for all items on the bill of materials.
 - c. Test data to verify requirements of specifications have been met.
 - d. Heat treat records.
 - e. Results of quality test and inspections.
 - f. Mechanical running test data log.
 - g. Final assembly maintenance and running clearances.The vendor is also required to keep this data available for examination by the purchaser, upon request, for at least 5 years.

ANNEX 4C
EXPANDER-COMPRESSOR NOMENCLATURE

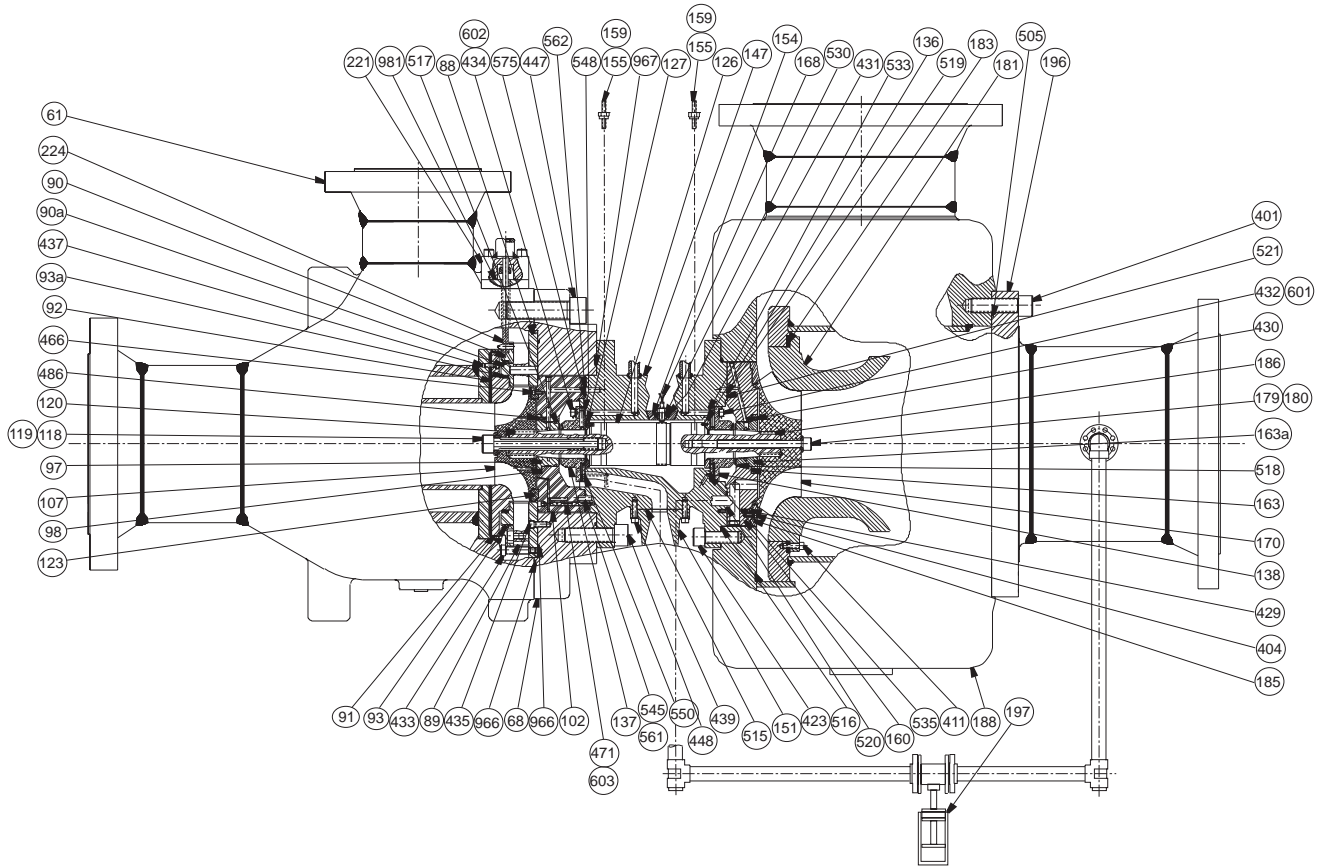

Key

Item No.	Description	Item No.	Description	Item No.	Description
61	Expander case	120	Shaft key (expander)	170	Compressor wheel
68	Labyrinth seal housing	123	Expander wheel back seal	179,180	Retaining screw and retaining washer
88	Nozzle cover	126	Shaft	181	Compressor follower
89	Nozzle segment and cam roller	127	Bearing thrust washer (expander)	183	Shim-compressor follower
90	Nozzle adjusting ring	136	Bearing thrust washer (compressor)	185	Compressor wheel back seal
90a	Nozzle clamping ring	137	Bearing-drive	186	Shaft key (compressor)
91	Nozzle fixed ring	138	Bearing-load	188	Compressor case
92	Shim-nozzle fixed ring	147	Bearing housing	196	Compressor inlet spacer
93	Piston ring	151	Bearing housing drain	197	Auto thrust balance assembly
93a	Seal ring	154	Tachometer pick-up insert	221	Actuator mount assembly
97	Heat barrier wall insert	155,159	Vibration pick-up and lock nut	224	Nozzle actuator rod
98	Shim-heat barrier wall insert	160	Compressor seal	401 - 486	Screw
102	Heat barrier wall	163	Compressor seal insert	505 - 575	O-ring
107	Expander wheel	163a	Shim-compressor seal insert	601 - 603	Washer
118,119	Retaining screw and retaining washer	168	Tachometer pick-up	966 - 981	Raco seal

Figure 4.C-1—Typical Expander-compressor Showing Nomenclature of Key Parts

**ANNEX 4D
INSPECTOR'S CHECK LIST**

Item	Standard 617		Reviewed	Observed	Witnessed	Inspected By	Status
	Par	Ch					
GENERAL							
Contract Review—Testing and Inspections Listed in Proposal	2.2.1.4	1					
General Test Requirements	4.1.1 4.1.3 4.1.4 4.1.4.1 4.1.6 4.1.7 4.2.1 4.2.1.2	1 1 1 1 1 1 1 1					
Cleanliness	4.2.1.3 4.2.1.4	1 1					
Hardness	4.2.1.5	1					
Case Support Mounting Surfaces	2.3.3	4					
Nameplate	2.11.2	4					
Rotation Arrows	2.11.1	4					
MATERIAL INSPECTIONS							
Material Inspections	4.2.2.1	1					
Castings	2.2.2.1	1					
Low Temperature Impact	2.2.1.15.5	1					
Forgings	2.2.3.2	1					
Weldings	2.2.4.1	1					
Pressure-containing Casings	2.3.1	1					
Material Inspection of Pressure-containing Parts	2.3.1.12	1					
ROTATING ELEMENT							
Impellers	2.5.10.4 2.5.10.5 2.5.10.6 4.3.3.1	1 1 1 1					
Overspeed	2.5.10.7 4.3.3.1	1 1					
Balance	2.6.8 2.6.8.8 Annex B	1 1					
Run-out	2.6.8.9 2.6.8.10	1 1					
ACCESSORIES							
Shaft End Seals	4.3.5 Annex D	1					
Lubrication and Sealing Systems	2.10.3 API Std 614	1					
Drivers	3.1	1					
Steam Turbine	3.1.4 API Std 612	1					
Motor	3.1.5 API Std 541	1					
Gas Turbine	3.1.7 API Std 616	1					
Separate Gear Units	3.1.8 API Std 613	1					
Coupling and Guard	3.2 API Std 671	1					

Item	Standard 617		Reviewed	Observed	Witnessed	Inspected By	Status
	Par	Ch					
Instrumentation	3.4.3 3.4.4 API Std 614 API Std 670	1 1					
Alarms and Shutdowns	3.4.5 API Std 614	1					
Electrical Systems	3.4.6 API Std 614 2.1.14	1 1					
Piping	3.5.1 API Std 614	1					
Special Tools	3.6.1 3.6.2	1 1					
TESTING							
Test Data Log	4.3.1.2	4					
Wheel Skaker Test to Verify Natural Frequency	4.3.2	4					
HYDROSTATIC TEST							
Hydrostatic Test	4.3.2.1 4.3.2.2 4.3.2.3	1 1 1					
OVERSPEED TEST							
Impeller Overspeed Test	4.3.3.1	1					
MECHANICAL RUNNING TEST							
Unbalance Response Verification	2.6.3.1	1					
Vibration Record	2.6.3.1.1 4.3.6.1.1 4.3.6.1.2 4.3.6.1.3	1 1 1 1					
Contract Shaft Seals Used in Test	4.3.6.1.4	1					
Oil Flow Rates P. & T.	4.3.3.1.2	4					
Oil System Clean	4.3.3.1.3	4					
Warning Protective Control Devices Checked	4.3.3.1.6	4					
Magnetic Bearing Check	4.3.3.1.4	4					
Connections Check for Leaks	4.3.3.1.5	4					
Vibration Levels	4.3.3.1.11	4					
Test Speeds Performed	4.3.3.2.1	4					
Test Run at Trip Speed	4.3.3.2.3	4					
4-hour Test Run	4.3.3.2.2	4					
Seal Flow Data	4.3.3.1.2	4					
Contract Shaft Seals Used in Test	4.3.3.1.1	4					
Test Instrumentation Check	4.3.3.1.7	4					
Lube and Seal Oil Flows Varied	4.3.6.1.5	1					
Vibration Levels	4.3.3.3.1 4.3.3.3.2	4 4					
Lateral Critical Speed Verified	4.3.3.3.3	4					
Unbalance Response Analysis Verified	4.3.3.3.4	4					
Spare Center Section Test	4.3.3.3.6	4					
Bearing Inspected After Test	4.3.3.4.1	4					
Seals Inspected After Test	4.3.3.4.2	4					
Assembled Compressor Gas Leak	4.3.4.1 4.3.4.2	4 4					

Item	Standard 617		Reviewed	Observed	Witnessed	Inspected By	Status
	Par	Ch					
OPTIONAL TESTING	4.3.5	4					
Performance Test	4.3.5.1	4					
	4.3.5.1.1	4					
	4.3.5.1.2	4					
	4.3.5.1.3	4					
	4.3.5.1.4	4					
Post-test Inspection	4.3.5.2	4					
Helium Test	4.3.8.2	1					
Sound-level Test	4.3.8.3	1					
Auxiliary Equipment Test	4.3.8.4	1					
Post-test Inspection of Compressor Internal	4.3.8.5	1					
Full-pressure/Full-load/Full-speed Test	4.3.8.6	1					
Post-test Inspection of Hydraulic Coupling Fit	4.3.8.7	1					
Spare Parts Test	4.3.8.8	1					
	4.3.5.3	4					
PREPARATION FOR SHIPMENT							
Equipment Prepared	4.4.1	1					
	4.4.2	1					
Paint	4.4.3.1	1					
Exterior Machined Surfaces Coated	4.4.3.2	1					
Bearing Housings, Oil Systems, Auxiliary Equipment and Piping Preserved	4.4.3.4	1					
Openings Covered and Protected	4.4.3.5	1					
	4.4.3.6	1					
	4.4.3.7	1					
Lifting Points Identified	4.4.3.8	1					
Equipment Identified, Tagged, Packing List	4.4.3.9	1					
Spare Rotor Prepared for Storage	4.4.3.10	1					
Exposed Shafts, etc. Prepared for Shipment	4.4.3.12	1					
Auxiliary Piping Connections Tagged or Stamped	4.4.4	1					
	4.4.5	1					
Installation, Instructions Shipped with Equipment	4.4.6	1					

ANNEX 4E FORCES AND MOMENTS

E.1 General

E.1.1 The April 1988, November 1979, and October 1973 issues of this standard referred nozzle forces and moments calculations to appropriate NEMA documents, with the stipulation that the constants in the equations be multiplied by 1.85. Experience has shown that there has not been a uniform interpretation of “1.85 times NEMA.” Therefore, the equations have been adapted to expander-compressors by identifying all the constants and clarifying that the equivalent of the exhaust nozzle in the NEMA calculation is the largest expander or compressor nozzle. This is usually, but not necessarily, the outlet nozzle.

E.1.2 For expanders designed for driving separate gearboxes or generators, which require high tolerance of alignment between the expanders and the gearboxes/generators, the vendor shall identify the maximum allowable forces and moments.

Note: 0.2 times NEMA is often required for this type of the arrangement.

E.2 Equations

The design of each expander-compressor body must allow for limited piping loads on the various casing nozzles. For maximum system reliability, nozzle loads imposed by piping should be as low as possible regardless of the expander-compressor load-carrying capability. For single stage expander-compressors, the forces and moments acting on expander or compressor due to the inlet and discharge connections should be limited by the following:

a. The total resultant force and total resultant moment imposed on the compressor at any connection should not exceed the values shown in Equations 4.E-1a or 4.E-1b.

In SI units:

$$F_r + 1.09 M_r \leq 54.1 D_e \quad (4.E-1a)$$

In U.S. Customary units:

$$3F_r + M_r \leq 927 D_e \quad (4.E-1b)$$

where

F_r = resultant force, in Newtons (lb.) (see Figure 4.E-1),

M_r = resultant moment, in Newton-meters (ft-lb.) from Figure 4.E-1.

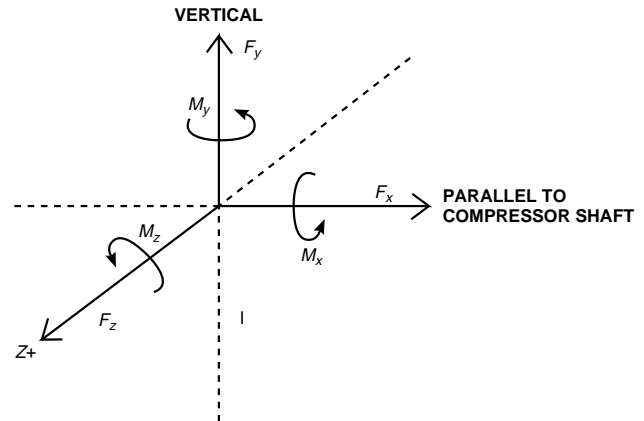

Figure 4.E-1—Combined Resultants of the Forces and Moments of Corrections

For sizes up to 200 mm (8 in.) in diameter:

$$(M_t = \sqrt{M_x + M_y + M_z}) \quad (4.E-2)$$

D_e = Nominal pipe diameter of the connection, in mm (in.).

For sizes greater than 200 mm (8 in.), use a value of:

In SI units:

$$D_e = \frac{400 + D_{nom}}{3} \text{ (mm)} \quad (4.E-3a)$$

In U.S. Customary units:

$$D_e = \frac{16 + D_{nom}}{3} \text{ (in.)} \quad (4.E-3b)$$

where

D_c = equivalent pipe diameter of the connection, in mm (in.),

D_{nom} = nominal pipe diameter, in mm (in.).

b. The combined resultants of the forces and moments of the inlet, sidestream, and discharge connections resolved at the centerlines of the largest connection should not exceed the following:

1. The resultants shall not exceed:

In SI units:

$$F_c + 1.64 M_c \leq 40.4 D_c \quad (4.E-4a)$$

In U.S. Customary units:

$$2F_c + M_c \leq 462D_c \quad (4.E-4b)$$

where

F_c = combined resultant of inlet, sidestream, and discharge forces, in Newtons (lb.),

M_c = combined resultant of inlet, sidestream, and discharge moments, and moments resulting from forces, in Newton-meters (ft-lb.),

D_c = diameter (in mm [in.]) of one circular opening equal to the total areas of the inlet, sidestream, and discharge openings. If the equivalent nozzle diameter is greater than 230 mm (9 in.), use a value of D_c equal to:

In SI units:

$$= \frac{(400 + \text{Equivalent Diameter})}{3} (\text{mm})$$

In U.S. Customary units:

$$= \frac{(18 + \text{Equivalent Diameter})}{3} (\text{in.})$$

2. The individual components (Figure 4.E-1) of these resultants should not exceed:

In SI units:

$$F_x = 16.1D_c \quad M_x = 24.6D_c$$

$$F_y = 40.5D_c \quad M_y = 12.3D_c$$

$$F_z = 32.4D_c \quad M_z = 12.3D_c$$

In U.S. Customary units:

$$F_x = 92D_c \quad M_x = 462D_c$$

$$F_y = 231D_c \quad M_y = 231D_c$$

$$F_z = 185D_c \quad M_z = 231D_c$$

where

F_x = horizontal component of F_c parallel to the compressor shaft, in Newtons (lb.),

F_y = vertical component of F_c , in Newtons (lb.),

F_z = horizontal component of F_c at right angles to be compressor shaft, in Newtons (lb.),

M_x = component of M_c around the horizontal axis, in Newton-meters (ft-lb.),

M_y = component of M_c around the vertical axis, in Newton-meters (ft-lb.),

M_z = component of M_c around the horizontal axis at right angles to the compressor shaft, in Newton-meters (ft-lb.).

c. These values of allowable forces and moments pertain to the turbo-expander structure only. They do not pertain to the forces and moments in the connecting pipes, flanges, and flange bolting, which should not exceed the allowable stress as defined by applicable codes and regulatory bodies.

Loads may be increased by mutual agreement between the purchaser and vendor; however, it is recommended that expected operating loads be minimized.

**ANNEX 4F
APPLICATION CONSIDERATIONS FOR
ACTIVE MAGNETIC BEARINGS
(INFORMATIVE)**

F.1 General

F.1.1 SCOPE

This specification describes the technical performance criteria for the purchase of active magnetic bearing systems for high-speed expander-compressors.

Note: Magnetic bearings can be used in expander-compressor systems (commonly known as turboexpanders) for many reasons, most notably to eliminate the possibility of oil contamination and fouling in the cryogenic process system, even if the turboexpander is severely damaged while in operation.

F.1.2 DEFINITION OF TERMS

F.1.2.1 A magnetic bearing is a device which supports the shaft of a rotating machine using magnetic forces, specifically without the use of lubricating oil.

F.1.2.2 An active magnetic bearing is magnetic bearing in which the magnetic forces are actively controlled by a control system. Most rotating equipment uses active magnetic bearings as opposed to “passive” magnetic bearings, which utilize permanent magnets and are not actively controlled.

F.1.2.3 A radial magnetic bearing supports the shaft in the radial, as opposed to axial, direction. It is typically composed of four quadrants per bearing.

F.1.2.4 A lamination stack is a series of thin, magnetically soft sheets of iron-based material stacked tightly together but separated by a thin, electrically insulating oxide layer. The purpose of the lamination stack is to reduce eddy current losses and heating in the magnetic bearing and rotor. Rotor lamination stacks are typically provided in conjunction with the radial bearing system, both for the magnetic bearing itself, and for certain types of rotor position sensors, such as inductive position sensors. Axial magnetic bearings typically do not utilize a rotor lamination stack, partly because there are smaller eddy currents developed (due to favorable pole orientation), and partly because of the mechanical difficulties involved in such a design, especially for high speed applications.

F.1.2.5 Class A amplifier configuration refers to a method of connecting the amplifiers in the magnetic bearing control system. The vast majority of rotating equipment with magnetic bearings utilizes a Class A amplifier configuration. In this configuration, a levitated rotor with no other forces acting on it would have both the upper and lower bearings loaded to about 50% of their capacity. If an external load is then applied (for example, gravity acting on the mass of the rotor), then the upper bearing would have its force increased and the lower bearing would have its force decreased so that the system remained in equilibrium and the rotor remained centered in the bearing. This method allows the bearing system to operate in a more linear portion of the material’s magnetization curve, thus enhancing control capability.

F.1.2.6 A quadrant is a segment of a radial magnetic bearing composed of one or more coils wired such that the magnetic force of the coils in the quadrant act in unison. Typically, two quadrants, located 180 degrees apart, make up one radial axis.

F.1.2.7 An axial magnetic bearing supports the shaft in the axial direction. It is typically constructed of two opposing bearings (to provide double acting response), each activated by one or more annular coils.

F.1.2.8 An axis denotes a specific location and direction in which the magnetic bearing can apply bi-directional forces. The typical expander-compressor will be supported by a five-axis active magnetic bearing system. These 5 are: 2 radial at the expander end, 2 radial at the compressor end, and 1 axial axis.

F.1.2.9 An auxiliary bearing system (also called “backup bearings,” “catcher bearings,” or “coastdown bearings”) serves three purposes:

1. Provides support for the rotor when power to the magnetic bearing system is off.
2. Helps to prevent damage to the rotor and stator in the event of an upset that momentarily exceeds the capacity of the magnetic bearings.
3. Allows the rotor to coastdown without damage to the rotor or stator in the event of a failure of the magnetic bearing system.

Auxiliary bearings are by design considered consumable, and thus their life depends on the operating history of the machine into which they are installed.

F.1.2.10 Levitation refers to activating the currents to the bearing such that the rotor is suspended within the magnetic bearing for the particular axis that is levitated. Levitation of the rotor usually refers to activating all axes simultaneously.

F.1.2.11 A delevitation occurs when the auxiliary bearing system is contacted while the rotor is in operation. This contact can be purely radial, purely axial, or a combination of the two. It can be the result of overload of the magnetic bearing system, or due to electrical de-activation of one or more axes in the system.

F.1.2.12 A landing surface or landing sleeve is the surface on the rotor which is meant to contact the auxiliary bearing surface during a delevitation.

F.1.2.13 Rotor position sensors provide the vibration data that would typically be provided by eddy current probes in oil lubricated machinery. These signals also provide the control electronics the information needed to correctly position the shaft within the bearing clearance.

F.1.2.14 Local electronics are any electrical components required by the magnetic bearing system that are not included

in the control system cabinet and are thus located on or near the machine skid.

F.1.2.15 A tracking filter provides a means of removing the 1 times unbalance forces from being acted upon by the control circuit. This prevents the amplifiers from responding to the forces. This allows the rotor to more nearly operate about its mass center, and can greatly reduce the unbalance force transmitted to the stator.

F.1.2.16 An automatic thrust equalizer is a system for reducing the overall thrust seen by the axial magnetic bearings due to process loads and pressures inside the machine. In practice, this system uses the axial bearing currents as an indicator of thrust load to control a valve which varies the injection and/or venting of gas in a cavity behind one of the impellers on the rotor, thus attempting to balance the axial current.

F.1.3 REFERENCED PUBLICATIONS

The editions of the following standards, codes, and specifications that are in effect at the time of publication of this specification shall, to the extent specified herein, form a part of this standard. The applicability of changes in standards, codes, and specifications that occur after the inquiry shall be mutually agreed upon by the purchaser and the vendor.

—EN 55011 Group 1, Class A

—EN 61000-6-2

F.2 Basic Design

F.2.1 The equipment (including auxiliaries) covered by this standard shall be designed and constructed for a minimum service life of 20 years and at least 5 years of uninterrupted operation.

F.2.2 The typical scope of supply:

1. Bearing and sensor rotor lamination stacks (two per shaft).
2. Radial magnetic bearing stator assemblies (two per machine).
3. Axial magnetic bearing stator assemblies (two per machine).
4. Radial and axial position sensors and any associated electronics.
5. Auxiliary bearings for radial and axial loads, including damping mechanism and cartridge-style assembly.
6. Speed probes (two per bearing cartridge).
7. Control cabinet (typically one per machine).
8. Documentation.

F.2.3 The vendor shall supply a “liquid proof” bearing and sensor design suitable for momentary exposure (up to several min.) with hydrocarbon liquids.

F.2.4 All components shall be suitable for operation, both during shop tuning and testing and under field conditions.

F.2.5 All leads (power, sensor, speed, and temperature) shall be identified at both the stator end and the connector end. Identification shall be durable in the intended environment and shall be able to withstand handling associated with installation and removal.

F.2.6 Electrical insulation of stator windings shall be Class H (180°C). Overall bearing assembly shall be rated to Class F (155°C).

F.2.7 Sufficient area must be provided on the rotor to turn the assembled shaft assembly on a balancing machine. The total indicated runout between the surface used for balancing and the surface used by the sensors to determine rotor position is not to exceed 5 microns (0.0002 in.).

F.2.8 The rotor landing surfaces or landing sleeves shall be either repairable or replaceable, without causing replacement of the entire rotor system.

F.3 Radial Magnetic Bearing System

F.3.1 The load capacity of the radial bearings should be designed with sufficient force capability to prevent contact between the rotor and any portion of the stator (including the auxiliary bearings) at all speeds from zero to maximum.

F.3.2 The unit shall be capable of running continuously from zero to trip speed with steady aerodynamic side loads at each impeller equivalent to 4% of the total torque produced by the expander-compressor at the planned normal operating point. The force derived from this torque is considered to act at the outer diameter of each wheel.

F.3.3 Two removable and replaceable temperature sensors shall be installed in each upper part of the radial bearing. One will be used for over temperature protection and the other as an installed spare.

F.3.4 The radial position sensors shall be located as close to the radial magnetic bearing as possible.

F.4 Axial Magnetic Bearing System

F.4.1 The load capacity of the axial magnetic bearing system shall be sized to permit operation without contacting the auxiliary bearings for all given operating conditions. If an automatic thrust equalizing control is used, the magnetic bearing shall be no less than 2 times the largest residual thrust expected using the automatic thrust equalizing system.

F.4.2 Two axial position sensors shall be provided. They shall be used together to provide linearized axial position signals, as well as rotor to stator differential expansion information.

F.4.3 Two removable and replaceable temperature sensors shall be installed in each axial bearing. One will be used for over temperature protection and the other as an installed spare.

F.5 Auxiliary Bearing System

F.5.1 Auxiliary bearings shall be provided, located at each shaft end outboard of the magnetic radial bearing and inboard of the shaft seal.

Note: Typical auxiliary bearings for a high speed expander-compressor utilize soft mounted angular contact ball bearings mounted in a face-to-face configuration. In many cases, ceramic balls are used with steel races. A dry film lubricant is typically employed to provide lubrication when the auxiliary bearings are forced into service. Other types of auxiliary bearings can and have been used successfully, depending on the application.

F.5.2 The auxiliary bearings shall be provided with a damping mechanism, if required, to prevent destructive whirl during coastdown. The damping system shall be provided by the vendor and shall be a proven design.

F.5.3 The bearings shall be provided with the vendor's recommended dry film lubricant. This lubricant shall be compatible with the intended environment (both shop testing and in the field) and shall not adversely affect adjacent components.

F.5.4 The radial and axial stiffness of the bearing assembly must be sufficient to withstand a sudden shock load equal to the full capacity of the magnetic bearing (plus kinetic energy), without allowing contact between any portion of the rotor and stator.

F.5.5 Replaceable rundown sleeves under the auxiliary bearings are desirable, but not required where design constraints prohibit their use.

F.5.6 The auxiliary bearing system shall be designed to survive at least two delevitations from maximum continuous speed to zero speed with the normal aerodynamic braking and nominal process induced thrust load (which should not be larger than 75% of the thrust bearing rated load capacity).

Note: It is recognized that rolling element bearings have not been designed with this application in mind and that only limited relations exist for prediction of their useful life under these conditions. Nevertheless, it is essential that the auxiliary bearing system is capable of surviving a minimum duty cycle prior to inspection and replacement is required.

F.5.7 The auxiliary bearing system shall be designed to survive at least ten momentary contacts caused by process upset conditions that exceed the capacity of the magnetic bearings. For these momentary contacts, it is assumed that the magnitude of the overload exceeds the magnetic bearing force

capacity by 25%, the duration is less than 0.5 sec., and that the rotor has not fully delevitated (i.e., the magnetic bearing system is sharing the load).

F.6 Monitoring and Control

F.6.1 GENERAL

F.6.1.1 The control system shall consist of an enclosure containing amplifiers, control electronics, and other equipment necessary for the operation and safety of all magnetic bearings. The control system shall provide alarm and shut-down protective logic for the magnetic bearings, auxiliary bearings, and control cabinet.

F.6.1.2 An electronic communications link shall be provided for connection to purchaser's control computer, if specified. All inputs and outputs from the control cabinet, and all alarms and trip status shall be available over the communications link in digital form.

F.6.1.3 The magnetic bearing control system shall have the capability of moving the rotor both radially and axially in order to check for wear on the auxiliary bearings. This check shall be possible with the expander-compressor in service but not running (i.e., disassembly shall not be required to perform this check).

F.6.1.4 The control system shall not emit or be receptive to EMF signals and shall comply with standards EN 55011 Group 1 Class A and EN 61000-6-2.

F.6.1.5 The amplifiers shall be configured for Class A operation, unless a different configuration is considered superior for a given application.

F.6.2 ENCLOSURE

F.6.2.1 Unless otherwise specified, the enclosure shall be designed for bottom entry wiring, and shall be suitable for the area classification and location specified.

F.6.2.2 Air cooling is normally used for amplifier cooling requirements. The control cabinet shall be provided with multiple cooling fans. Failure of a single fan shall not cause overtemperature shutdown to occur. If water cooling is used, provision must be made to prevent problems from condensation.

F.6.3 ROTOR POSITION SENSORS

F.6.3.1 Sensors shall be vendor's standard design with demonstrated operating experience.

F.6.3.2 Sensor components and assembly shall be compatible with the environment within the bearing housing.

F.6.4 LOCAL ELECTRONICS

F.6.4.1 The use of local electronics shall be minimized.

F.6.4.1.1 Local electronics, if required, shall be provided. Local electronics to be suitable for specified hazardous area and for specified ambient temperature and humidity range.

F.6.5 POWER INPUT FILTERS

F.6.5.1 Vendor shall provide EMF filters on control cabinet power supply, if necessary, to avoid contamination of input power by magnetic bearing power amplifiers.

F.6.6 MAN-MACHINE INTERFACE

F.6.6.1 Vendor's standard MMI shall be provided. English language shall be used.

F.6.7 UPS/BATTERY BACKUP SYSTEM

F.6.7.1 Vendor's standard UPS/battery backup system shall be provided if the customer's UPS system is not utilized. It shall allow a minimum of 5 min. of levitation upon loss of the normal electric power supply.

F.6.7.2 Vendor's monitoring system shall monitor the status of vendor supplied batteries. Alarm and shutdown signals shall be provided for low and low-low battery condition.

F.6.8 CABLING

F.6.8.1 The vendor shall specify cabling requirements for the bearing power and sensor connections. Any electrical or electronic components required to adjust for the installed length shall be included in the vendor's scope of supply.

Note: On systems where the cable distance between the expander-compressor and the control cabinet are long (100 m – 300 m, or 300 ft – 1000 ft), special consideration should be given to the electrical compensation and type of cable used to insure proper operation. In addition, long cable lengths are costly. For shop testing, where the cable length is almost always shorter than field cable lengths, electrical compensation is also necessary.

F.7 Shop Testing

F.7.1 All electronic components shall have a 24-hour burn-in prior to shipment.

F.7.2 The insulation resistance of assembled bearing power coils shall be greater than 50 megohms when tested with a 500 Volt DC megohmmeter.

F.7.3 The magnetic bearing control system shall be functionally tested prior to shipment.

F.7.4 Static load capacity tests shall be performed on all new bearing designs.

F.7.5 Static and dynamic test shall be performed using cable provided by the vendor. In general, this will not be the same cable as that used in the field. The vendor shall allow for any special tuning adjustments in his design.

F.7.6 The dynamic test (mechanical running test) at the vendor's facility shall constitute shop acceptance of the magnetic bearing system. The acceptance criteria is as follows:

The maximum allowable rotor movement relative to the center of the auxiliary bearing for any given axis of levitation is 0.3 times the minimum radial clearance in the auxiliary bearing in that axis. This movement can be the result of any or all of various components, such as overall shaft vibration, casing distortion, aerodynamic loading, etc. However, the combined total overall movement in any single axis, as measured by the shaft position sensors, must not exceed 0.3 times the minimum clearance to the auxiliary bearing in that axis. This criteria supersedes all other vibration acceptance criteria as described for oil bearing machines earlier in this specification.

Notes:

1. Magnetic bearings do not have a babbitted surface to fatigue (like highly loaded oil film bearings) when subjected to high vibration levels. In fact, transmitted forces in a magnetic bearing equipped machine are minimized by allowing the shaft to rotate about its inertial axis.
2. This criteria is somewhat like combining the AC and DC components from a typical eddy current probe used on oil lubricated machines. In effect, the magnetic bearing equipped rotor must operate near the center of the clearance space provided by the auxiliary bearing to avoid contact. If steady state forces or internal misalignment cause the rotor to shift from this centered position (i.e., the "DC" component), then less vibration (i.e., the "AC" component) can be tolerated.
3. Example: Assume the minimum radial clearance from the rotor to the auxiliary bearing is 250 microns (0.010 in.). 30% of this value is 75 microns (0.003 in.). This represents the maximum shaft movement allowed relative to the center of the auxiliary bearing clearance for this particular axis (radial or axial). Thus, if the shaft operates eccentrically from the center by 50 microns (0.002 in.) in this axis, then the maximum allowable overall vibration level allowed would be 25 microns (0.001 in.), zero to peak. Note that this value is for one axis only, and is not to be vectorially added to an orthogonal axis.

F.7.7 For new, unproven designs, a delevitation test shall be performed during shop testing to verify that the auxiliary bearings are acceptable for the intended duty. The delevitation tests shall constitute shop acceptance of the auxiliary bearing system. It shall be demonstrated that the auxiliary bearing system can meet the following requirements:

While operating the expander-compressor at the maximum continuous speed, with radial and axial loads no less than those expected during normal operation of the equipment in the field, all axes shall be delevitated for a 3-sec. period, then re-levitated. The machine will then be stopped and internal clearances will be checked electrically. If these clearances are still acceptable, a second delevitation test will be performed as above. Following the second test, the expander-compressor will be disassembled and inspected. Any parts showing unac-

ceptable damage shall be replaced. However, acceptance of the shop delevitation test is based on successfully completing the second delevitation without damaging parts of the magnetic bearing system other than the auxiliary bearing mechanism. Damage to the auxiliary bearings or landing surfaces does not constitute failure of the delevitation test.

Notes:

1. Auxiliary bearings and landing surfaces are considered backup systems and are consumable as a result of use. While it is possible that these parts are suitable for shipment with the equipment after final testing, replacing these parts does not constitute a failure of the test, nor require re-running of the test due to the replacement of the parts.
2. In actual field operation, the braking torque is substantially higher than during the shop test, thus the rotor will slow down much more rapidly in the field following a trip signal. The shop delevitation test is not meant to duplicate this condition, but rather to provide a uniform method of testing which will prove the system's ability to accelerate to full speed almost instantly and support the rotor without damaging the magnetic bearing. It has been found from calculation that 3 sec. at maximum continuous speed will approximately match or exceed the maximum

temperature that the auxiliary bearings will reach when subjected to the actual field braking torque conditions.

F.8 Field Test

F.8.1 Field testing shall consist of commissioning the unit for operation under the normal specified operating conditions. Under these conditions, the maximum allowable rotor movement shall comply with F.7.6, except that the maximum allowable rotor movement for field operation is 0.4 times the minimum radial clearance, instead of 0.3 as required for shop testing.

Note: Although there are many advantages of magnetic bearings when compared to oil lubricated bearings, the magnetic bearings are considerably weaker in terms of loading per unit area. Because field power levels are substantially higher than most shop tests, and fewer variables are controlled, it is reasonable to expect that field rotor motions will be larger than those obtained during controlled, low-power shop tests.

F.8.2 In the event that field rotor motion exceeds 40% of the auxiliary bearing radial clearance as described above, the purchaser and vendor shall review the data and mutually agree what, if any, action is necessary to correct the situation.

ANNEX 4G LUBRICATION AND SEALING SYSTEMS

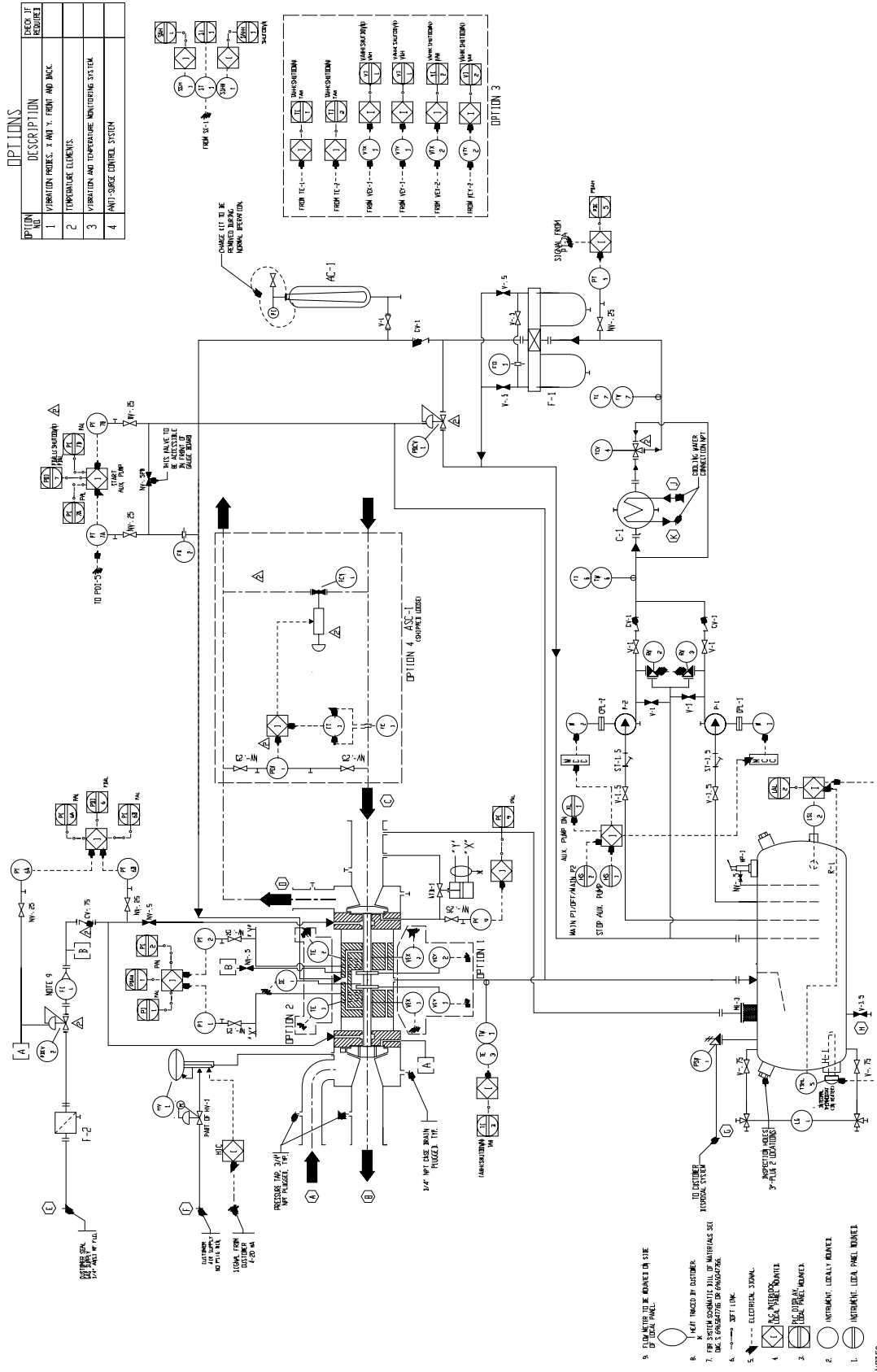
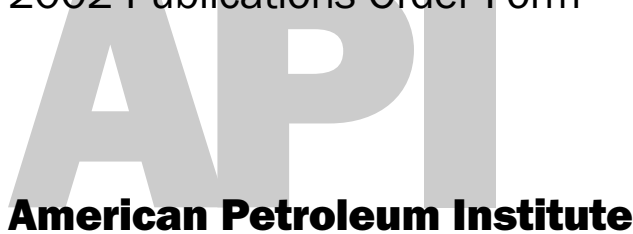

Figure 4.G-1—Typical Lubrication System for an Expander-compressor

2002 Publications Order Form



Available through Global Engineering Documents.

Effective January 1, 2002.

Phone Orders: 1-800-854-7179 (Toll-free in the U.S. and Canada)
303-397-7956 (Local and International)
Fax Orders: 303-397-2740
Online Orders: www.global.ihs.com

Date: _____

API Member (Check if Yes)

Invoice To (Check here if same as "Ship To")

Name: _____
 Title: _____
 Company: _____
 Department: _____
 Address: _____

 City: _____ State/Province: _____
 Zip/Postal Code: _____ Country: _____
 Telephone: _____
 Fax: _____
 E-Mail: _____

Ship To (UPS will not deliver to a P.O. Box)

Name: _____
 Title: _____
 Company: _____
 Department: _____
 Address: _____

 City: _____ State/Province: _____
 Zip/Postal Code: _____ Country: _____
 Telephone: _____
 Fax: _____
 E-Mail: _____

Quantity	Product Number	Title	SO★	Unit Price	Total
	C61008	Std 610, Centrifugal Pumps for Petroleum, Heavy Duty Chemical and Gas Industry Services		\$ 136.00	
	C61404	Std 614, Lubrication, Shaft-sealing, and Control-oil Systems and Auxiliaries for Petroleum, Chemical and Gas Industry Services		\$ 136.00	
	C61804	Std 618, Reciprocating Compressors for Petroleum, Chemical and Gas Industry Services		\$ 131.00	
	C61903	Std 619, Rotary-Type Positive Displacement Compressors for Petroleum, Chemical and Gas Industry Services		\$ 131.00	
	C67004	Std 670, Vibration, Axial-position, and Bearing-temperature Monitoring Systems		\$ 131.00	
	C68401	Publ 684, Tutorial on the API Standard Paragraphs Covering Rotor Dynamics and Balance		\$ 120.00	
	C68601	RP 686, Machinery Installation and Installation Design		\$ 120.00	
	C68701	RP 687, Rotor Repair		\$ 201.00	

Payment Enclosed **P.O. No.** (Enclose Copy) _____

Charge My Global Account No. _____

VISA **MasterCard** **American Express** **Diners Club** **Discover**

Credit Card No.: _____

Print Name (As It Appears on Card): _____

Expiration Date: _____

Signature: _____

Subtotal	
Applicable Sales Tax (see below)	
Rush Shipping Fee (see below)	
Shipping and Handling (see below)	
Total (in U.S. Dollars)	

★ *To be placed on Standing Order for future editions of this publication, place a check mark in the SO column and sign here:*

Pricing and availability subject to change without notice.

Mail Orders – Payment by check or money order in U.S. dollars is required except for established accounts. State and local taxes, \$10 processing fee*, and 5% shipping must be added. Send mail orders to: **API Publications, Global Engineering Documents, 15 Inverness Way East, M/S C303B, Englewood, CO 80112-5776, USA.**

Purchase Orders – Purchase orders are accepted from established accounts. Invoice will include actual freight cost, a \$10 processing fee*, plus state and local taxes.

Telephone Orders – If ordering by telephone, a \$10 processing fee* and actual freight costs will be added to the order.

Sales Tax – All U.S. purchases must include applicable state and local sales tax. Customers claiming tax-exempt status must provide Global with a copy of their exemption certificate.

Shipping (U.S. Orders) – Orders shipped within the U.S. are sent via traceable means. Most orders are shipped the same day. Subscription updates are sent by First-Class Mail. Other options, including next-day service, air service, and fax transmission are available at additional cost. Call 1-800-854-7179 for more information.

Shipping (International Orders) – Standard international shipping is by air express courier service. Subscription updates are sent by World Mail. Normal delivery is 3-4 days from shipping date.

Rush Shipping Fee – Next Day Delivery orders charge is \$20 in addition to the carrier charges. Next Day Delivery orders must be placed by 2:00 p.m. MST to ensure overnight delivery.

Returns – All returns must be pre-approved by calling Global's Customer Service Department at 1-800-624-3974 for information and assistance. There may be a 15% restocking fee. Special order items, electronic documents, and age-dated materials are non-returnable.

***Minimum Order** – There is a \$50 minimum for all orders containing hardcopy documents. The \$50 minimum applies to the order subtotal including the \$10 processing fee, excluding any applicable taxes and freight charges. If the total cost of the documents on the order plus the \$10 processing fee is less than \$50, the processing fee will be increased to bring the order amount up to the \$50 minimum. This processing fee will be applied before any applicable deposit account, quantity or member discounts have been applied. There is no minimum for orders containing only electronically delivered documents.

There's more where this came from.

The American Petroleum Institute provides additional resources and programs to the oil and natural gas industry which are based on API Standards. For more information, contact:

- Monogram Licensing Program Phone: 202-962-4791
Fax: 202-682-8070
- American Petroleum Institute Quality Registrar (APIQR) Phone: 202-962-4791
Fax: 202-682-8070
- API Spec Q1 Registration Phone: 202-962-4791
Fax: 202-682-8070
- Perforator System Registration Phone: 202-962-4791
Fax: 202-682-8070
- Inspector Certification Programs Phone: 202-682-8161
Fax: 202-962-4739
- Engine Oil Licensing and Certification System (EOLCS) Phone: 202-682-8233
Fax: 202-962-4739
- Training/Workshops Phone: 202-682-8490
Fax: 202-962-4797

Check out the API Publications, Programs, and Services Catalog online at www.api.org.



Helping You Get The Job Done Right.SM

01.01.02

.....

Additional copies are available through Global Engineering Documents at (800) 854-7179 or (303) 397-7956

Information about API Publications, Programs and Services is available on the World Wide Web at: <http://www.api.org>



1220 L Street, Northwest
Washington, D.C. 20005-4070
202-682-8000

Product No. C61707