



Helium Operators Familiarization Program Aluminium Plate and Fin Exchanger

Dec 2012 | Vincent HELOIN



HX - Stack

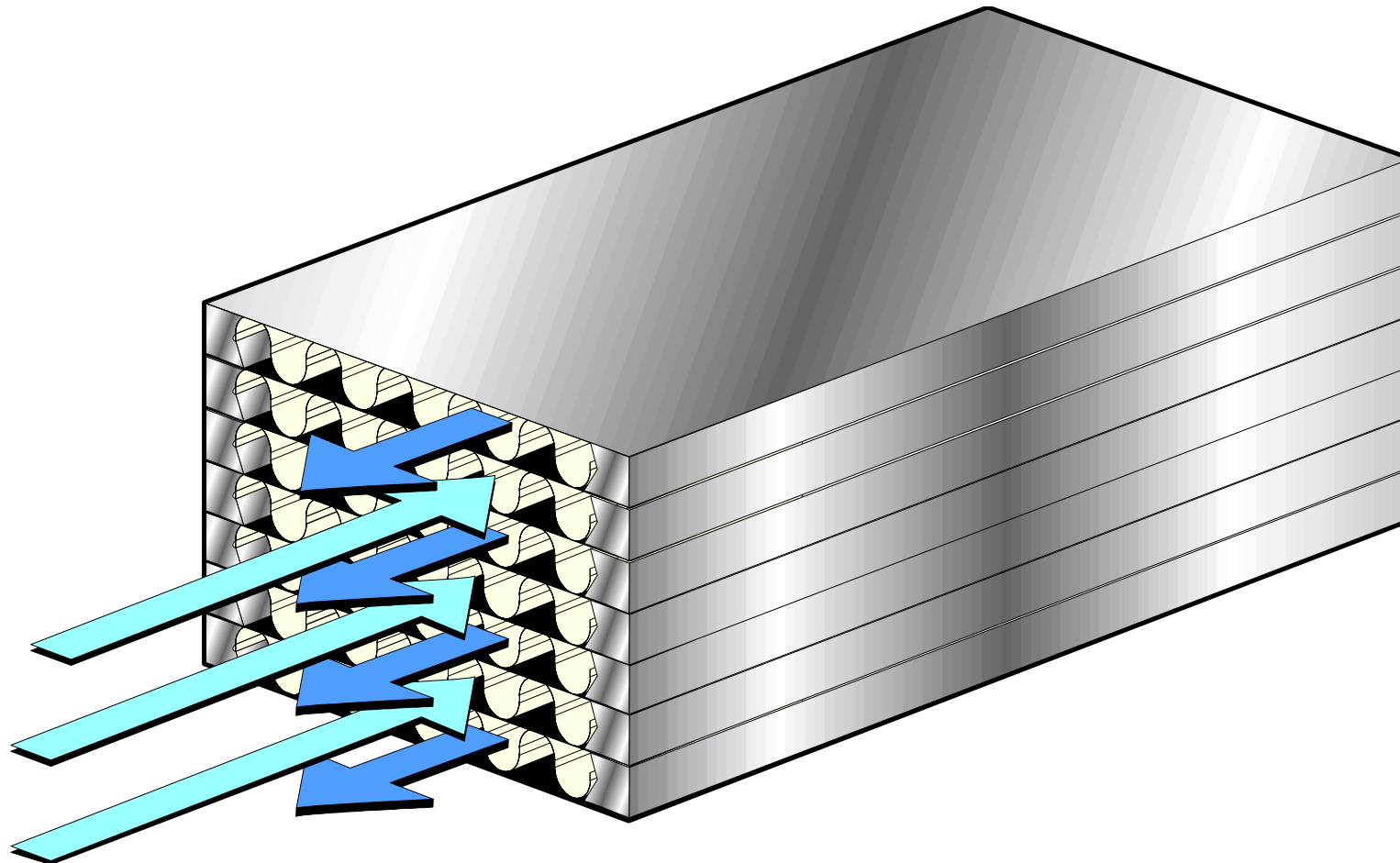

HX - a Layer

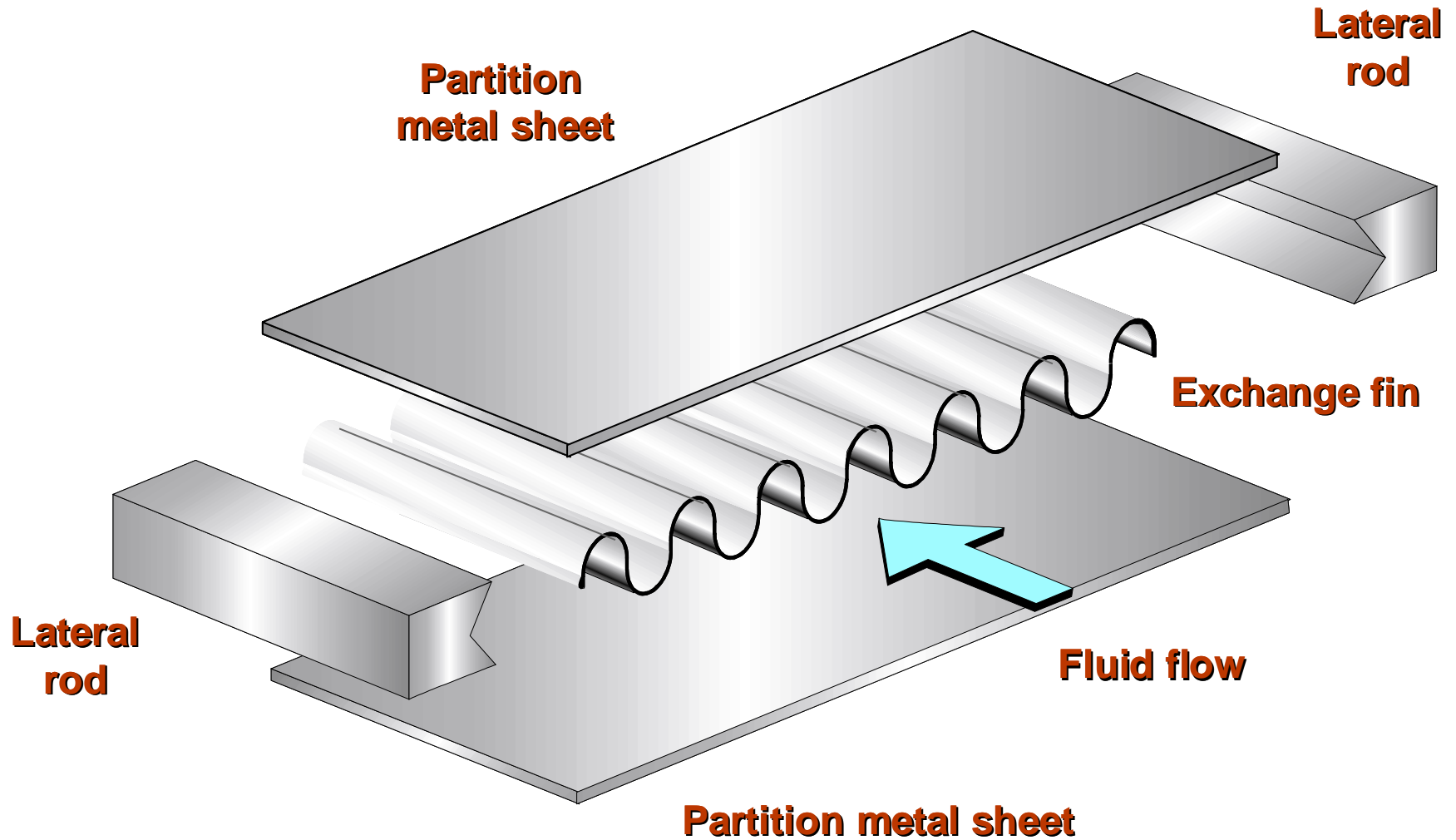

THE FINS



PLAIN

A sheet of metal corrugated with fins at right angles to the plate

Distribution zones

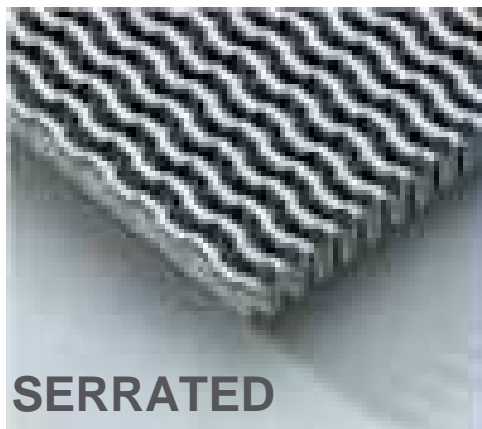

SERRATED

This corrugation is constructed by making cuts in the fin and displacing half way between the preceding

Gas

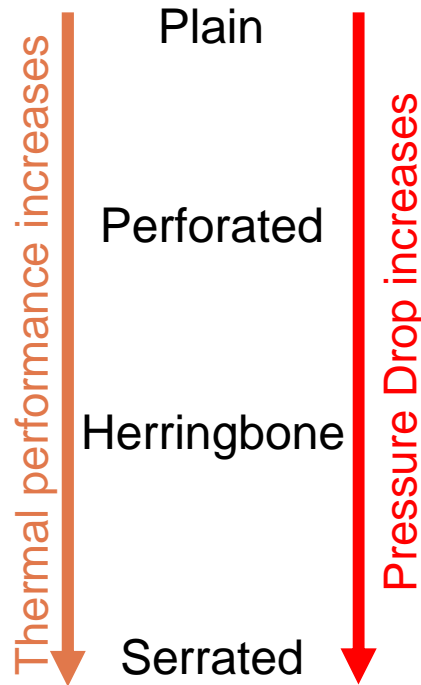

PERFORATED

A plain corrugation constructed from perforated material

Boiling streams



HERRINGBONE

Made by displacing the fins sideway to produce a zig-zag effect

Condensation or liquid

THE FINS - Manufacturing



FINS

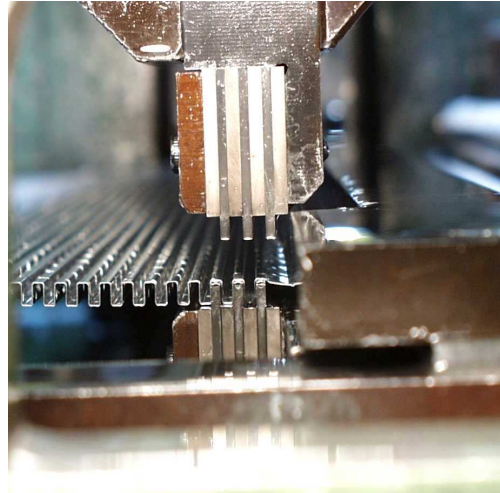

FINS



Plates Cutting



Plates Cutting



Stacking

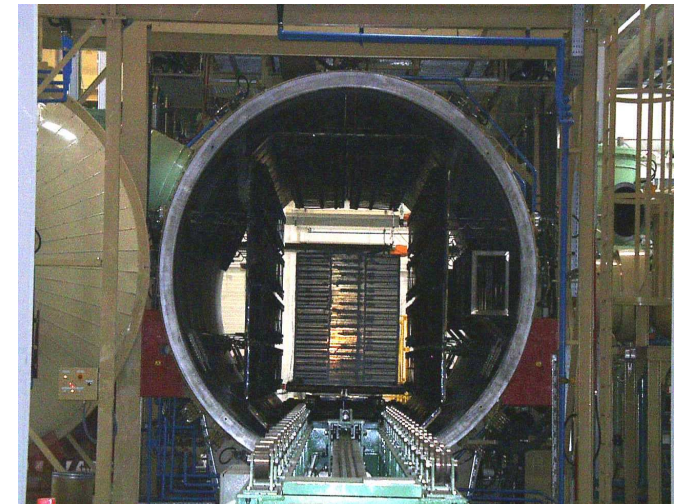

Brazing Furnace

Brazing Process

The parting sheets are covered with a brazing alloy

The core is inserted into a vacuum furnace at 600°C .

All metal contact points, braze together to form a compact block.

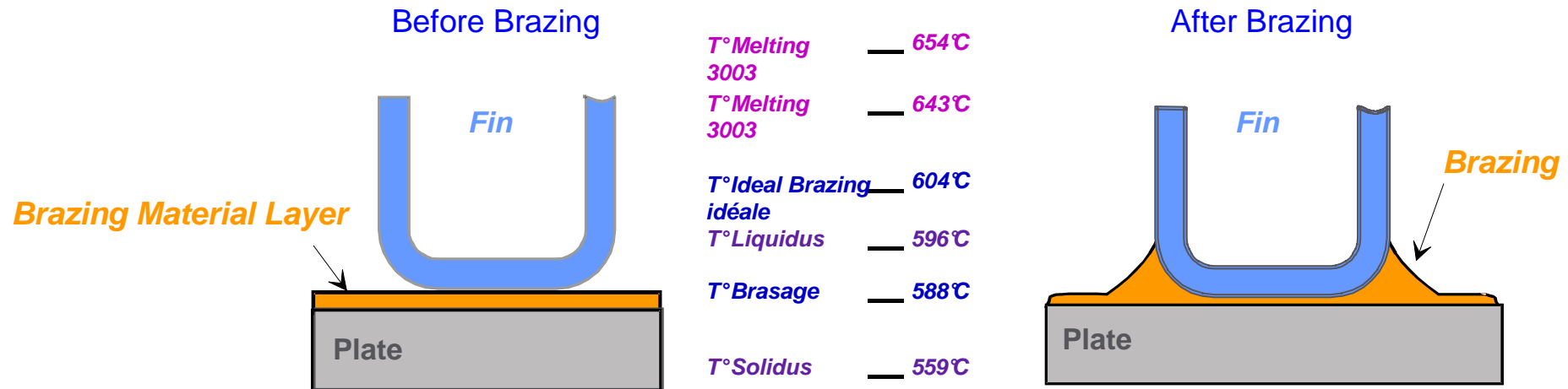
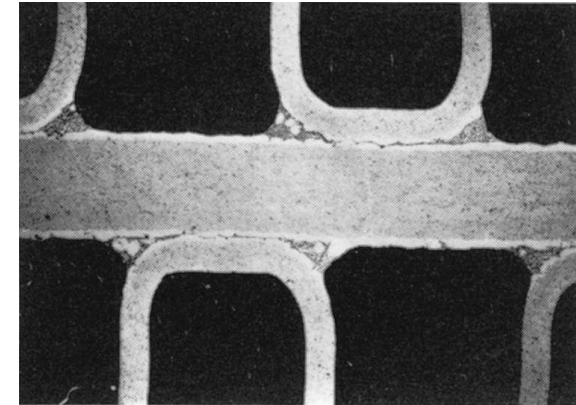

The process is monitored with thermocouples located inside the core to ensure even temperature distribution and brazing.

Remarks on Compact Heat Exchanger

Compact heat exchanger has up to 2000 m²/m³ (Shell and Tubes ~500m²/m³)

Increasing number of Fins Per Inch (FPI), increases the thermal performance

Increasing layer height reduces the pressure drop

Increasing fin thickness increases the pressure drop and enhances performance

Post Brazing Manufacturing Process

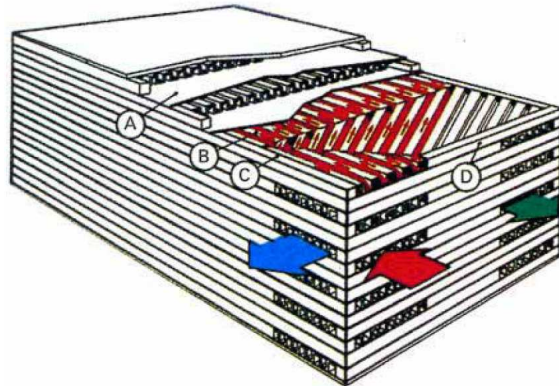

A : Separation Plate
 B : Exchange Surface
 C : Side bar
 D : End bar

Post Brazing Operations

- Welding of headers
- Hydraulic or Pneumatic Strength Test
- Helium Leak Testing (Internal and External)
- Welding of aluminium to stainless steel transition joints

Transition Joint

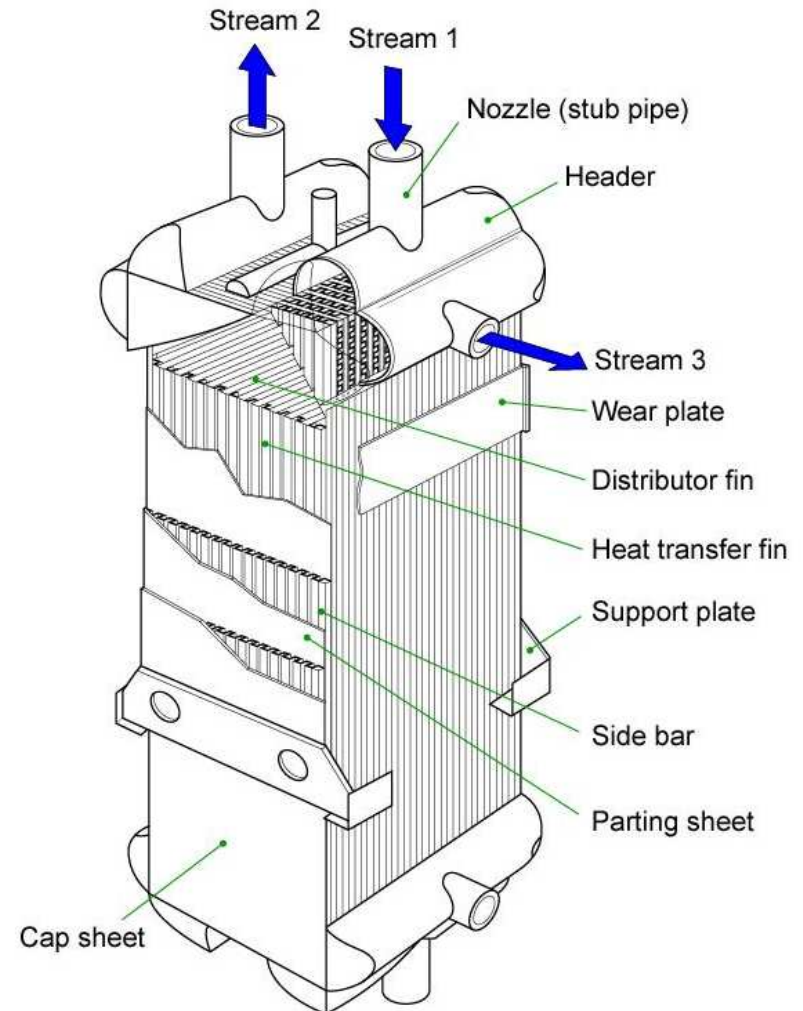
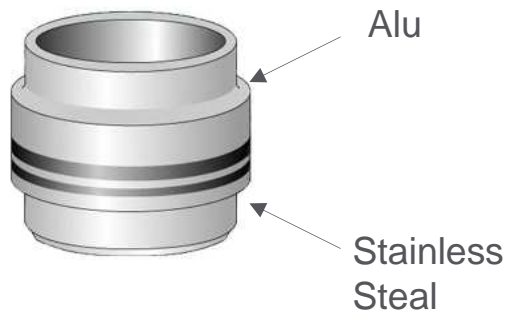

The Heat Exchangers Of The Liquefier

Qatar II Heat Exchanger (E01 / E02)



Important Rules

WARNING: FOLLOW ALPEMA REQUIREMENTS!

Cool-Down Rate: **< 2K / Minute**
Adjacent Flow Temperature Difference: **< 50 K**

Alarms have been implemented based on TDI (Temperature Difference). (No Trip)

It is the operator Responsibility to make sure that this TDI remains within acceptable values at all time.

Take care of these parameters during Cool Down !